

# Inhoudsopgave

Achteras Aandrijving .....	100
Achteras Behuizing .....	76
Brandstof Tank .....	34
Bumper & Motorkapsluiting .....	36
Dashbord .....	58
Diff Slot .....	104
Driepunt .....	164
Eindvertraging Wiel .....	102
Elecktrisch .....	120
Gas Kabels .....	16
Hydrauliek .....	126
Hydrauliek Hef .....	138
Hydrauliek PTO - Dif. Slot .....	134
Hydrauliek Stuur .....	130
Hydrauliek Ventielen .....	136
Knikstuk .....	72
Koppeling .....	80
Koppeling Pedaal & Aansturing .....	84
Luchtfiler .....	26
Motor .....	4
Motorkap .....	38
Oliekoeler .....	128
P.T.O. .....	106
P.T.O. Schakeling .....	112
Radiator & Slangen .....	18
Rem Pedaal .....	116
Remmen .....	114
Rolbeugel .....	42
Schakelpoken & Gaffels .....	96
Schakelpook & Zitting Montage .....	62
Spatschermen Achter .....	50
Spatschermen Voor .....	44
Stickers .....	54
Tandwielen .....	88
Treepanken & Kappen .....	46
Trekhaak .....	168
Vooras Aandrijving .....	78
Vooras Behuizing .....	70
Wielen & Banden .....	174
Zittingen .....	66
Parts Index .....	178

<b>Code</b>	<b>Description</b>	<b>Notes</b>
A.01.01_1_48842	ENGINE	Engine: 75 CV
A.01.02_1_45599	ENGINE	Engine: 85 CV
A.01.03_1_45644	ENGINE	Engine: 95 CV
A.02.02_0_42523	ENGINE CONTROLS	
A.03.01_0_45689	COOLER	Engine: 75 CV
A.03.02_0_45727	COOLER	Engine: 85 CV, 95 CV
A.04.01_0_45765	AIR FILTER	Engine: 75 CV
A.04.02_0_45780	AIR FILTER WITH EXTERNAL AIR INTAKE	Engine: 75 CV
A.04.03_0_45796	AIR FILTER	Engine: 85 CV, 95 CV
A.04.04_0_45812	AIR FILTER WITH EXTERNAL AIR INTAKE	Engine: 85 CV, 95 CV
A.05.02_0_45864	FUEL TANK	
B.01.01_0_47067	FRONT SUPPORT	
B.02.01_1_47161	BONNET	
B.03.03_0_50588	FRONT MUDGUARDS	
B.03.04_0_50621	FRONT MUDGUARDS (VERSION WITH CAB)	
B.04.07_0_40076	BOARDS	
B.05.03_0_50689	REAR MUDGUARDS	
B.05.04_0_50716	REAR MUDGUARDS (VERSION WITH CAB)	
B.07.02_0_42592	PLATES AND STICKERS	
B.08.02_0_38771	DASHBOARD	
B.11.01_0_38871	SEAT SUPPORT / GEAR LEVERS COVER	
B.12.03_0_46827	SEAT (STANDARD)	
B.12.04_0_51054	SEAT (KAB)	
C.01.02_0_39031	FRONT AXLE	
C.02.04_1_39212	CENTRAL SECTION	
C.03.02_0_39268	REAR AXLE	
D.01.02_0_40152	FRONT TRANSMISSION	
D.02.02_0_39318	CLUTCH FRONT SHAFT/ TRANSMISSION CLUTCH	
D.03.02_1_39804	CLUTCH CONTROLS	
D.04.01_1_42845	INPUT SHAFT / RANGES MAIN SHAFT / GEARS	Version: RS-M, RS-R, AR-M, AR-R
D.05.01_1_42883	GEARS MAIN SHAFT / GEARS	Version: RS-M, RS-R, AR-M, AR-R
D.06.01_1_42932	GEARS TRANSMISSION SHAFT / GEARS	Version: RS-M, RS-R, AR-M, AR-R
D.07.02_1_39700	GEARBOX CONTROLS	
D.09.02_0_39867	REAR TRANSMISSION	

**Thor 75–85-95 AR reversible**

<b>Code</b>	<b>Description</b>	<b>Notes</b>
D.10.01_0_39887	EPYCLIC REDUCTION GEARS	
D.11.01_0_40184	DIFFERENTIAL LOCK	
D.12.01_1_40279	POWER TAKE-OFF	
D.13.01_0_40355	POWER TAKE-OFF CONTROLS	
D.14.01_0_40378	BRAKES	
D.15.04_0_40488	BRAKES CONTROLS	
E.01.01_0_42630	FRONT ELECTRICAL SYSTEM	
E.02.01_0_46767	ENGINE ELECTRIC SYSTEM	
E.03.02_0_42668	REAR ELECTRICAL SYSTEM	
F.01.03_0_51164	HYDR. SYSTEM DOUBLE OIL SUCTION	
F.02.01_0_51232	HYDR. SYSTEM : HEAT EXCHANGER	
F.03.04_1_40827	STEERING HYDR. SYSTEM	
F.04.01_0_46735	PTO /DIFFERENTIAL LOCK HYDR. SYSTEM	
I.01.01_0_40883	HYDR. CONTROL VALVES: AVAILABLE PARTS	
L.01.01_0_40903	RAISE/LOWER LIFT	
L.02.02_0_40987	FREE DISCHARGE CONTROL VALVES VERSION	
L.02.05_0_41145	CONTROL VALVES WITHOUT FREE DISCHARGE VERSION	
M.01.01_0_41199	POSITION AND DRAFT CONTROL LIFT	
M.02.03_0_41409	FREE DISCHARGE CONTROL VALVES VERSION	
M.02.04_0_41480	CONTROL VALVES WITHOUT FREE DISCHARGE VERSION	
T.02.01_0_41647	IMPLEMENTS ATTACHMENT - STANDARD	
T.02.02_0_41675	IMPLEMENTS ATTACHMENT - ADJUSTABLE ARMS WITH QUICK HITCHES	
T.03.01_0_41710	PULL HOOK - STANDARD	
T.03.02_0_41719	POOL HOOK "EEC" APPROVED	
T.03.03_0_42459	SLIDER FRAME WITH EEC HOM. TOW HOOK	
W.01.03_0_44163	WHEELS AND TYRES (TABLE 1/2)	
W.01.04_0_45316	WHEELS AND TYRES (TABLE 2/2)	

**VM MOTORI**

MOTORE 4 CILINDRI - "13 C"  
 4 CYLINDERS ENGINE - "13 C"  
 MOTEUR 4 CYLINDRES - "13 C"  
 4 ZYLINDER MOTOR - "13 C"  
 MOTOR 4 CILINDROS - "13 C"

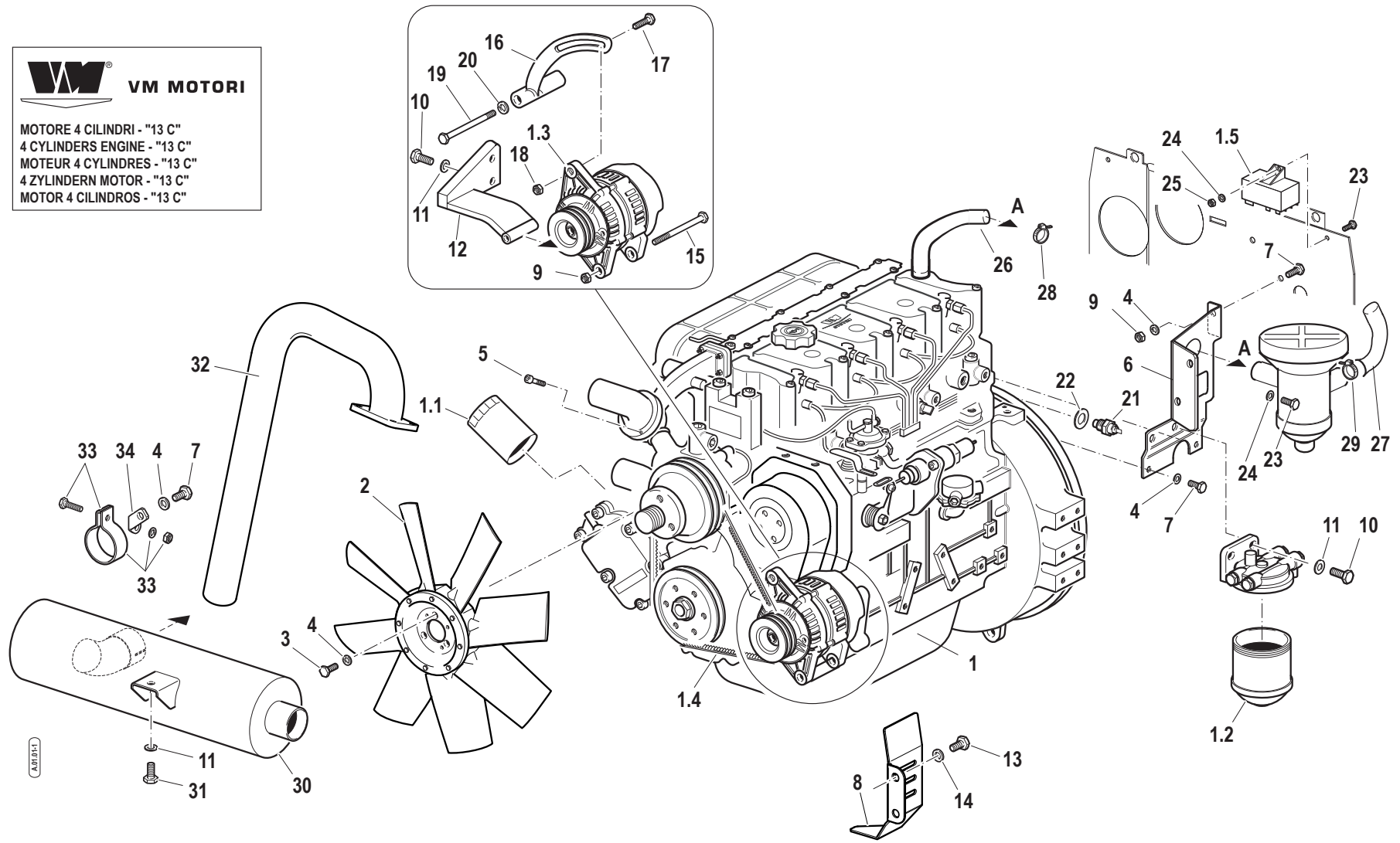



Pos.	Code	Q.ty	Description	Notes
1	41U50000	1	MOT.VM D754E2.21A 47KW 13C/4	
1.1	58171199	1	OIL FILTER CARTRIDGE	
1.2	58171200	1	FUEL FILTER CARTRIDGE	
1.3	59900344	1	ALTERNATOR	
1.4	59900766	1	BELT	
1.5	59900345	1	CENTRAL PROCESSING UNIT	
2	57376726	1	FAN	
3	31112150	3	SCREW TE M8X20 UNI 5739 8G	
4	F0843643060	7	WASHER 8	
5	F0862479035	1	SCREW	
6	59079167	1	RETAINER	
7	31111151	4	SCREW TE M8X16 UNI 5739 8G	
8	56177979	1	SHIELD	
9	31211080	2	NUT M8	
10	31112219	5	SCREW TE M10X25 UNI 5739	
11	F0843755000	6	WASHER 10	
12	59077318	1	SUPPORT	
13	31112082	2	SCREW TE M6X12 UNI 5739 8G	
14	31411064	2	WASHER 6,4x12,5	
15	31112174	1	SCREW TE M8X110 UNI 5737 8.8	
16	59076688	1	ROD	
17	31112153	1	SCREW TE M8X35 UNI 5739 8G	
18	31421083	1	WASHER	
19	F0864335020	1	SCREW M14X120 UNI 5737	
20	31421251	1	WASHER	
21	58175773	1	ELECTRONICAL THERMOMETER	
22	F0844030070	1	COPPER WASHER 16,0x22/1,5	
23	31112090	2	SCREW TE M6X16 UNI 5739 8G	
24	F0843570000	2	WASHER 6	
25	31211060	2	HEXAGONAL NUT M8	
26	55176744	1	PIPE	
27	58177400	1	OIL PIPE	
28	F0817500400	3	CLAMP 024,1-706R	
29	F0817500200	1	CLAMP 015,7-706R	

SERIAL

**ENGINE**  
Engine: 75 CV

CODE REV

**A.01.01\_1\_48842**

**VM MOTORI**

MOTORE 4 CILINDRI - "13 C"  
 4 CYLINDERS ENGINE - "13 C"  
 MOTEUR 4 CYLINDRES - "13 C"  
 4 ZYLINDER MOTOR - "13 C"  
 MOTOR 4 CILINDROS - "13 C"

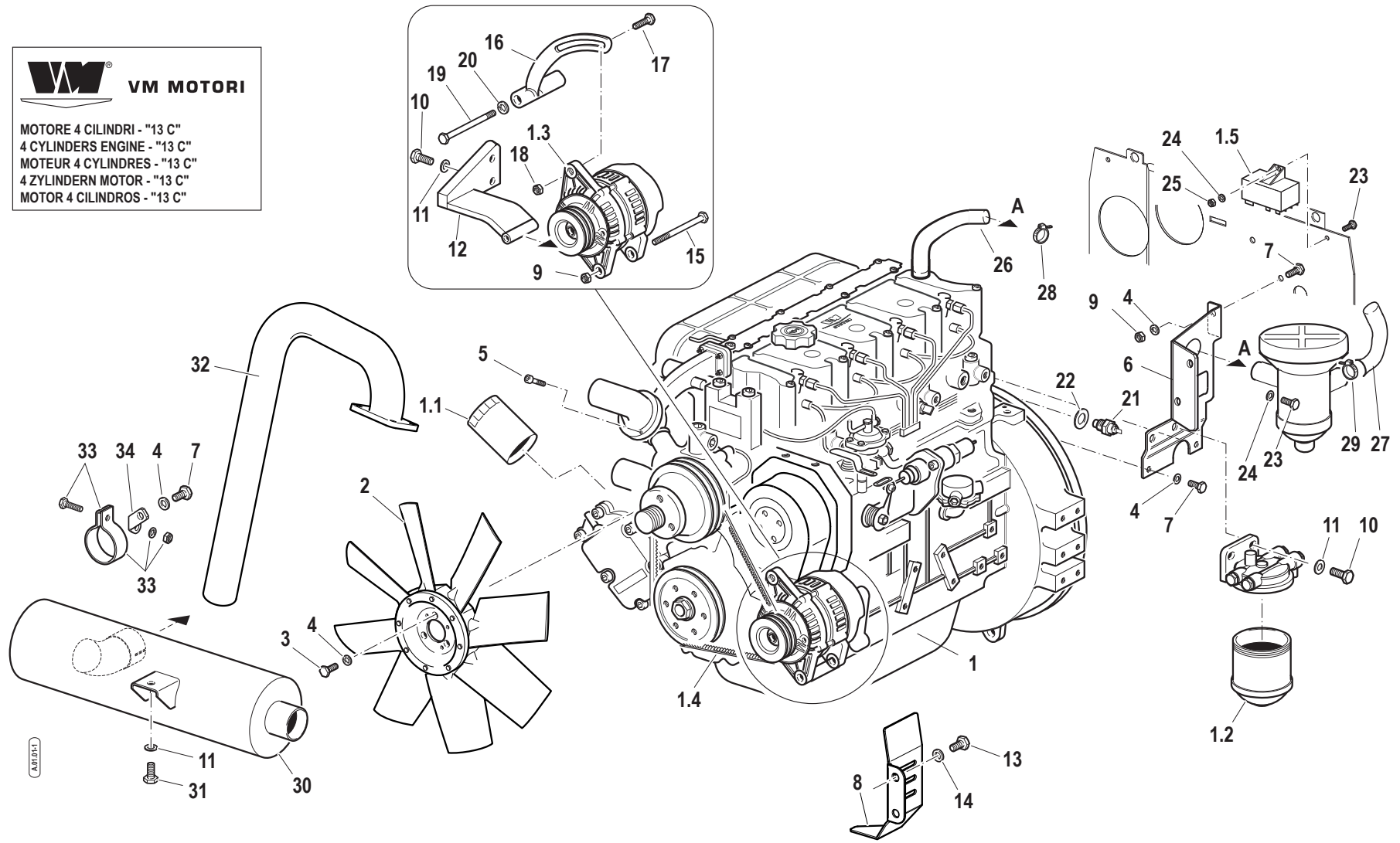

<b>Pos.</b>	<b>Code</b>	<b>Q.ty</b>	<b>Description</b>	<b>Notes</b>
30	58176618	1	EXHAUST SILENCER	
31	31112210	1	SCREW TE M10X20 UNI 5739	
32	59076620	1	EXHAUST	
33	58175121	1	COLLAR	
34	56177183	1	REINFORCED STRAP	

---

SERIAL

**ENGINE**  
Engine: 75 CV

CODE REV

**A.01.01\_1\_48842**



Pos.	Code	Q.ty	Description	Notes
1	41U60000	1	MOT.VM D704TE2.21A 60KW 77B/4	
1.1	58171199	1	OIL FILTER CARTRIDGE	
1.2	58171200	1	FUEL FILTER CARTRIDGE	
1.3	59900344	1	ALTERNATOR	
1.4	59900766	1	BELT	
1.5	59900345	1	CENTRAL PROCESSING UNIT	
2	58178646	1	FAN	
3	F0862694000	3	SCREW M8X170 UNI 5737	
4	F0843643060	7	WASHER 8	
5	F0862479035	1	SCREW	
6	59079167	1	RETAINER	
7	31111151	4	SCREW TE M8X16 UNI 5739 8G	
8	56177979	1	SHIELD	
9	31211080	2	NUT M8	
10	31112219	5	SCREW TE M10X25 UNI 5739	
11	F0843755000	6	WASHER 10	
12	59077318	1	SUPPORT	
13	31112082	2	SCREW TE M6X12 UNI 5739 8G	
14	31411064	2	WASHER 6,4x12,5	
15	31112174	1	SCREW TE M8X110 UNI 5737 8.8	
16	59076688	1	ROD	
17	31112153	1	SCREW TE M8X35 UNI 5739 8G	
18	31421083	1	WASHER	
19	F0864335020	1	SCREW M14X120 UNI 5737	
20	31421251	1	WASHER	
21	58175773	1	ELECTRONICAL THERMOMETER	
22	F0844030070	1	COPPER WASHER 16,0x22/1,5	
23	31112090	2	SCREW TE M6X16 UNI 5739 8G	
24	F0843570000	2	WASHER 6	
25	31211060	2	HEXAGONAL NUT M8	
26	55176744	1	PIPE	
27	58177400	1	OIL PIPE	
28	F0817500400	3	CLAMP 024,1-706R	
29	F0817500200	1	CLAMP 015,7-706R	

SERIAL

**ENGINE**  
Engine: 85 CV

CODE REV

**A.01.02\_1\_45599**

**VM MOTORI**

MOTORE 4 CILINDRI - "77 B"  
 4 CYLINDERS ENGINE - "77 B"  
 MOTEUR 4 CYLINDRES - "77 B"  
 4 ZYLINDER MOTOR - "77 B"  
 MOTOR 4 CILINDROS - "77 B"

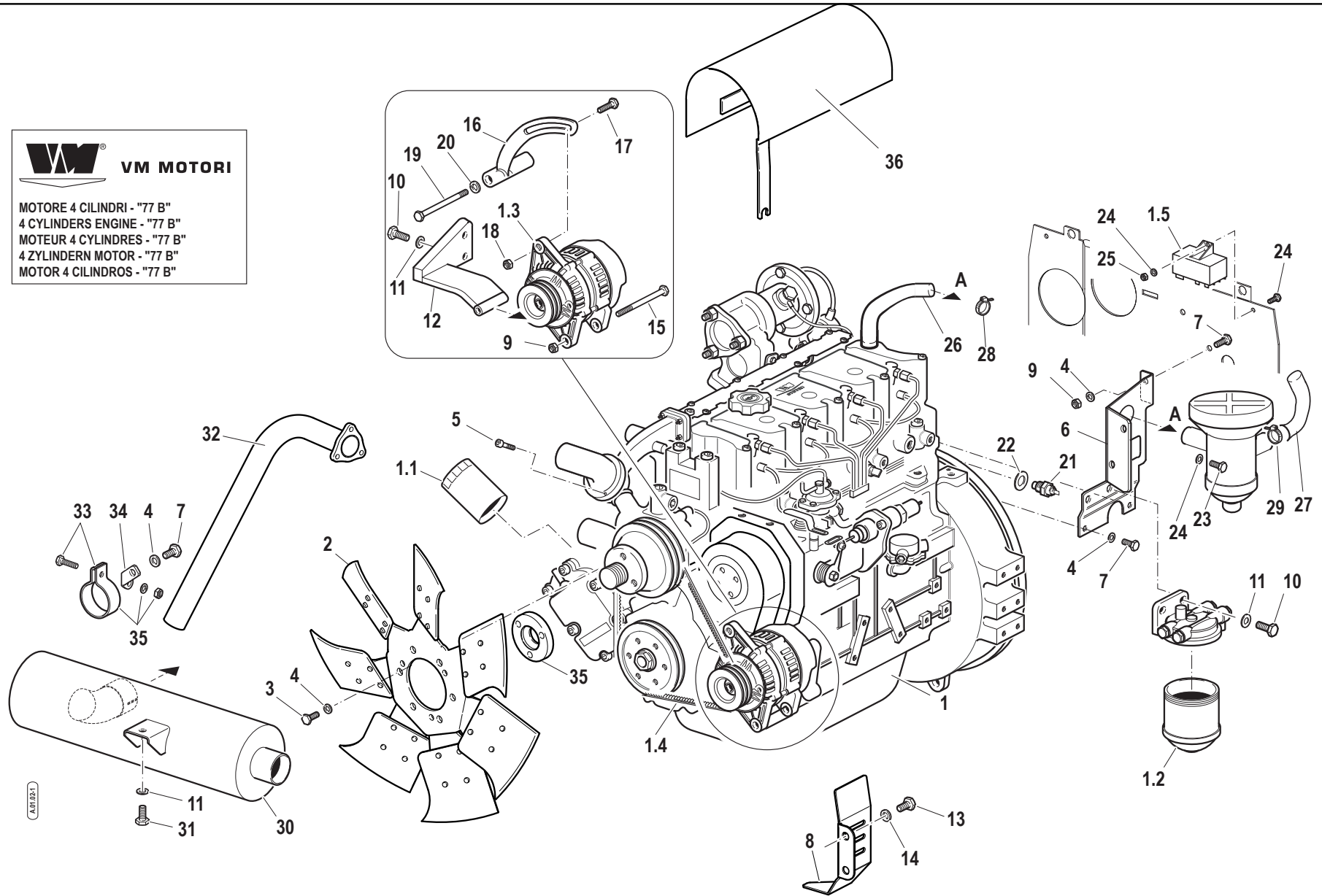

Pos.	Code	Q.ty	Description	Notes
30	58176618	1	EXHAUST SILENCER	
31	31112210	1	SCREW TE M10X20 UNI 5739	
32	59076619	1	EXHAUST	
33	58175121	1	COLLAR	
34	56177183	1	REINFORCED STRAP	
35	56178649	1	SPACER	
36	59076682	1	GUARD	

---

SERIAL

**ENGINE**  
Engine: 85 CV

CODE REV

**A.01.02\_1\_45599**

**VM MOTORI**

MOTORE 4 CILINDRI - "33 C"  
 4 CYLINDERS ENGINE - "33 C"  
 MOTEUR 4 CYLINDRES - "33 C"  
 4 ZYLINDER MOTOR - "33 C"  
 MOTOR 4 CILINDROS - "33 C"

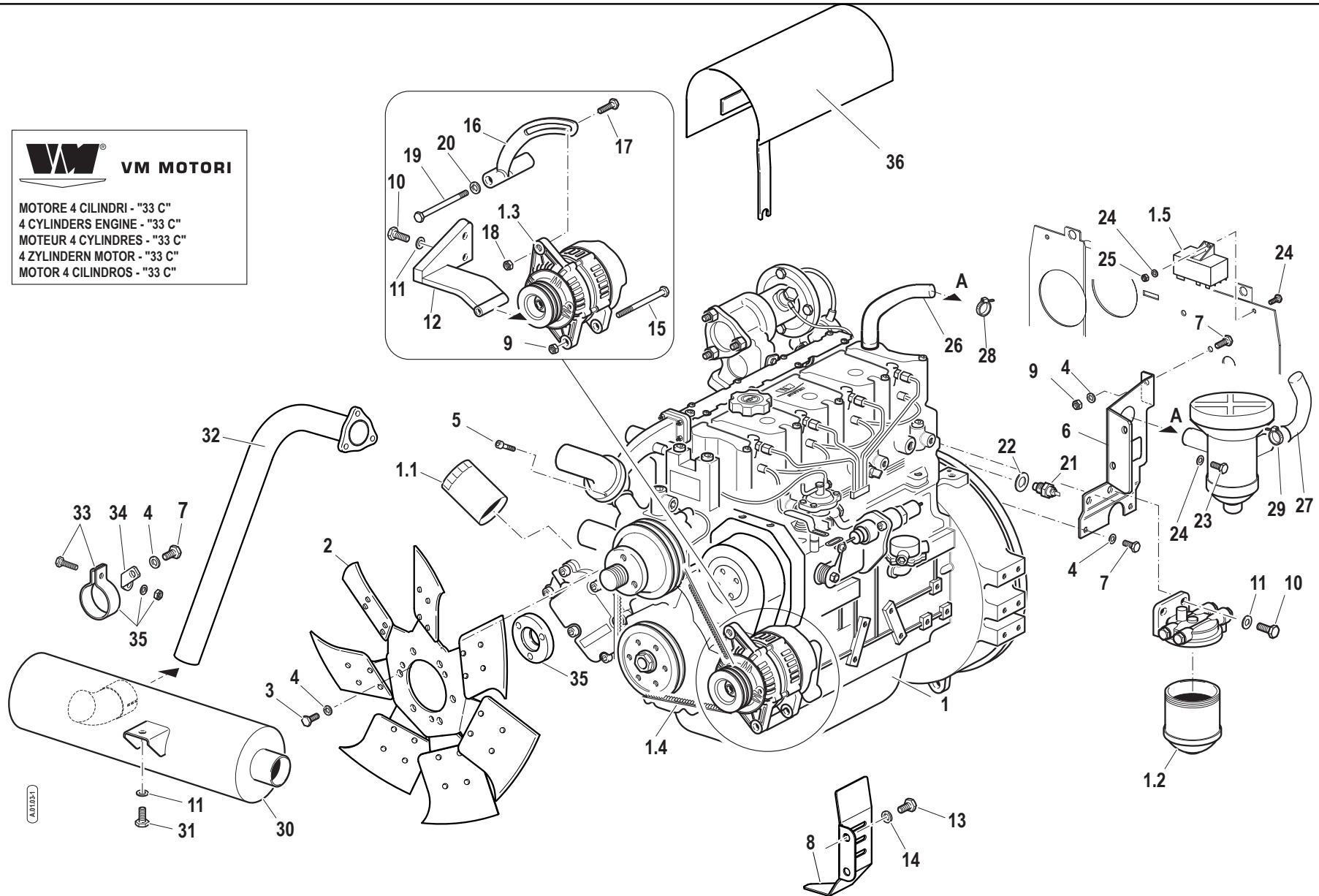



Pos.	Code	Q.ty	Description	Notes
1	41U70000	1	MOT.VM D754TE2.21A 67KW 33C/4	
1.1	58171199	1	OIL FILTER CARTRIDGE	
1.2	58171200	1	FUEL FILTER CARTRIDGE	
1.3	59900344	1	ALTERNATOR	
1.4	59900766	1	BELT	
1.5	59900345	1	CENTRAL PROCESSING UNIT	
2	58178646	1	FAN	
3	F0862694000	3	SCREW M8X170 UNI 5737	
4	F0843643060	7	WASHER 8	
5	F0862479035	1	SCREW	
6	59079167	1	RETAINER	
7	31111151	4	SCREW TE M8X16 UNI 5739 8G	
8	56177979	1	SHIELD	
9	31211080	2	NUT M8	
10	31112219	5	SCREW TE M10X25 UNI 5739	
11	F0843755000	6	WASHER 10	
12	59077318	1	SUPPORT	
13	31112082	2	SCREW TE M6X12 UNI 5739 8G	
14	31411064	2	WASHER 6,4x12,5	
15	31112174	1	SCREW TE M8X110 UNI 5737 8.8	
16	59076688	1	ROD	
17	31112153	1	SCREW TE M8X35 UNI 5739 8G	
18	31421083	1	WASHER	
19	F0864335020	1	SCREW M14X120 UNI 5737	
20	31421251	1	WASHER	
21	58175773	1	ELECTRONICAL THERMOMETER	
22	F0844030070	1	COPPER WASHER 16,0x22/1,5	
23	31112090	2	SCREW TE M6X16 UNI 5739 8G	
24	F0843570000	2	WASHER 6	
25	31211060	2	HEXAGONAL NUT M8	
26	55176744	1	PIPE	
27	58177400	1	OIL PIPE	
28	F0817500400	3	CLAMP 024,1-706R	
29	F0817500200	1	CLAMP 015,7-706R	

SERIAL

**ENGINE**  
Engine: 95 CV

CODE REV

**A.01.03\_1\_45644**

**VM MOTORI**

MOTORE 4 CILINDRI - "33 C"  
 4 CYLINDERS ENGINE - "33 C"  
 MOTEUR 4 CYLINDRES - "33 C"  
 4 ZYLINDER MOTOR - "33 C"  
 MOTOR 4 CILINDROS - "33 C"

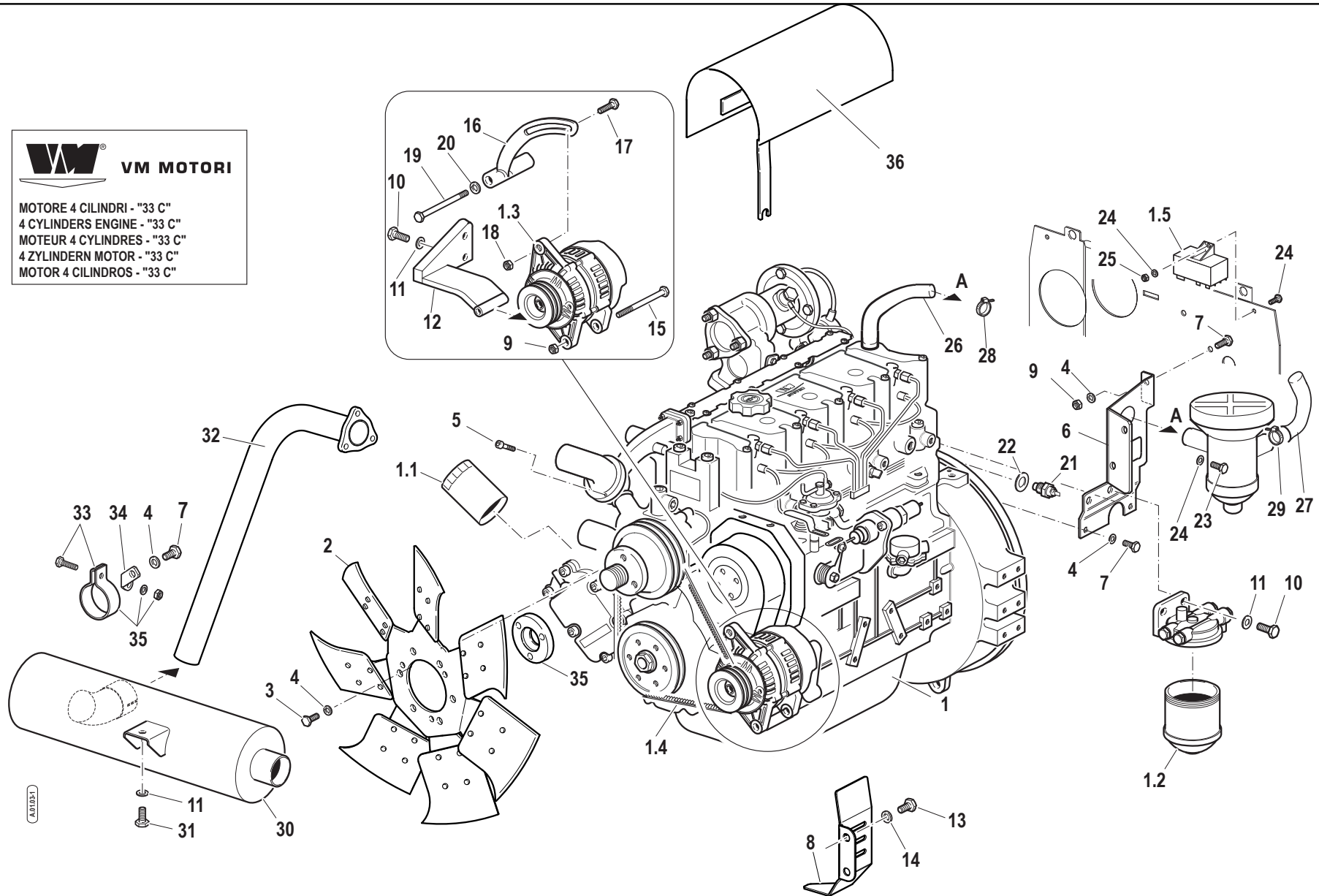

<b>Pos.</b>	<b>Code</b>	<b>Q.ty</b>	<b>Description</b>	<b>Notes</b>
30	58176618	1	EXHAUST SILENCER	
31	31112210	1	SCREW TE M10X20 UNI 5739	
32	59076619	1	EXHAUST	
33	58175121	1	COLLAR	
34	56177183	1	REINFORCED STRAP	
35	56178649	1	SPACER	
36	59076682	1	GUARD	

---

SERIAL

**ENGINE**  
Engine: 95 CV

CODE REV

**A.01.03\_1\_45644**

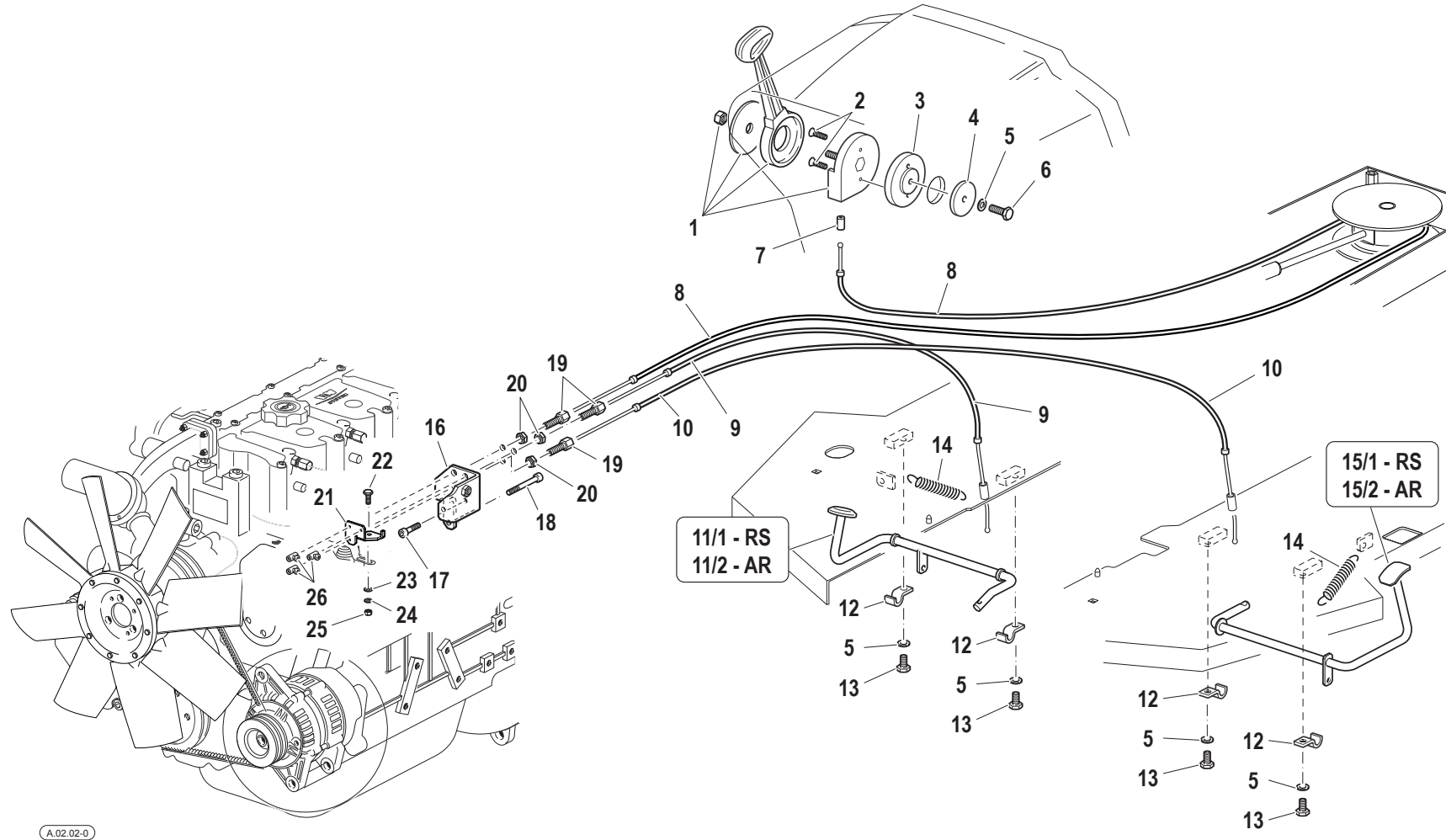

A.02.02-0

Pos.	Code	Q.ty	Description	Notes
1	F0828029070	1	ACCELERATOR	
2	31132562	2	SCREW TSVEI M6X16 UNI 5933	
3	56171877	1	FLANGE	
4	56171883	1	WASHER	
5	F0843643060	5	WASHER 8	
6	31112150	1	SCREW TE M8X20 UNI 5739 8G	
7	F0858520000	1	SLEEVE	
8	58078631	1	CABLE	
9	58072074	1	CABLE	
10	58072075	1	CABLE	
11/1	59074346	1	ACCEL. PEDAL	
11/2	59073681	1	ACCEL. PEDAL	
12	56071768	4	PLATE	
13	31112148	2	SCREW TE M8X18 UNI 5739 8G	
14	F0831125000	2	SPRING	
15/1	59074347	1	ACCEL. PEDAL	
15/2	59074213	1	ACCEL. PEDAL	
16	56174661	1	BRACKET	
17	31152060	1	SCREW TCEI M6X30 UNI 5931	
18	31152068	1	SCREW TCEI M6X55 UNI 5931	
19	56177656	3	REGISTER	
20	31231080	3	NUT M8	
21	56177655	1	BRACKET	
22	31112051	1	SCREW TE M5X14 UNI 5739 8G	
23	31411053	1	WASHER 5,3x10	
24	F0843561000	1	WASHER 5	
25	31211050	1	NUT M5	
26	58048002	3	CLAMPING SCREW	

COOLER

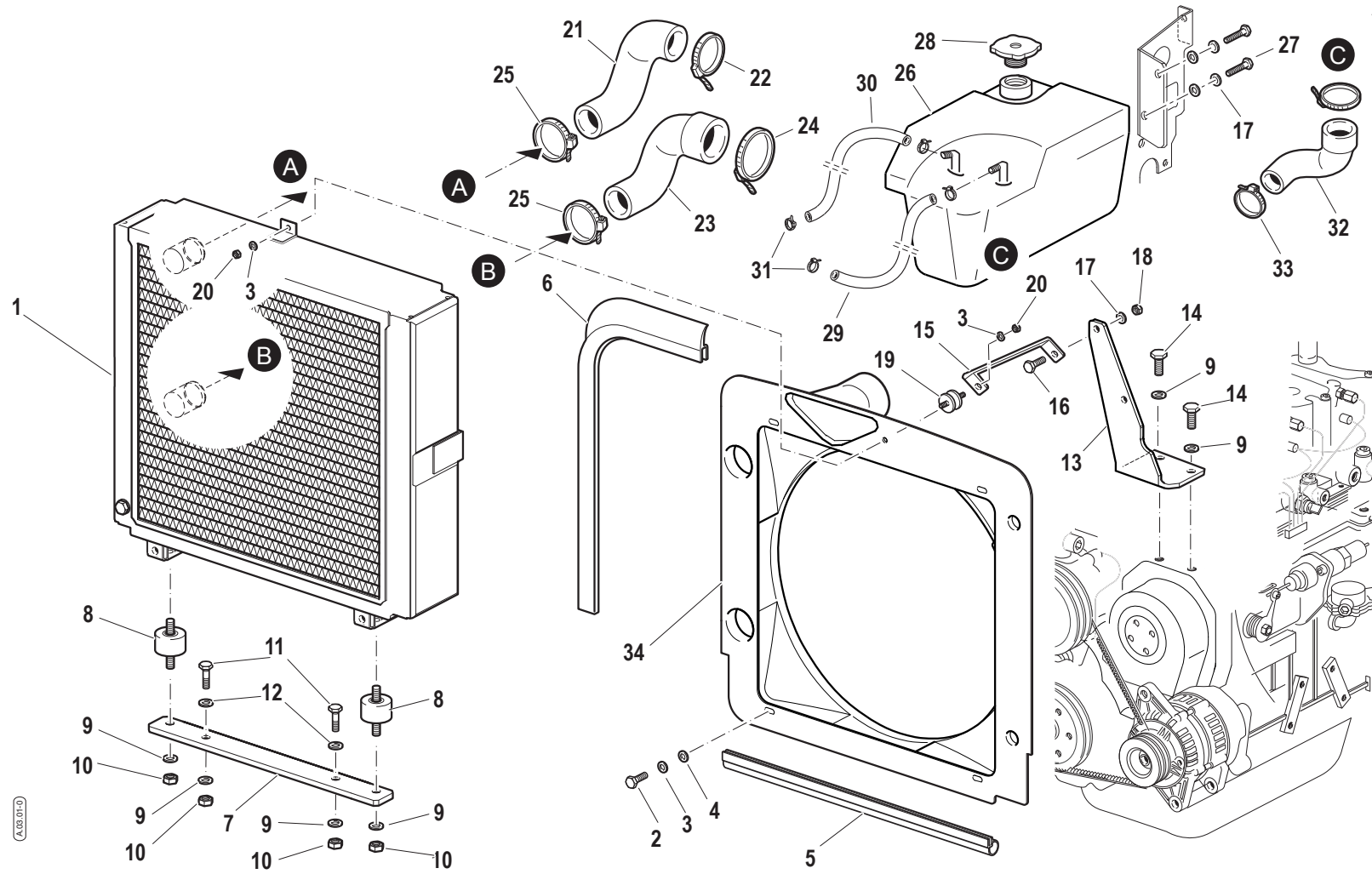

Pos.	Code	Q.ty	Description	Notes
1	58178586	1	RADIATOR	
2	31112082	4	SCREW TE M6X12 UNI 5739 8G	
3	F0843570000	6	WASHER 6	
4	31411064	4	WASHER 6,4x12,5	
5	28174882	1	GASKET	
6	F0256809050	1	GASKET	
7	56178805	1	BRACKET	
8	58174608	2	SILENT-BLOCK	
9	F0843755000	5	WASHER 10	
10	F0814632000	4	NUT M10	
11	31112212	2	SCREW TE M10X35 UNI 5739	
12	56178806	2	SPACER	
13	59076684	1	FIXING BRACKET	
14	31152103	1	SCREW TCEI M10X25 UNI 5931	
15	56176691	1	FIXING BRACKET	
16	31112151	1	SCREW TE M8X25 UNI 5739 8G	
17	F0843643060	3	WASHER 8	
18	31211080	1	NUT M8	
19	F0849206005	1	SILENT-BLOCK	
20	F0814545000	2	NUT M6	
21	55174632	1	SLEEVE	
22	F0817500500	1	CLAMP 048,5-706R	
23	55177639	1	SLEEVE	
24	F0817500700	1	CLAMP 057,5-706R	
25	F0817500470	2	CLAMP	
26	P236340000000	1	CUP	
27	31111151	2	SCREW TE M8X16 UNI 5739 8G	
28	P236220000000	1	PLUG	
29	58078677	1	VENT HOSE	
30	58075873	1	VENT HOSE	
31	F0817500200	4	CLAMP 015,7-706R	
32	58077132	1	PIPE	
33	F0817500400	2	CLAMP 024,1-706R	
34	58178638	1	DUCT	

SERIAL

**COOLER**  
Engine: 75 CV

CODE REV

**A.03.01\_0\_45689**

COOLER

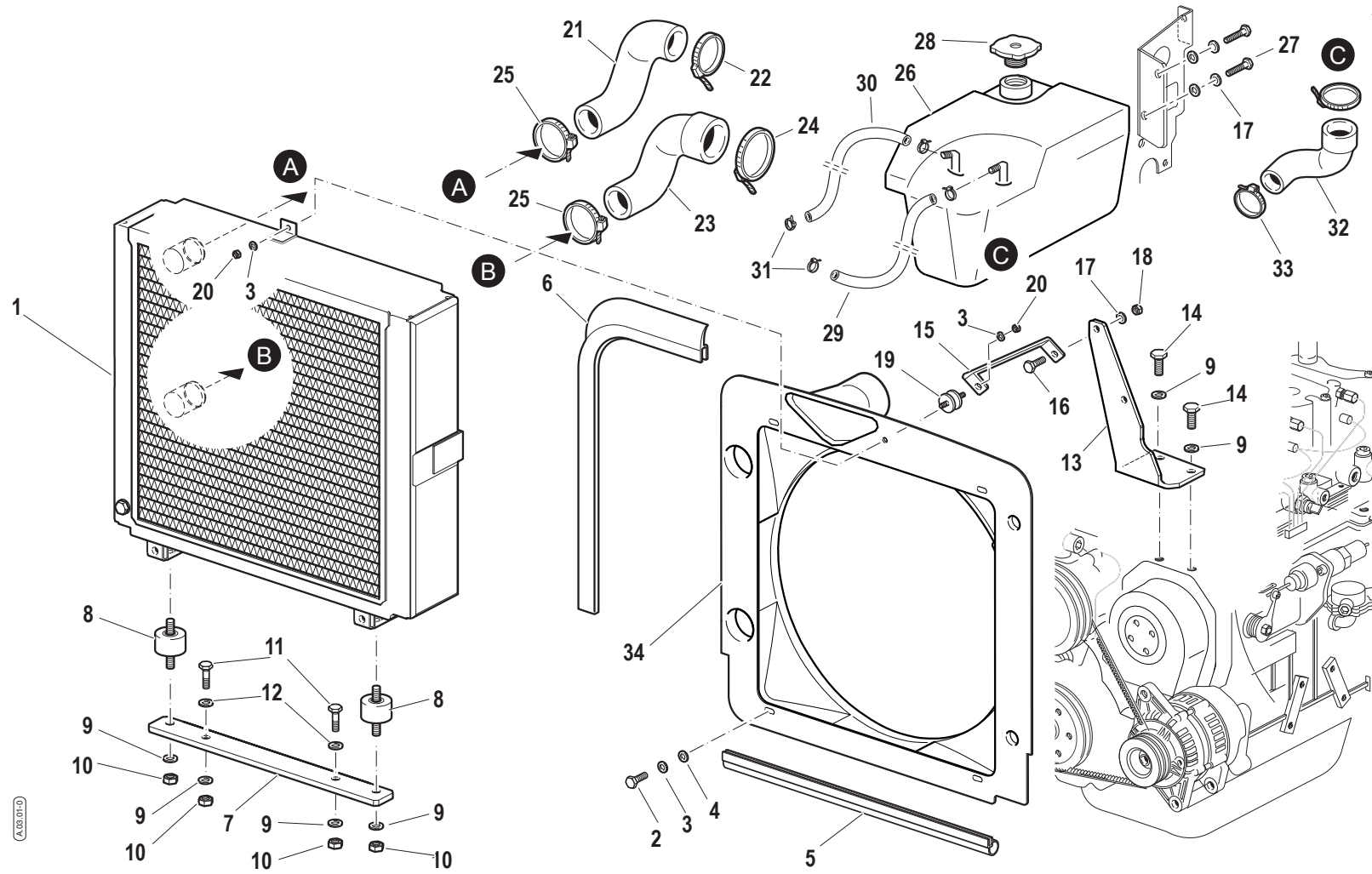



Pos.	Code	Q.ty	Description	Notes
35	31111091	4	SCREW E M6X14 UNI 5739 8G	
36	31211060	2	HEXAGONAL NUT M8	
37	31411066	6	WASHER 6,6x18	

---

SERIAL

**COOLER**  
Engine: 75 CV

CODE REV

**A.03.01\_0\_45689**

COOLER

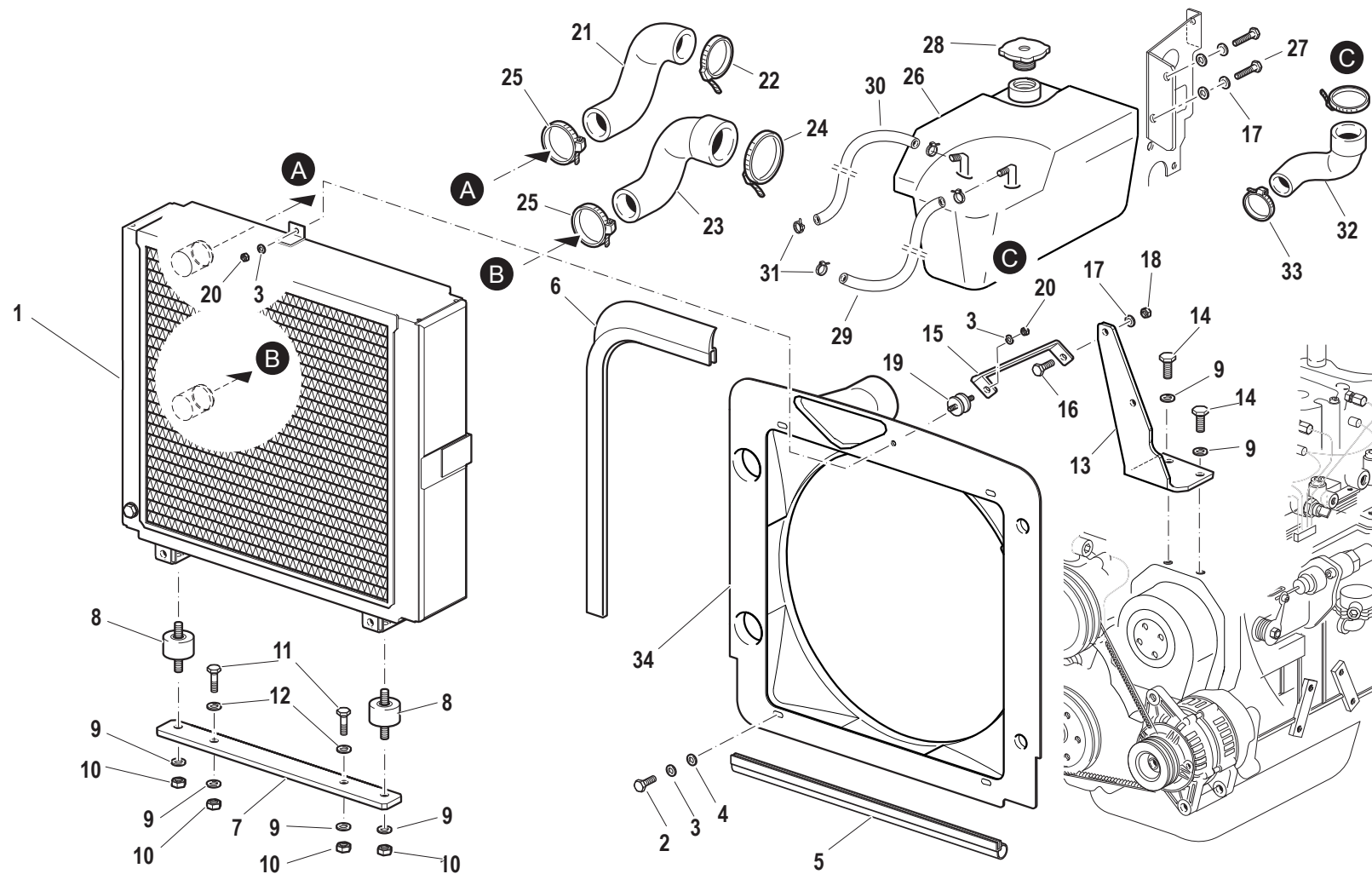

A.03.02.0

Pos.	Code	Q.ty	Description	Notes
1	58178585	1	RADIATOR	
2	31112082	4	SCREW TE M6X12 UNI 5739 8G	
3	F0843570000	6	WASHER 6	
4	31411064	4	WASHER 6,4x12,5	
5	28174882	1	GASKET	
6	F0256809050	1	GASKET	
7	56178805	1	BRACKET	
8	58174608	2	SILENT-BLOCK	
9	F0843755000	5	WASHER 10	
10	F0814632000	4	NUT M10	
11	31112212	2	SCREW TE M10X35 UNI 5739	
12	56178806	2	SPACER	
13	59076684	1	FIXING BRACKET	
14	31152103	1	SCREW TCEI M10X25 UNI 5931	
15	56176691	1	FIXING BRACKET	
16	31112151	1	SCREW TE M8X25 UNI 5739 8G	
17	F0843643060	3	WASHER 8	
18	31211080	1	NUT M8	
19	F0849206005	1	SILENT-BLOCK	
20	F0814545000	2	NUT M6	
21	55174632	1	SLEEVE	
22	F0817500500	1	CLAMP 048,5-706R	
23	55177639	1	SLEEVE	
24	F0817500700	1	CLAMP 057,5-706R	
25	F0817500470	2	CLAMP	
26	P236340000000	1	CUP	
27	31111151	2	SCREW TE M8X16 UNI 5739 8G	
28	P236220000000	1	PLUG	
29	58078677	1	VENT HOSE	
30	58075873	1	VENT HOSE	
31	F0817500200	4	CLAMP 015,7-706R	
32	58077132	1	PIPE	
33	F0817500400	2	CLAMP 024,1-706R	
34	58178638	1	DUCT	

SERIAL

**COOLER**  
Engine: 85 CV, 95 CV

CODE REV

**A.03.02\_0\_45727**

COOLER

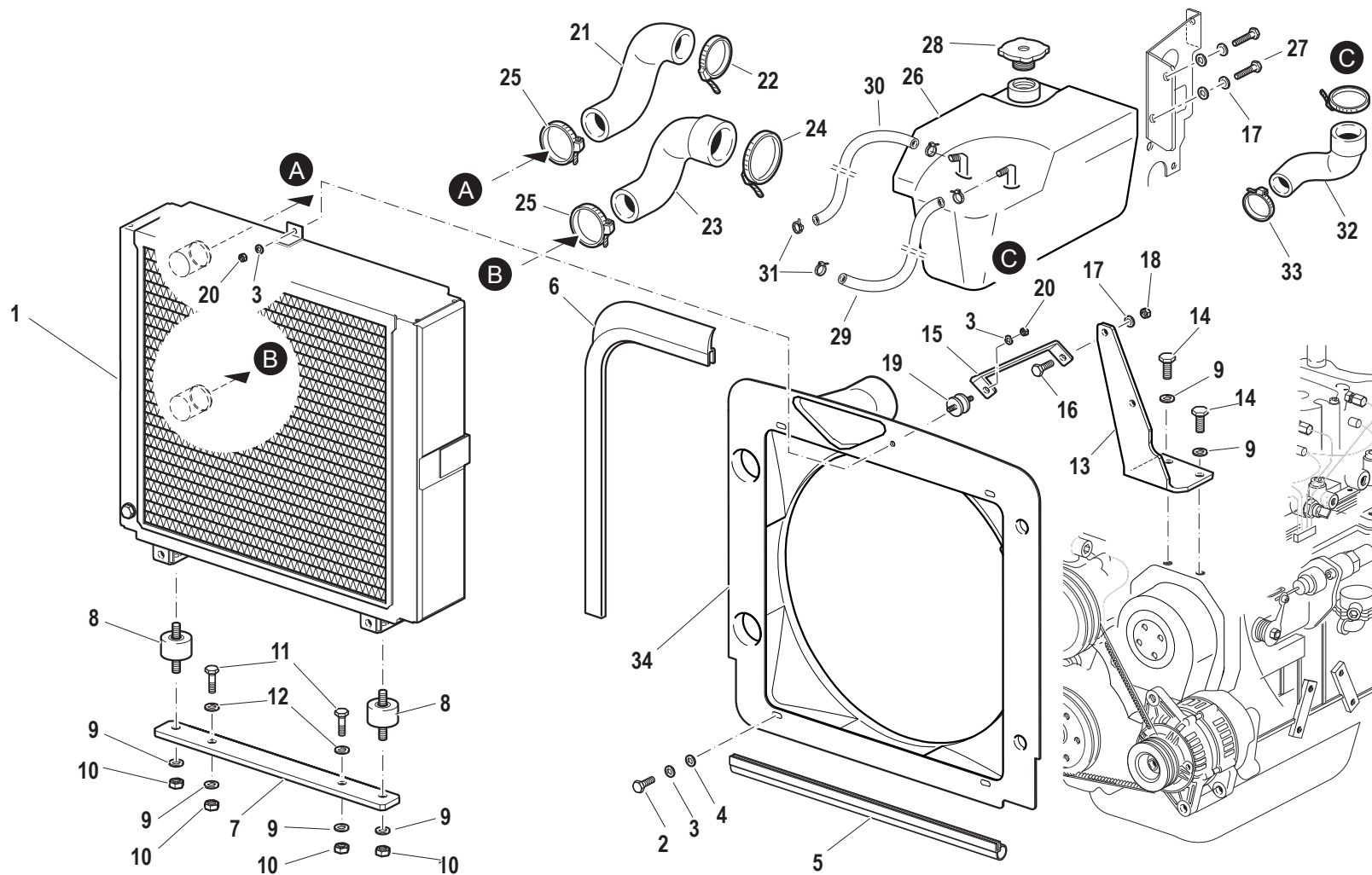

A.03.02.0

<b>Pos.</b>	<b>Code</b>	<b>Q.ty</b>	<b>Description</b>	<b>Notes</b>
35	31111091	4	SCREW E M6X14 UNI 5739 8G	
36	31211060	2	HEXAGONAL NUT M8	
37	31411066	6	WASHER 6,6x18	

---

SERIAL

**COOLER**  
Engine: 85 CV, 95 CV

CODE REV  
**A.03.02\_0\_45727**

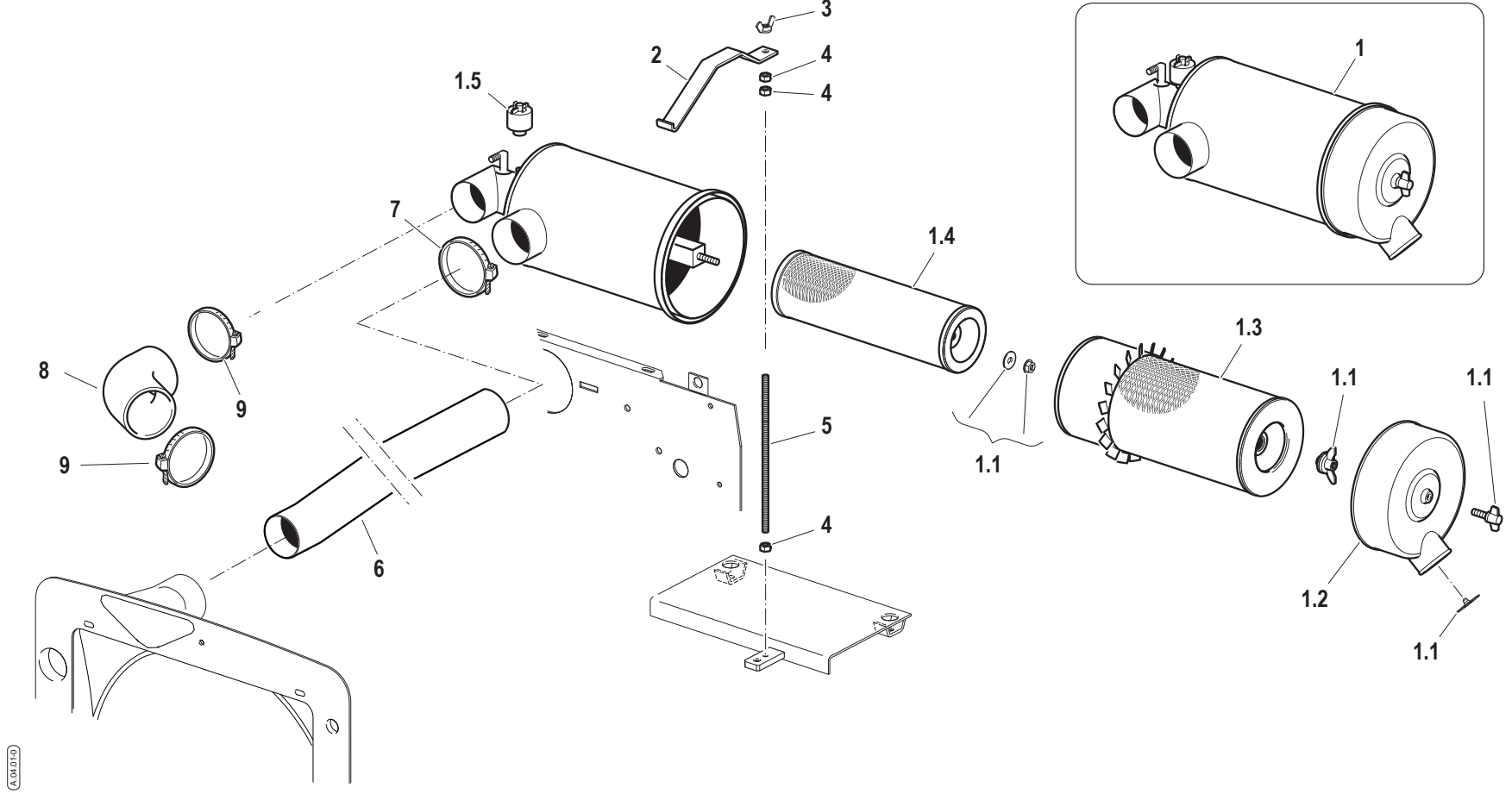

100000000

Pos.	Code	Q.ty	Description	Notes
1	58176755	1	AIR FILTER	
1.1	59900353	1	KIT	
1.2	59900347	1	COVER	
1.3	58171028	1	CARTOUCHE	
1.4	58171027	1	CARTOUCHE	
1.5	58175122	1	DIGITAL INSTRUMENT	
2	56174636	1	FIXING BRACKET	
3	31200501	1	NUT M8	
4	31211080	3	NUT M8	
5	56174635	1	ROD	
6	58076753	1	SUCTION PIPE	
7	F0817501200	1	CLAMP 077,0-706R	
8	58076751	1	SLEEVE	
9	F0817501000	2	CLAMP 072,5-706R	

SERIAL

**AIR FILTER**  
Engine: 75 CV

CODE REV

**A.04.01\_0\_45765**

# AIR FILTER WITH EXTERNAL AIR INTAKE

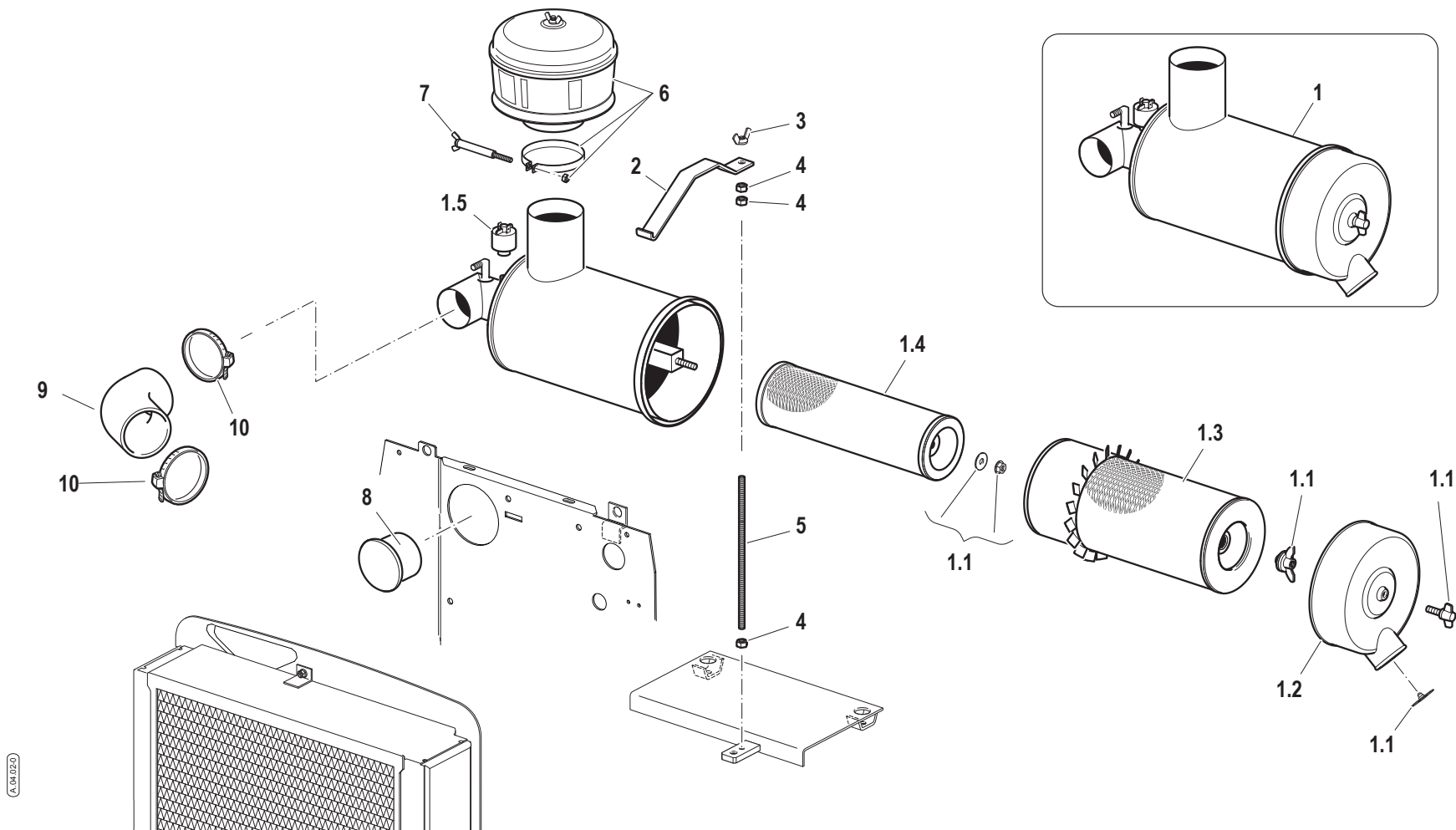



Pos.	Code	Q.ty	Description	Notes
1	58176898	1	AIR FILTER	
1.1	59900353	1	KIT	
1.2	59900347	1	COVER	
1.3	58171028	1	CARTOUCHE	
1.4	58171027	1	CARTOUCHE	
1.5	58175122	1	DIGITAL INSTRUMENT	
2	56174636	1	FIXING BRACKET	
3	31200501	1	NUT M8	
4	31211080	3	NUT M8	
5	56174635	1	ROD	
6	58171069	1	PRECLEANER	
7	59073184	1	SCREW	
8	57377317	1	PLUG	
9	58076751	1	SLEEVE	
10	F0817501000	2	CLAMP 072,5-706R	

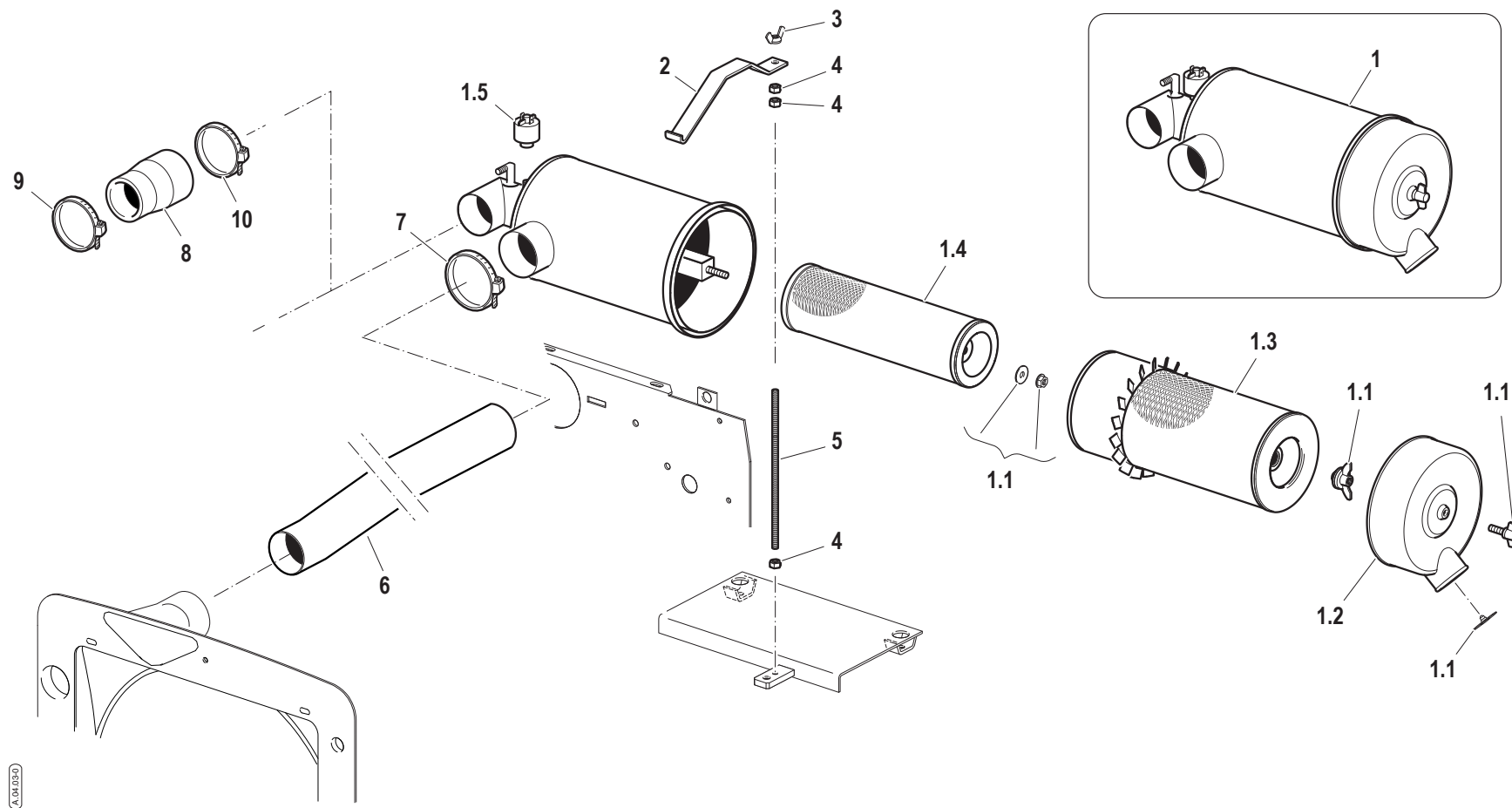

Pos.	Code	Q.ty	Description	Notes
1	58176755	1	AIR FILTER	
1.1	59900353	1	KIT	
1.2	59900347	1	COVER	
1.3	58171028	1	CARTOUCHE	
1.4	58171027	1	CARTOUCHE	
1.5	58175122	1	DIGITAL INSTRUMENT	
2	56174636	1	FIXING BRACKET	
3	31200501	1	NUT M8	
4	31211080	3	NUT M8	
5	56174635	1	ROD	
6	58076753	1	SUCTION PIPE	
7	F0817501200	1	CLAMP 077,0-706R	
8	58076750	1	SLEEVE	
9	F0817500800	1	CLAMP 062,0-706R	
10	F0817500900	1	CLAMP 069,5-706R	

SERIAL

**AIR FILTER**  
 Engine: 85 CV, 95 CV

CODE REV

**A.04.03\_0\_45796**

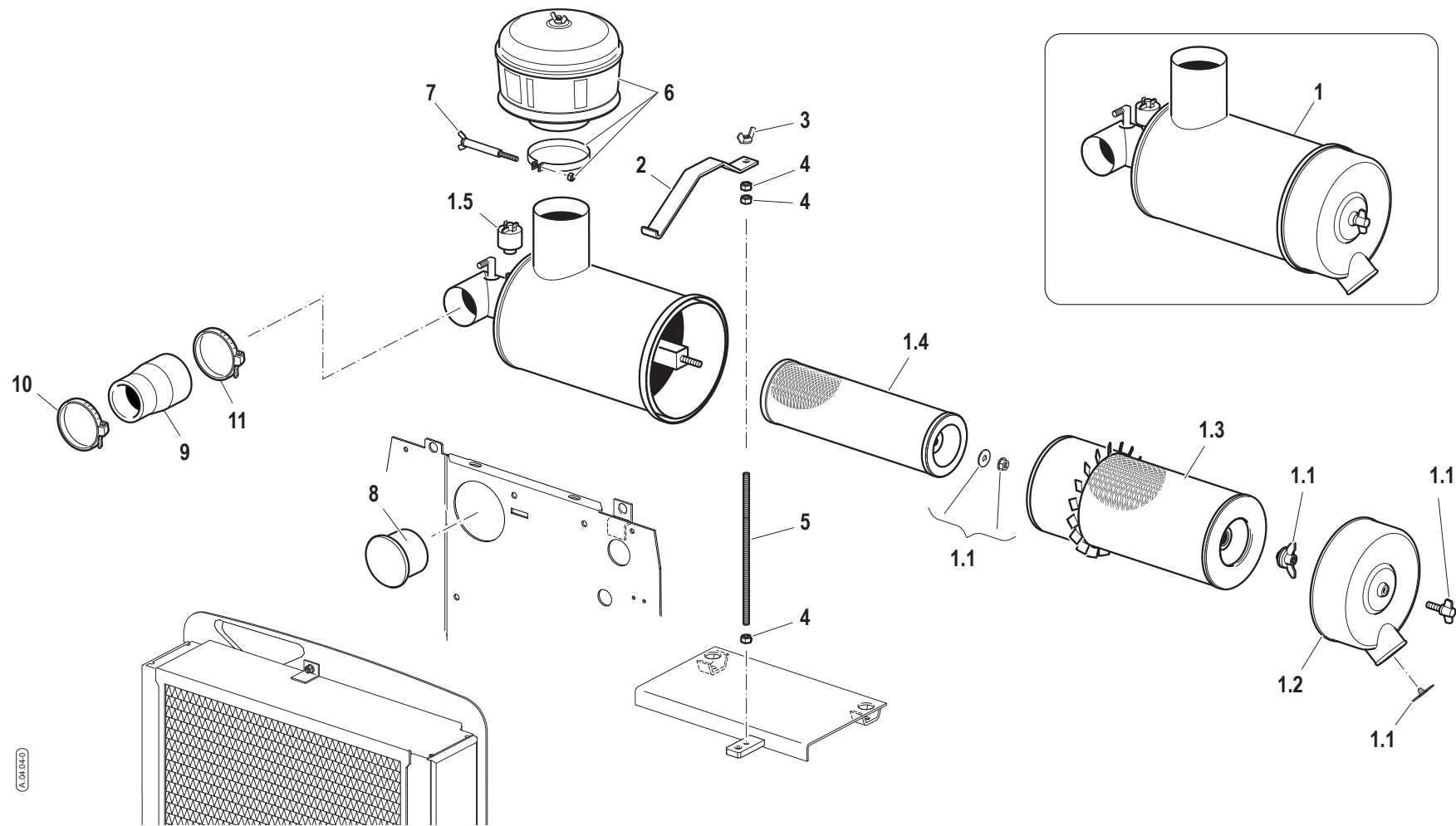

△ 04.04.12

Pos.	Code	Q.ty	Description	Notes
1	58176898	1	AIR FILTER	
1.1	59900353	1	KIT	
1.2	59900347	1	COVER	
1.3	58171028	1	CARTOUCHE	
1.4	58171027	1	CARTOUCHE	
1.5	58175122	1	DIGITAL INSTRUMENT	
2	56174636	1	FIXING BRACKET	
3	31200501	1	NUT M8	
4	31211080	3	NUT M8	
5	56174635	1	ROD	
6	58171069	1	PRECLEANER	
7	59073184	1	SCREW	
8	57377317	1	PLUG	
9	58076750	1	SLEEVE	
10	F0817500800	1	CLAMP 062,0-706R	
11	F0817500900	1	CLAMP 069,5-706R	



Pos.	Code	Q.ty	Description	Notes
1	55276745	1	TANK	
1.1	F0849500001	1	TANK COVER	
1.2	F0849500002	1	FILTER	
1.3	57174915	1	PIPE FITTING	
2	57371900	1	LINING	
3	58170238	1	CONTROL	
4	F0861867050	6	SCREW M4,2X19 DIN 7981	
5	56174635	1	ROD	
6	56077608	2	ROD	
7	56176716	1	SPACER	
8	56176696	2	SPACER D.14x9/155,5	
9	56176814	3	SPACER D.55x8/4	
10	31211080	6	NUT M8	
11	58076752	3	STOPPER	
12	59076685	1	BATTERY SUPPORT	
13	59077934	1	SUPPORT	
14	31111218	2	SCREW TE M10X140 UNI 5737 8G	
15	F0843755000	2	WASHER 10	
16	56170276	2	SPACER	
17	59077935	1	FIXING BRACKET	
18	F0862481000	2	SCREW M8x16 UNI 5933	
19	58070690	1	PIPE	
20	F0817500200	4	CLAMP 015,7-706R	
21	58074895	1	PIPE	
22	58171901	1	CABLE GLAND 15,5-24-32-2	
23	59076679	1	DIVISION	
24	F0862464050	2	SCREW UNI 5931	
25	F0825414000	2	CABLE GLAND 7-15-18,5-2,5	
26	59076686	1	BRACKET	
27	31112096	2	SCREW TE M6X85 UNI 5737 8G	
28	F0843570000	2	WASHER 6	
29	31111151	1	SCREW TE M8X16 UNI 5739 8G	
30	F0843643060	1	WASHER 8	
31	F0256808000	1	FLAT BAND	

SERIAL

**FUEL TANK**

CODE REV

**A.05.02\_0\_45864**

FRONT SUPPORT

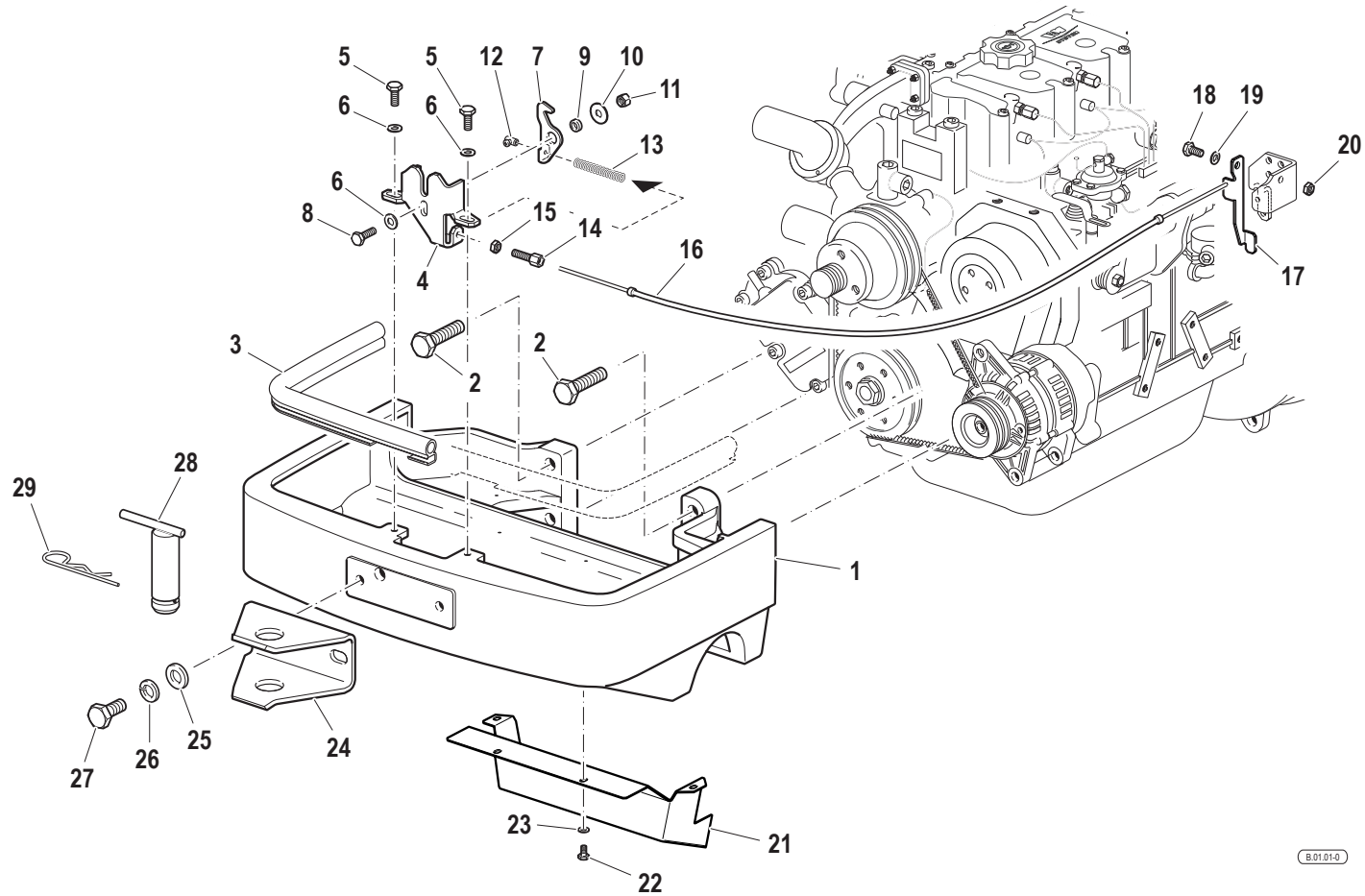



Pos.	Code	Q.ty	Description	Notes
1	51176714	1	FRONT SUPPORT	
2	31111331	4	SCREW TE M14X50 UNI5739 8G	
3	58177274	1	HOOD SEAL	
4	56174657	1	FIXING BRACKET	
5	31112150	2	SCREW TE M8X20 UNI 5739 8G	
6	31411084	3	WASHER 8,4x17	
7	56174658	1	HOOD HOOK	
8	31112151	1	SCREW TE M8X25 UNI 5739 8G	
9	56174659	1	SPACER	
10	31411090	1	WASHER 9x24	
11	31241080	1	HEXAGON SELFLOCK NUT M8	
12	58048002	1	CLAMPING SCREW	
13	F0831065000	1	SPRING	
14	56177656	1	REGISTER	
15	31231080	1	NUT M8	
16	58074831	1	CABLE	
17	56177643	1	LEVER	
18	31111151	1	SCREW TE M8X16 UNI 5739 8G	
19	F0843643060	1	WASHER 8	
20	F0814569000	1	NUT	
21	59076756	1	SHIELD	
22	31112082	12	SCREW TE M6X12 UNI 5739 8G	
23	F0843570000	12	WASHER 6	
24	56174873	1	TOW HOOK	
25	31112328	2	SCREW TE M14X35 UNI 5739	
26	F0843921030	2	WASHER 14	
27	31411150	2	WASHER 15x28	
28	59075283	1	PIN	
29	F0851497000	1	SPLIT PIN	

# BONNET

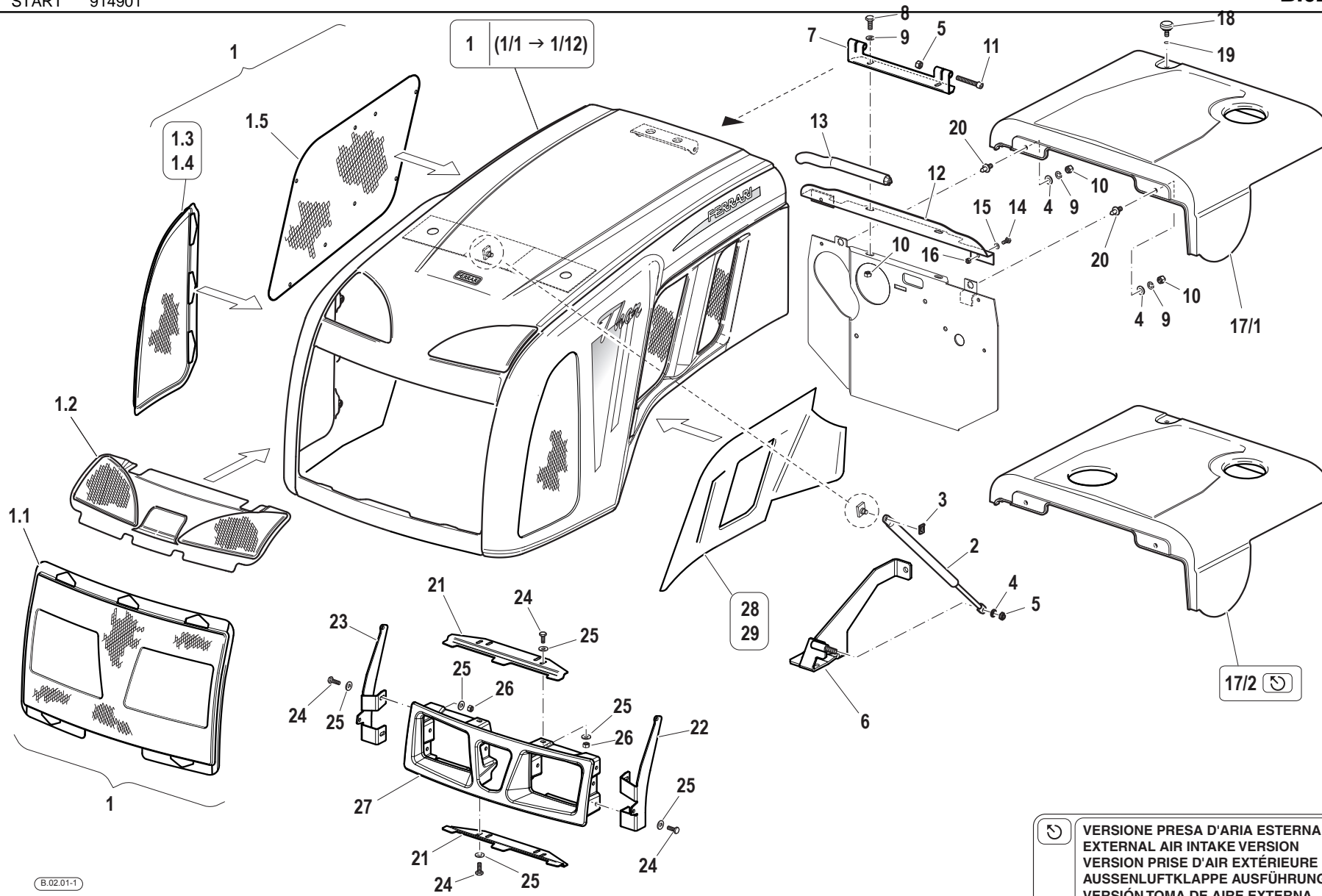

↻  
VERSIONE PRESA D'ARIA ESTERNA  
EXTERNAL AIR INTAKE VERSION  
VERSION PRISE D'AIR EXTÉRIEURE  
AUSSENLUFTKLAPPE AUSFÜHRUNG  
VERSIÓN TOMA DE AIRE EXTERNA

Pos.	Code	Q.ty	Description	Notes
1.1	56079442	1	FRONT GRILL	
1/1	59900975	1	COMPLETE HOOD	
1/10	59900985	1	COMPLETE HOOD	
1/11	59900980	1	COMPLETE HOOD	
1/12	59900986	1	COMPLETE HOOD	
1/2	59900981	1	COMPLETE HOOD	
1.2	56076933	1	FRONT GRILL	
1.3	56076928	1	FRONT GRILL	
1/3	59900976	1	COMPLETE HOOD	
1/4	59900982	1	COMPLETE HOOD	
1.4	56076929	1	FRONT GRILL	
1.5	56076930	1	GRILLE	
1/5	59900977	1	COMPLETE HOOD	
1/6	59900983	1	COMPLETE HOOD	
1/7	59900978	1	COMPLETE HOOD	
1/8	59900984	1	COMPLETE HOOD	
1/9	59900979	1	COMPLETE HOOD	
2	58092972	1	SPRING	
3	58170436	1	CLIP	
4	31411084	6	WASHER 8,4x17	
5	F0814585000	3	SELFLOCK NUT	
6	59076686	1	BRACKET	
7	56179549	1	PROTECTIVE YOKE	
8	31112150	2	SCREW TE M8X20 UNI 5739 8G	
9	F0843643060	6	WASHER 8	
10	31211080	6	NUT M8	
11	31152088	2	SCREW TCEI M8X55 UNI 5931	
12	56174656	1	HOLDING	
13	P000000260007	1	GASKET	
14	31111091	2	SCREW E M6X14 UNI 5739 8G	
15	F0843570000	2	WASHER 6	
16	31211060	2	HEXAGONAL NUT M8	
17/1	57376670	1	COVER	
17/2	57376899	1	COVER	

SERIAL  
START  
**914901**

**BONNET**

CODE REV

**B.02.01\_1\_47161**

# BONNET

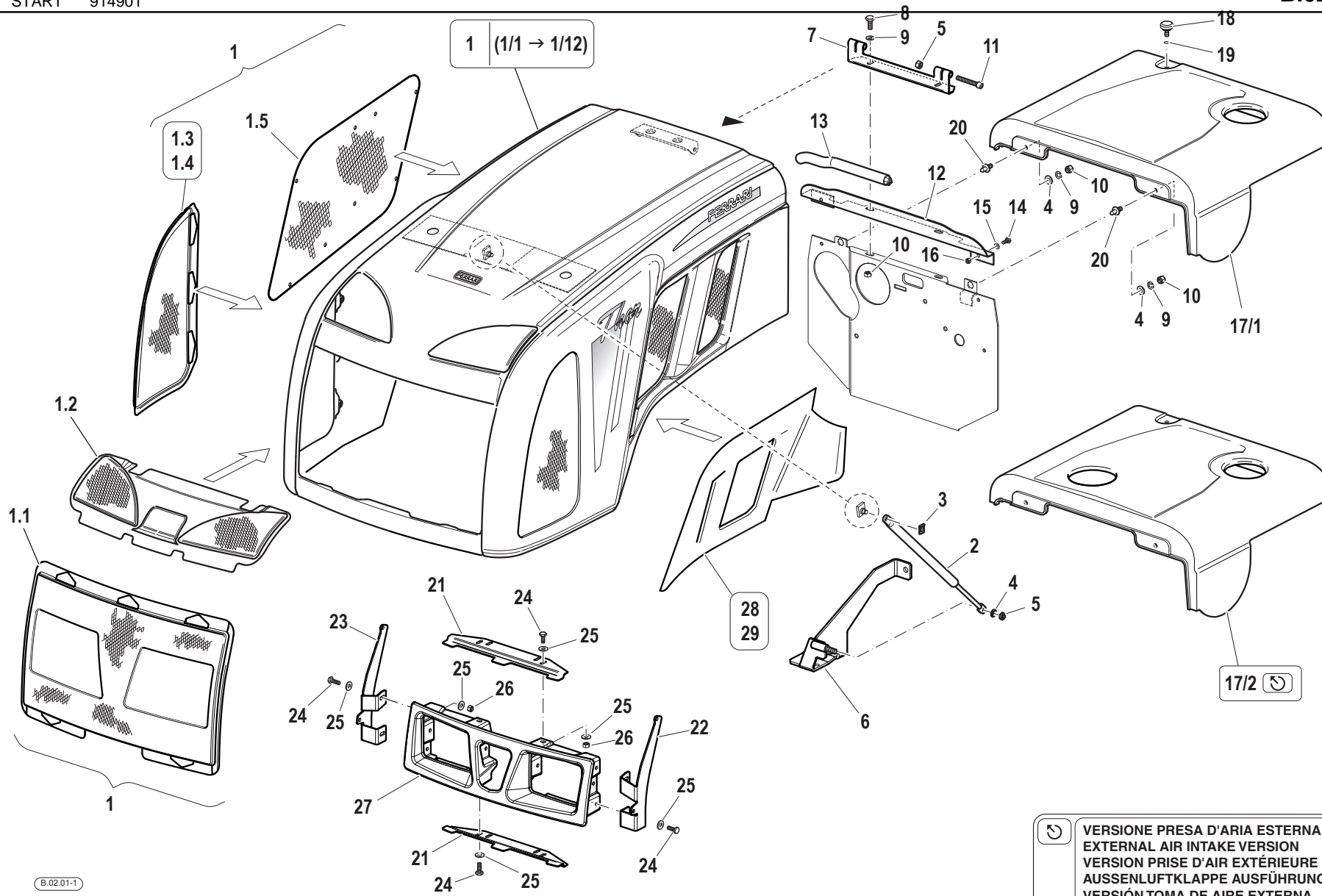

↻  
VERSIONE PRESA D'ARIA ESTERNA  
EXTERNAL AIR INTAKE VERSION  
VERSION PRISE D'AIR EXTÉRIEURE  
AUSSENLUFTKLAPPE AUSFÜHRUNG  
VERSIÓN TOMA DE AIRE EXTERNA

Pos.	Code	Q.ty	Description	Notes
18	56174835	1	KNOB	
19	35211060	1	SEEGER RING	
20	59074662	6	PIN	
21	56179447	2	SUPPORTING YOKE	
22	56179443	1	FIXING BRACKET	
23	56179444	1	BRACKET	
24	31112093	8	SCREW TE M6X20	
25	31411066	16	WASHER 6,6x18	
26	F0814547000	8	SELFLOCK NUT M6	
27	57379438	1	FRONT GRILLE	
28	58076984V	1	FIANCHETTO DX VERDE 75-95 **	
29	58076987V	1	FIANCHETTO SX VERDE 75-95 **	

FRONT MUDGUARDS

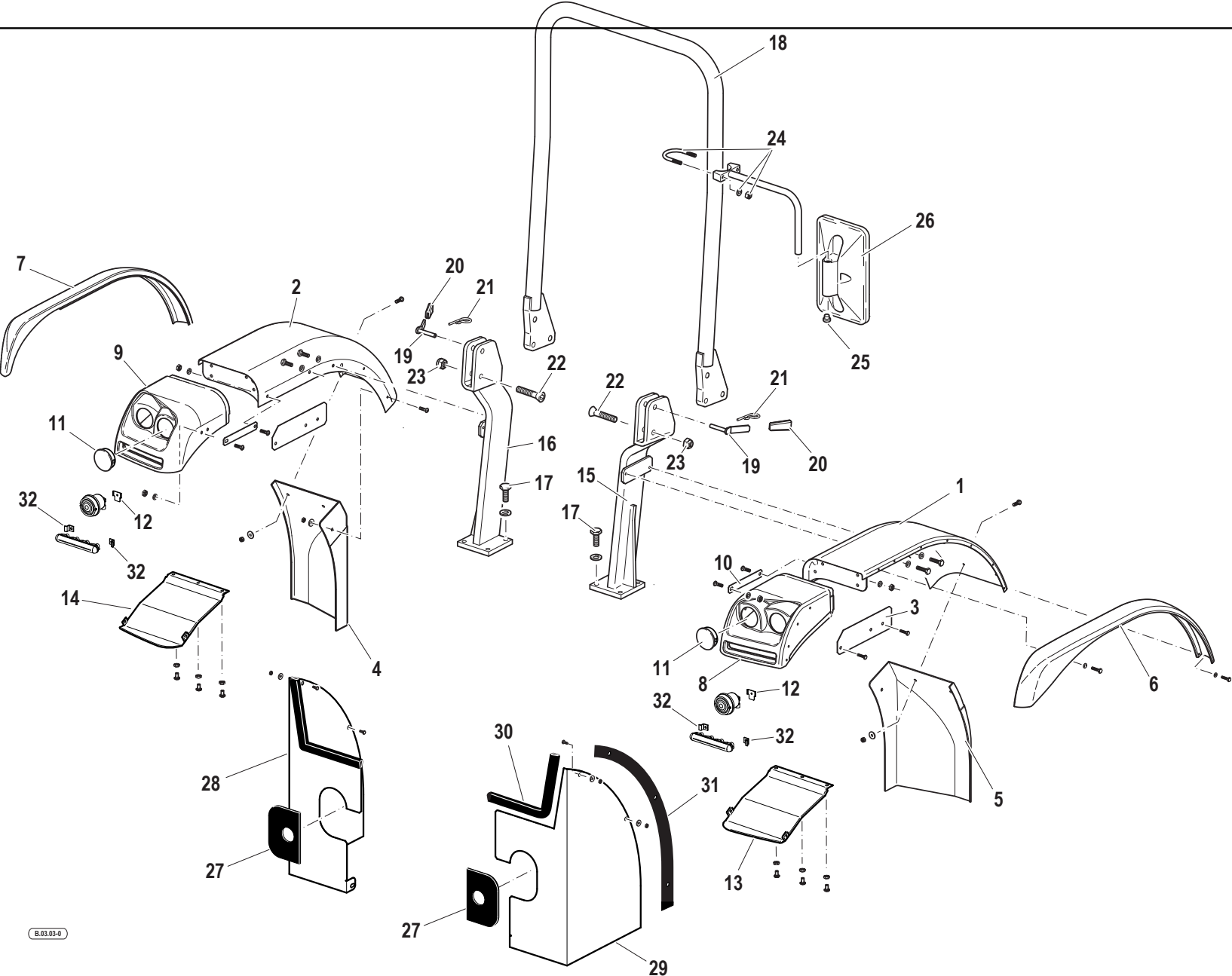

Pos.	Code	Q.ty	Description	Notes
1	59076645V	1	LEFT FRONT FENDER	
2	59076641V	1	RIGHT FRONT FENDER	
3	56177256	2	GUARD	
4	57374522	1	WING EXTENSION	
5	57374523	1	WING EXTENSION	
6	57376675	1	WING EXTENSION	
7	57376676	1	WING EXTENSION	
8	57376621	1	SUPPORT	
9	57376622	1	SUPPORT	
10	56177326	2	RETAINER	
11	58179414	2	PLUG	
12	56179445	1	FIXING PLATE	
13	56176906	1	COVER	
14	56176905	1	COVER	
15	59076616	1	SUPPORT	
16	59076614	1	SUPPORT	
17	31112264	8	SCREW TE M12X35 UNI 5739	
18	59076612	1	SAFETY ROLL BAR	
19	59076690	2	HINGE PIN	
20	P917280000000	2	GRIP	
21	P439149000000	2	SPLIT PIN	
22	F0864377000	2	SCREW M16X70 UNI 5737	
23	F0814794000	2	SELFLOCK NUT M16 CL.6	
24	59070591	1	SUPPORT	
25	58170968	1	PLUG	
26	30000514	1	REAR VIEW MIRROR	
27	57376900	2	SHEATH	
28	59076902	1	STRIKER PLATE	
29	59076903	1	STRIKER PLATE	
30	F0256808000	1	FLAT BAND	
31	F0256910000	1	FOAM PROFILE 5X20	
32	56177045	8	RETAINER	

SERIAL

**FRONT MUDGUARDS**

CODE REV

**B.03.03\_0\_50588**

FRONT MUDGUARDS (VERSION WITH CAB)

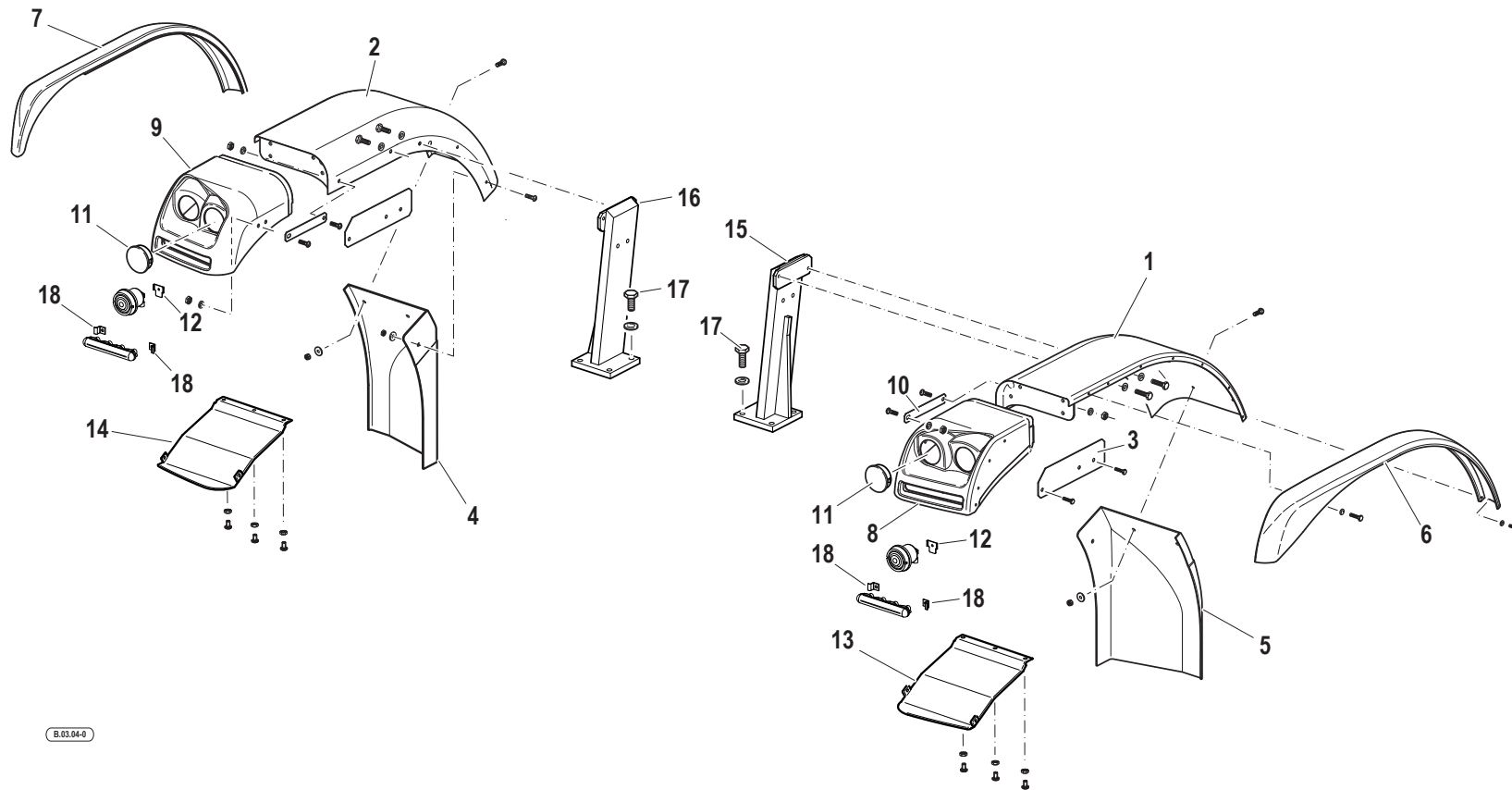



Pos.	Code	Q.ty	Description	Notes
1	59076645V	1	LEFT FRONT FENDER	
2	59076641V	1	RIGHT FRONT FENDER	
3	56177256	2	GUARD	
4	57374522	1	WING EXTENSION	
5	57374523	1	WING EXTENSION	
6	57376675	1	WING EXTENSION	
7	57376676	1	WING EXTENSION	
8	57376621	1	SUPPORT	
9	57376622	1	SUPPORT	
10	56177326	2	RETAINER	
11	58179414	2	PLUG	
12	56179445	1	FIXING PLATE	
13	56176906	1	COVER	
14	56176905	1	COVER	
15	59077055	1	WING HOLDER	
16	59077056	1	WING HOLDER	
17	31112264	8	SCREW TE M12X35 UNI 5739	
18	56177045	8	RETAINER	

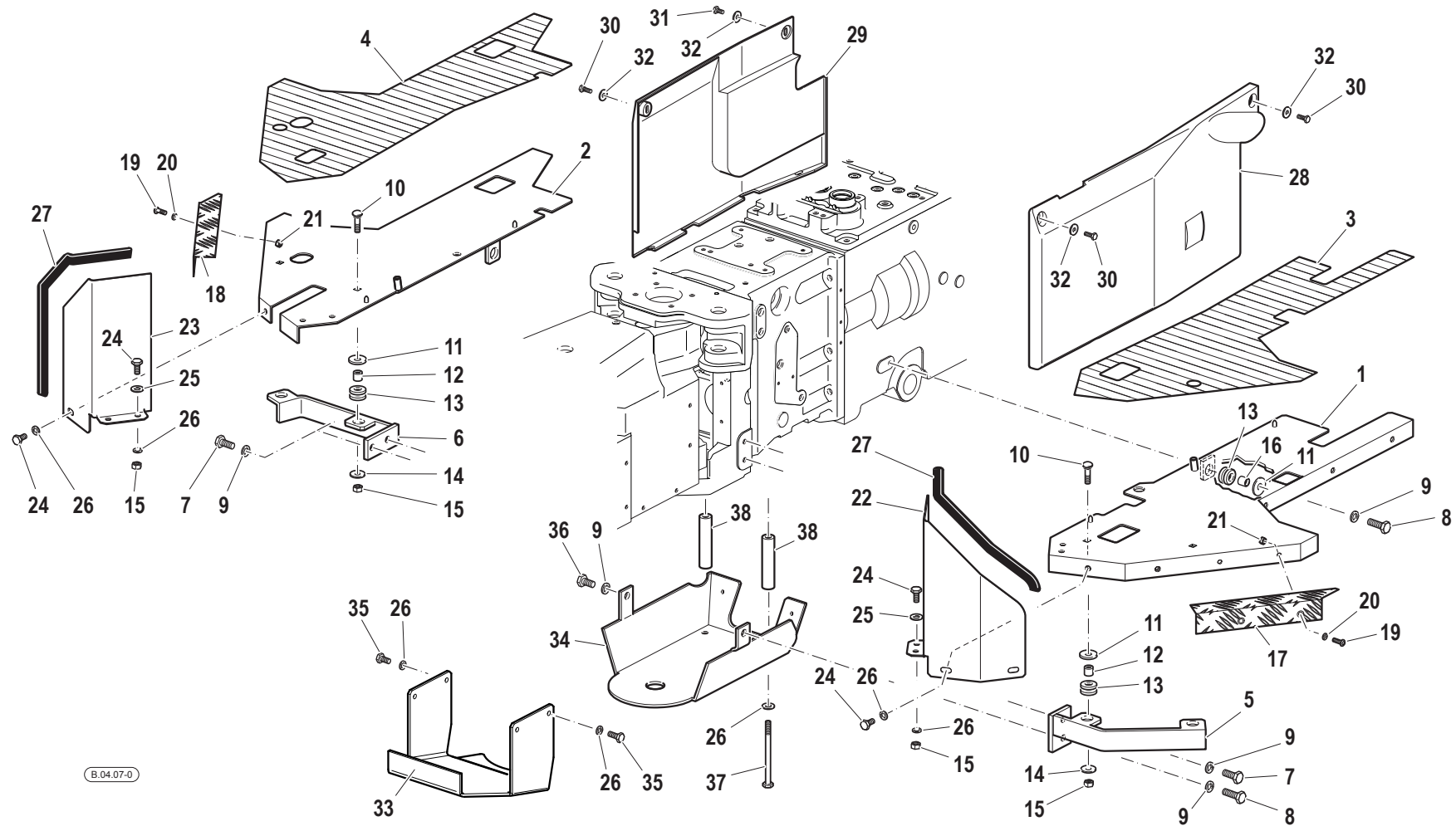

B.04.07-0

Pos.	Code	Q.ty	Description	Notes
1	59074598	1	LEFT FOOTBOARD	
2	59074599	1	RIGHT FOOTBOARD	
3	57374594	1	FOOTREST COVER	
4	57374595	1	FOOTREST COVER	
5	59073678	1	SUPPORT	
6	59073674	1	SUPPORT	
7	31112219	3	SCREW TE M10X25 UNI 5739	
8	31112211	3	SCREW TE M10X30 UNI 5739	
9	F0843755000	7	WASHER 10	
10	31122804	4	SCREW	
11	F0843818000	6	WASHER	
12	56171996	4	SPACER	
13	55175174	6	BLOCK	
14	31411090	4	WASHER 9x24	
15	31211080	8	NUT M8	
16	56171954	2	SPACER	
17	57275029	1	ANGULAR	
18	57275031	1	ANGULAR	
19	F0862479035	4	SCREW	
20	F0843570000	4	WASHER 6	
21	31211060	4	HEXAGONAL NUT M8	
22	56174667	1	FOOTBOARD PROTECTION	
23	56174666	1	FOOTBOARD PROTECTION	
24	31111151	8	SCREW TE M8X16 UNI 5739 8G	
25	31411084	4	WASHER 8,4x17	
26	F0843643060	14	WASHER 8	
27	F0256808000	1	FLAT BAND	
28	57374506	1	GUARD	
29	57374507	1	GUARD	
30	F0862479035	3	SCREW	
31	F0862479034	1	SCREW M6X12 7380	
32	31411066	4	WASHER 6,6x18	
33	56078831	1	SHIELD	
34	59075716	1	SHIELD	

SERIAL

**BOARDS**

CODE REV

**B.04.07\_0\_40076**

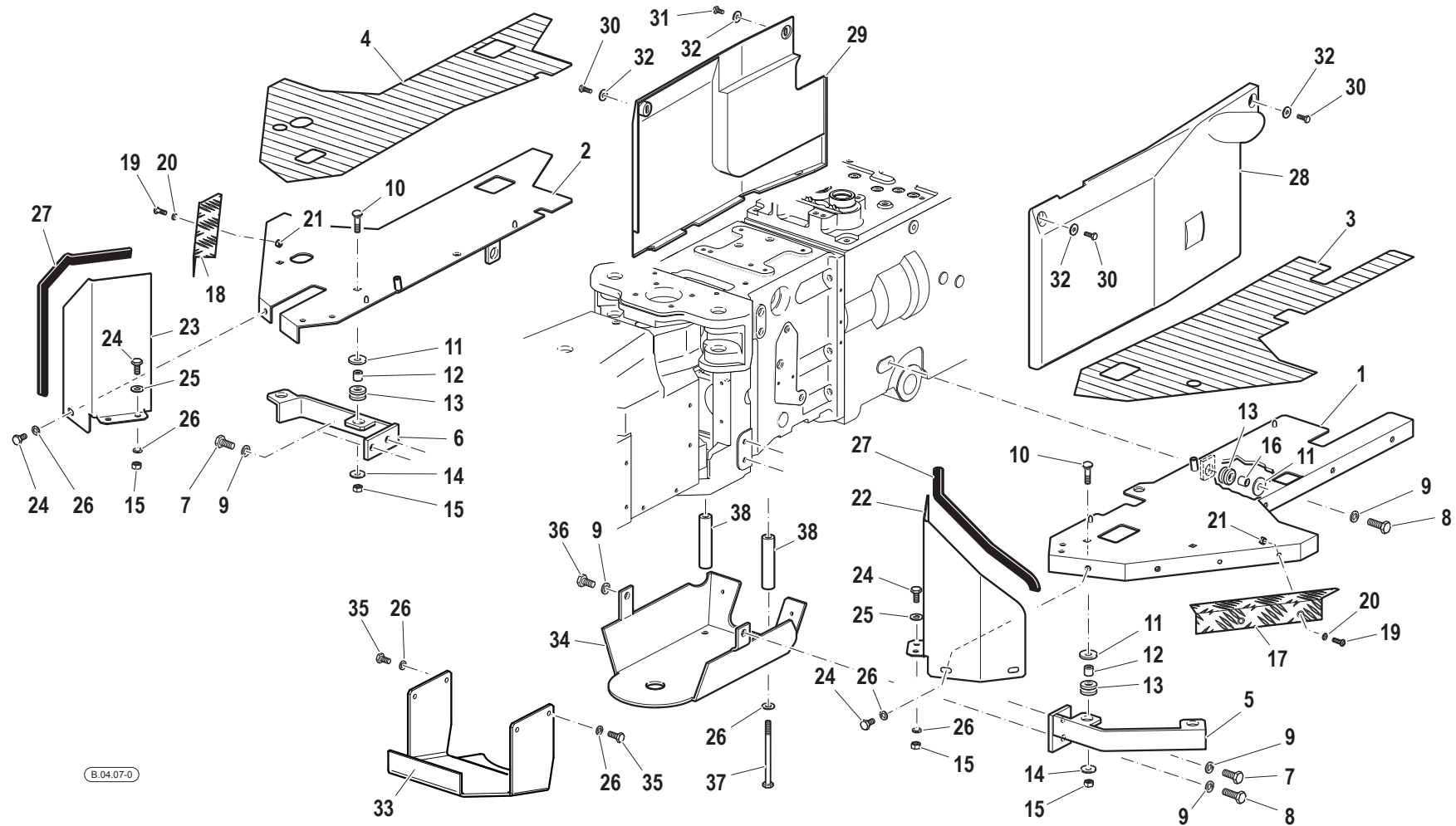

B.04.07-0

<b>Pos.</b>	<b>Code</b>	<b>Q.ty</b>	<b>Description</b>	<b>Notes</b>
35	31112150	4	SCREW TE M8X20 UNI 5739 8G	
36	31112210	1	SCREW TE M10X20 UNI 5739	
37	31112178	2	SCREW TE M8X130 UNI 5737	
38	56178560	2	SPACER	

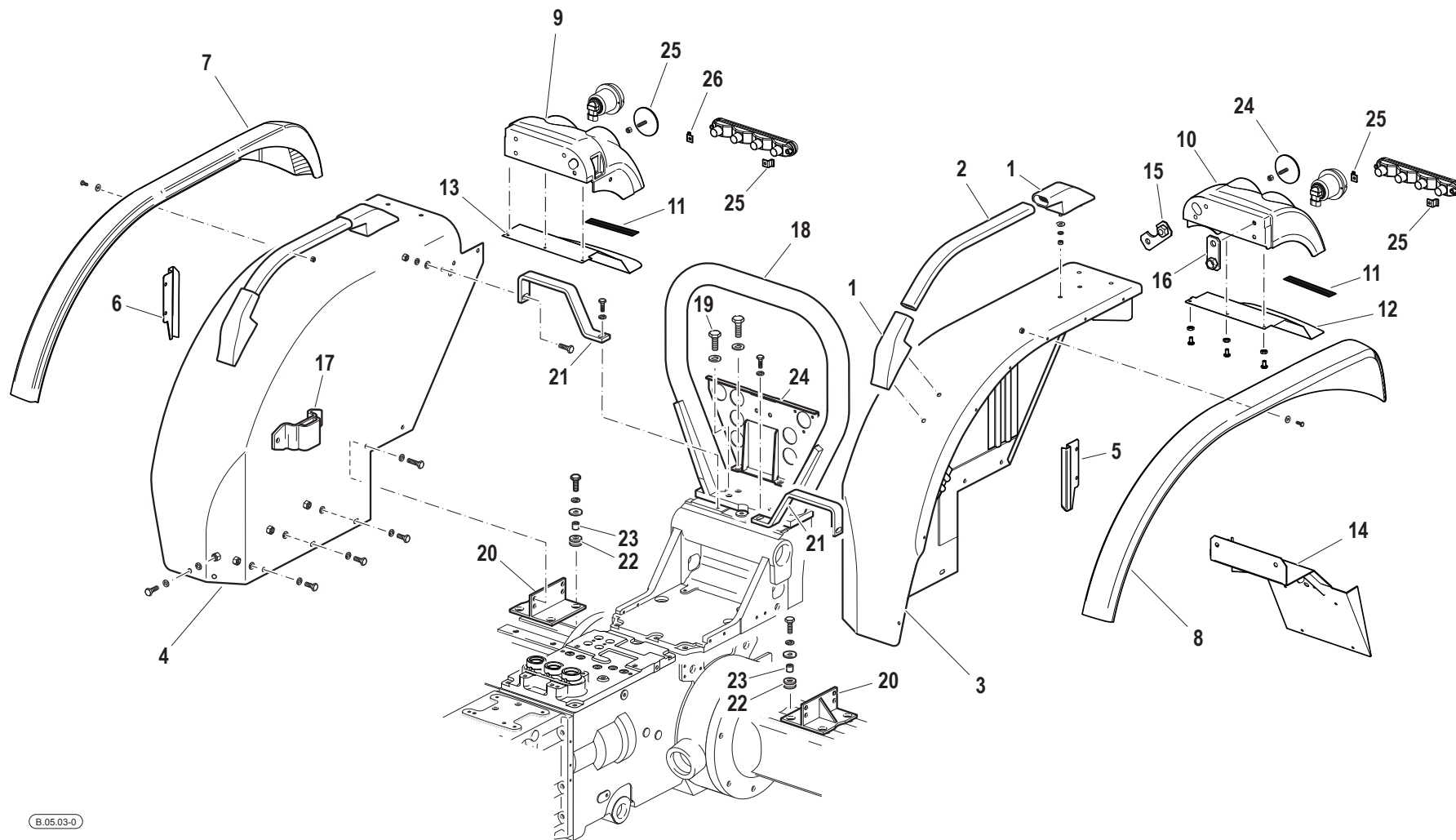

Pos.	Code	Q.ty	Description	Notes
1	55072935	4	SUPPORT	
2	56177252	2	MUDGUARD HANDLE	
3	59077445V	1	LEFT REAR FENDER	
4	59077449V	1	RIGHT REAR FENDER	
5	56177443	1	GUARD	
6	56177444	1	GUARD	
7	57377704	1	WING EXTENSION	
8	57377707	1	WING EXTENSION	
9	57376623	1	SUPPORT	
10	57376624	1	SUPPORT	
11	F0256910010	1	CELL FOAM PROFILE 10X15	
12	56176908	1	COVER	
13	56176907	1	COVER	
14	59076780	1	LICENCE PLATE HOLD	
15	56177264	1	RETAINING PLATE	
16	56177265	1	RETAINING PLATE	
17	59070592	1	LEVER BEARING	
18	59077359	1	SAFETY ROLL BAR	
19	31112801	4	SCREW M14x1,5x40 U/5740	
20	59077474	2	FIXING BRACKET	
21	56177475	2	FIXING BRACKET	
22	55175174	8	BLOCK	
23	56171954	8	SPACER	
24	59071966	1	CONNECTION	
25	58177330	2	REFLECTOR	
26	56177045	8	RETAINER	

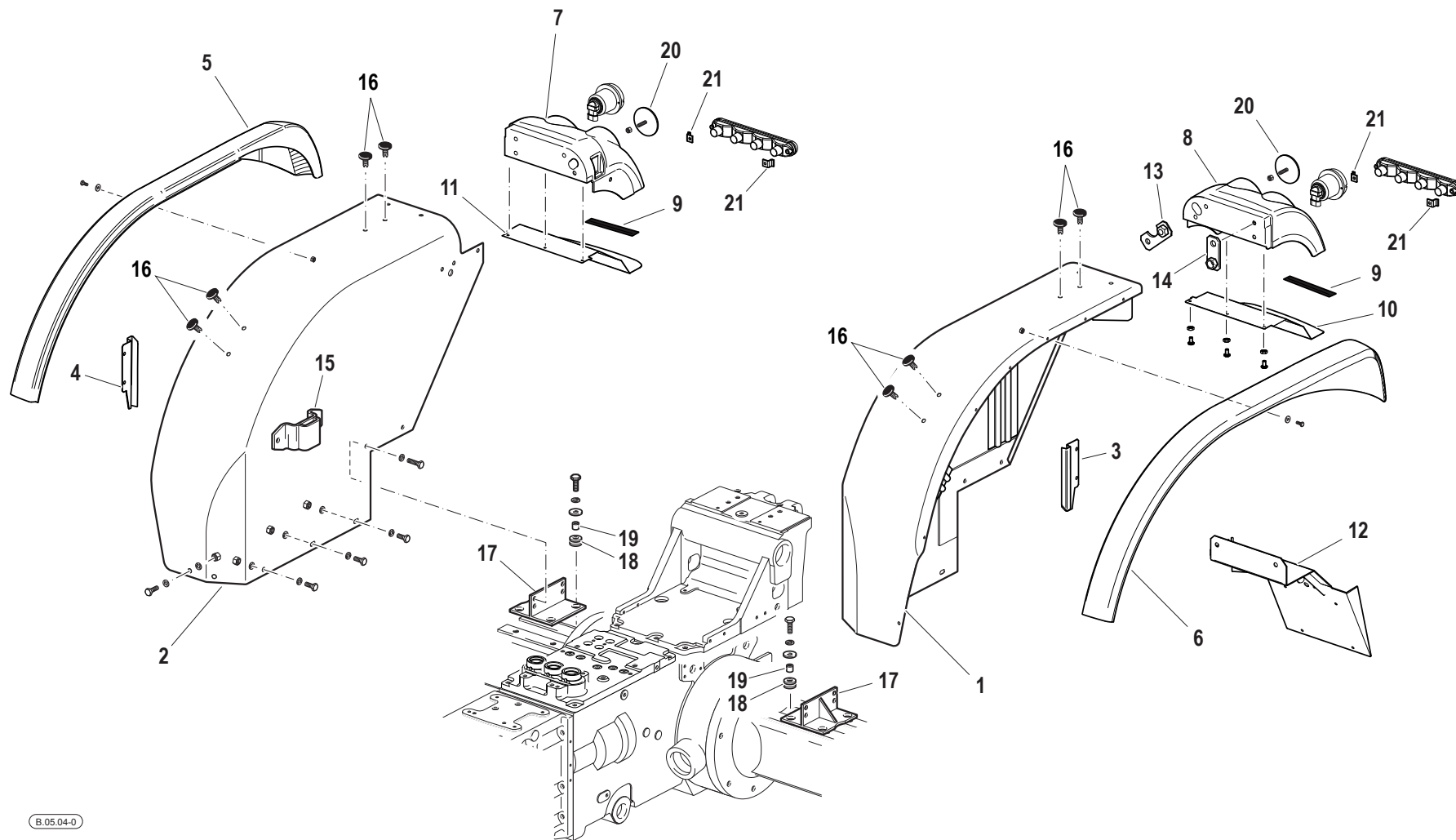
**REAR MUDGUARDS (VERSION WITH CAB)**



Pos.	Code	Q.ty	Description	Notes
1	59077445V	1	LEFT REAR FENDER	
2	59077449V	1	RIGHT REAR FENDER	
3	56177443	1	GUARD	
4	56177444	1	GUARD	
5	57377704	1	WING EXTENSION	
6	57377707	1	WING EXTENSION	
7	57376623	1	SUPPORT	
8	57376624	1	SUPPORT	
9	F0256910010	1	CELL FOAM PROFILE 10X15	
10	56176908	1	COVER	
11	56176907	1	COVER	
12	59076780	1	LICENCE PLATE HOLD	
13	56177264	1	RETAINING PLATE	
14	56177265	1	RETAINING PLATE	
15	59070592	1	LEVER BEARING	
16	30040095	8	PLUG D.8,5/14	
17	59077474	2	FIXING BRACKET	
18	55175174	8	BLOCK	
19	56171954	8	SPACER	
20	58177330	2	REFLECTOR	
21	56177045	8	RETAINER	

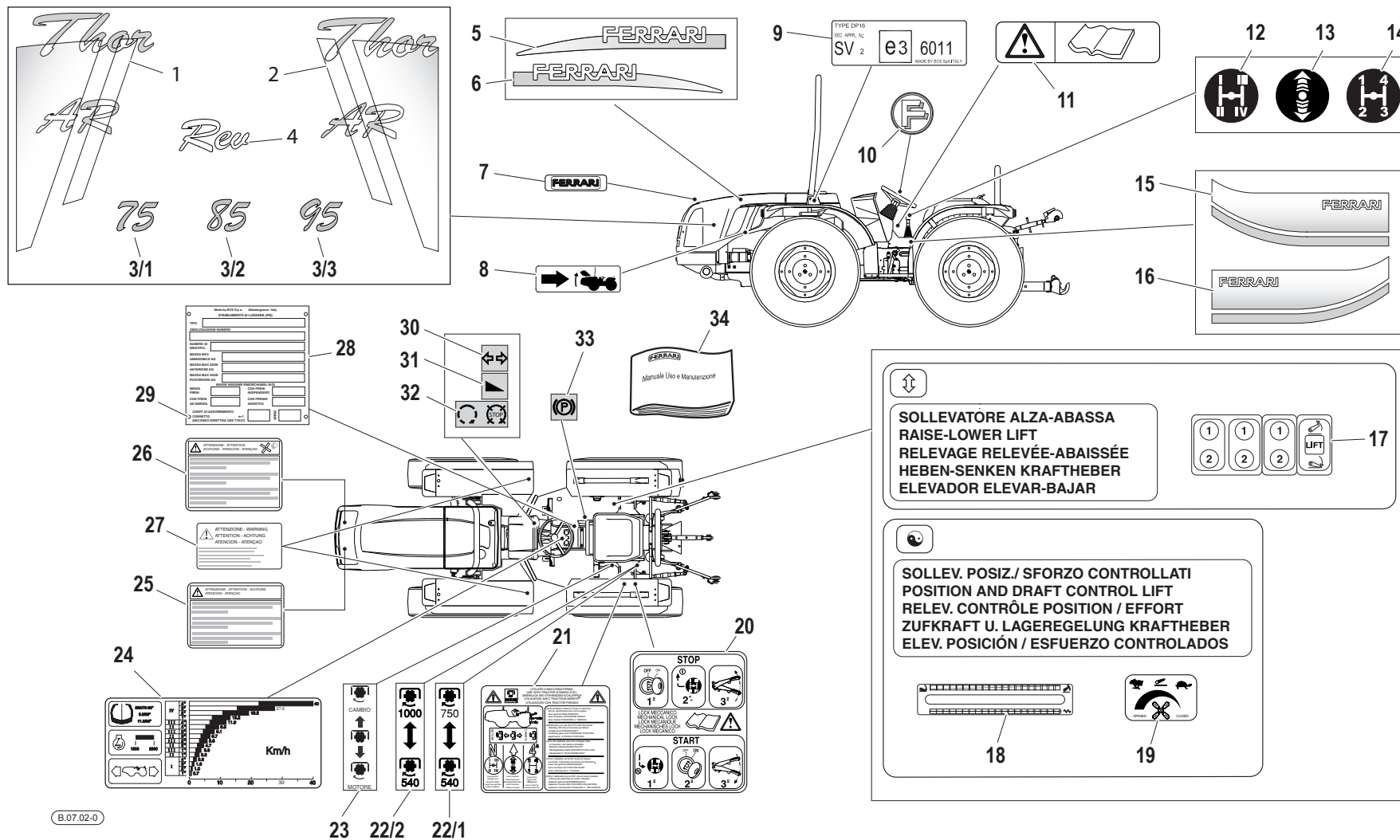

Pos.	Code	Q.ty	Description	Notes
1	58074792	1	DECAL	
2	58074793	1	DECAL	
3/1	58077581	2	DECAL	
3/2	58077580	2	DECAL	
3/3	58077579	2	DECAL	
4	58074791	2	DECAL	
5	58074786	1	DECAL	
6	58074787	1	DECAL	
7	58079466	1	DECAL	
8	58074841	1	DECAL	
9	58077615	1	PLATE	
10	58074777	1	DECAL	
11	58074880	1	PLATE	
12	58074221	1	DECAL	
13	58074220	1	DECAL	
14	58074222	1	DECAL	
15	58074839	1	DECAL	
16	58074846	1	DECAL	
17	58075022	1	PLATE	
18	58075153	1	DECAL	
19	58075250	1	DECAL	
20	58075021	1	DECAL	
21	58076077	1	DECAL	
22/1	58072518	1	PLATE	
22/2	58072574	1	PLATE	
23	58072575	1	PLATE	
24	58077654	1	PLATE	
25	58173772	1	PLATE	
26	58173773	1	PLATE	
27	58073156	2	PLATE	
28	58072737	1	PLATE	
29	F0808518050	4	RIVET 3,5x6,5	
30	58072509	1	INSTRUCTION PLATE	
31	58072517	1	INSTRUCTION PLATE	

SERIAL

**PLATES AND STICKERS**

CODE REV

**B.07.02\_0\_42592**

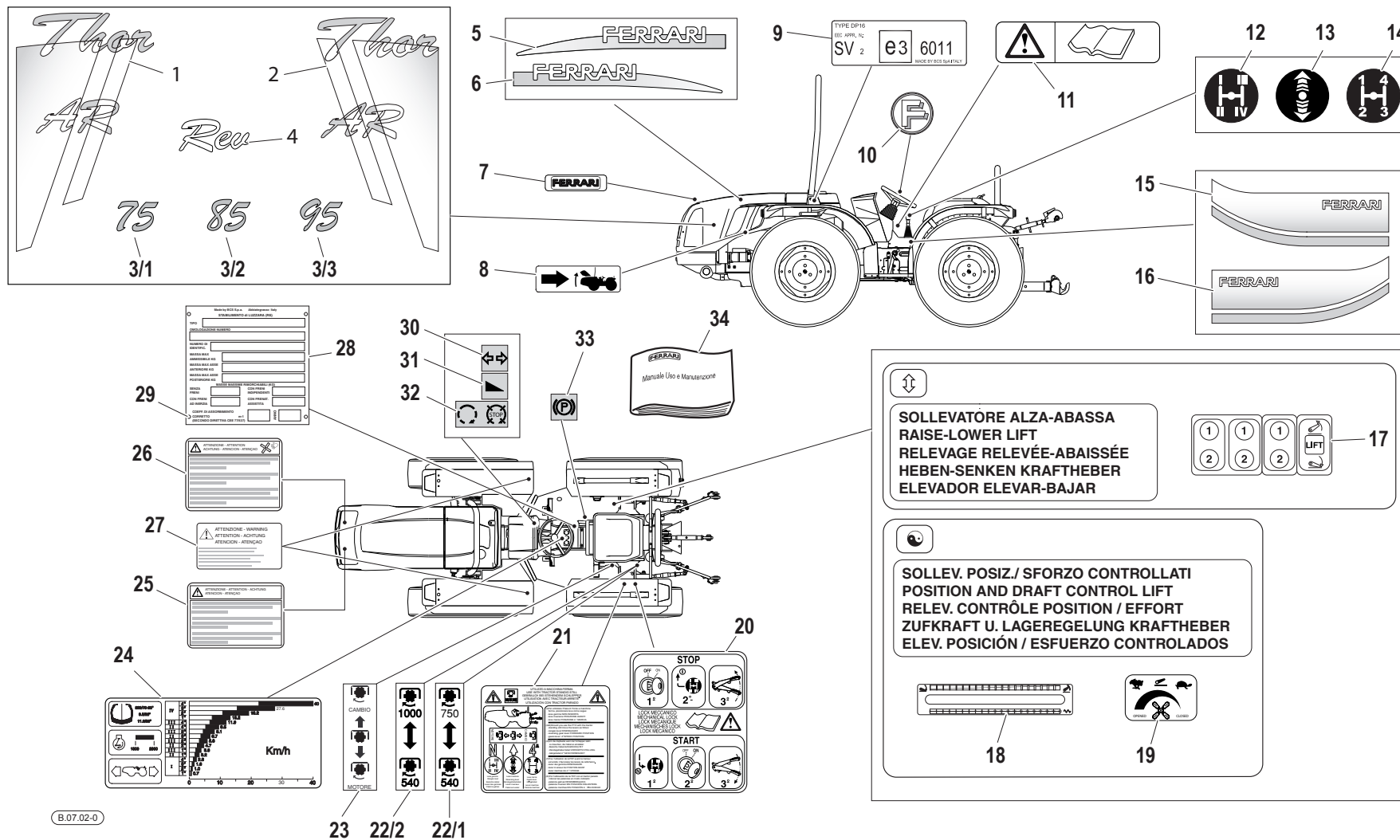

<b>Pos.</b>	<b>Code</b>	<b>Q.ty</b>	<b>Description</b>	<b>Notes</b>
32	58072511	1	INSTRUCTION PLATE	
33	58072510	1	INSTRUCTION PLATE	
34	F0907170150	1	TECHN. MANUAL THOR	

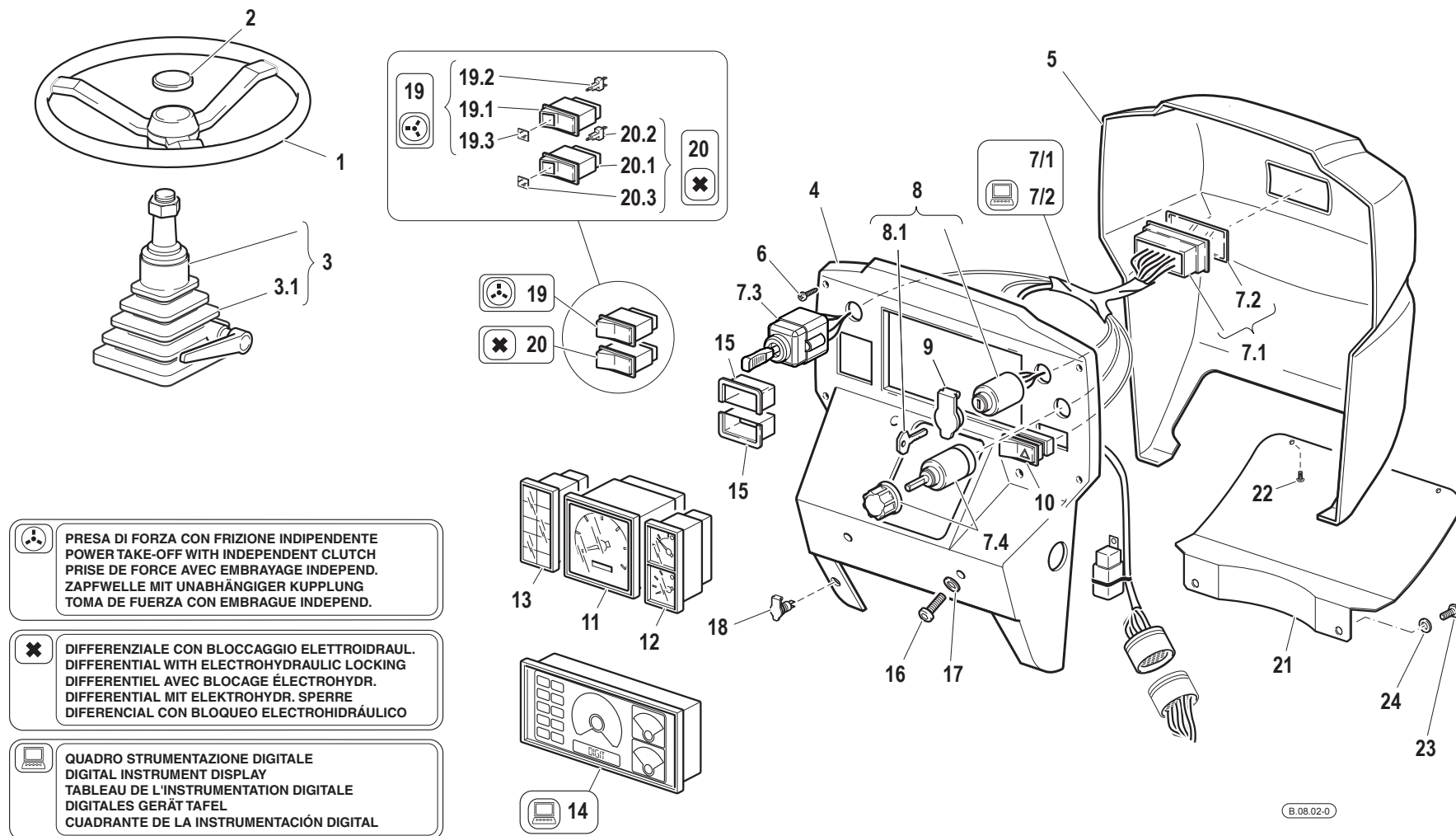

Pos.	Code	Q.ty	Description	Notes
1	F0865040000	1	STEERING WHEEL	
2	F0865040020	1	PLUG	
3	F0865474000	1	UNIT	
3.1	F0865474005	1	BELLOWS	
4	55274441	1	INSTRUMENT PANEL	
5	55271644	1	INSTRUMENT PANEL	
6	31510053	6	RIBBED SCREW TC 4,8X32	
7/1	58077601	1	CABLE	
7.1	58170453	1	FUSE BOX	
7.2	58172267	1	COVER	
7/2	58077602	1	CABLE	
7.3	F0825436000	1	SWITCH	
7.4	F0825436003	1	SWITCH	
8	30000614	1	PANEL	
8.1	F0825500220	1	KEY	
9	F0825400060	1	COVER	
10	F0825115010	1	PUSH-BUTTON	
11	58177867	1	TRACTOR METER	
12	58175769	1	DIGITAL INSTRUMENT	
13	58175770	1	WARNING LIGHT HOLDER	
14	58174928	1	INSTRUMENT	
15	58170376	2	TERMINAL FOR SWITCH	
16	F0862479020	4	SCREW M8X16 7380	
17	31411084	4	WASHER 8,4x17	
18	F0825403050	1	SOCKET	
19	58170344	1	CHANGE-OVER SWITCH	
19.1	58173116	2	CHANGE-OVER SWITCH	
19.2	58173119	2	PILOT LIGHT 12V	
19.3	58173120	1	GLASS	
20	58170345	1	CHANGE-OVER SWITCH	
20.1	58173116	2	CHANGE-OVER SWITCH	
20.2	58173119	2	PILOT LIGHT 12V	
20.3	58173121	1	GLASS	
21	57374553	1	COVER	

SERIAL

**DASHBOARD**

CODE REV

**B.08.02\_0\_38771**

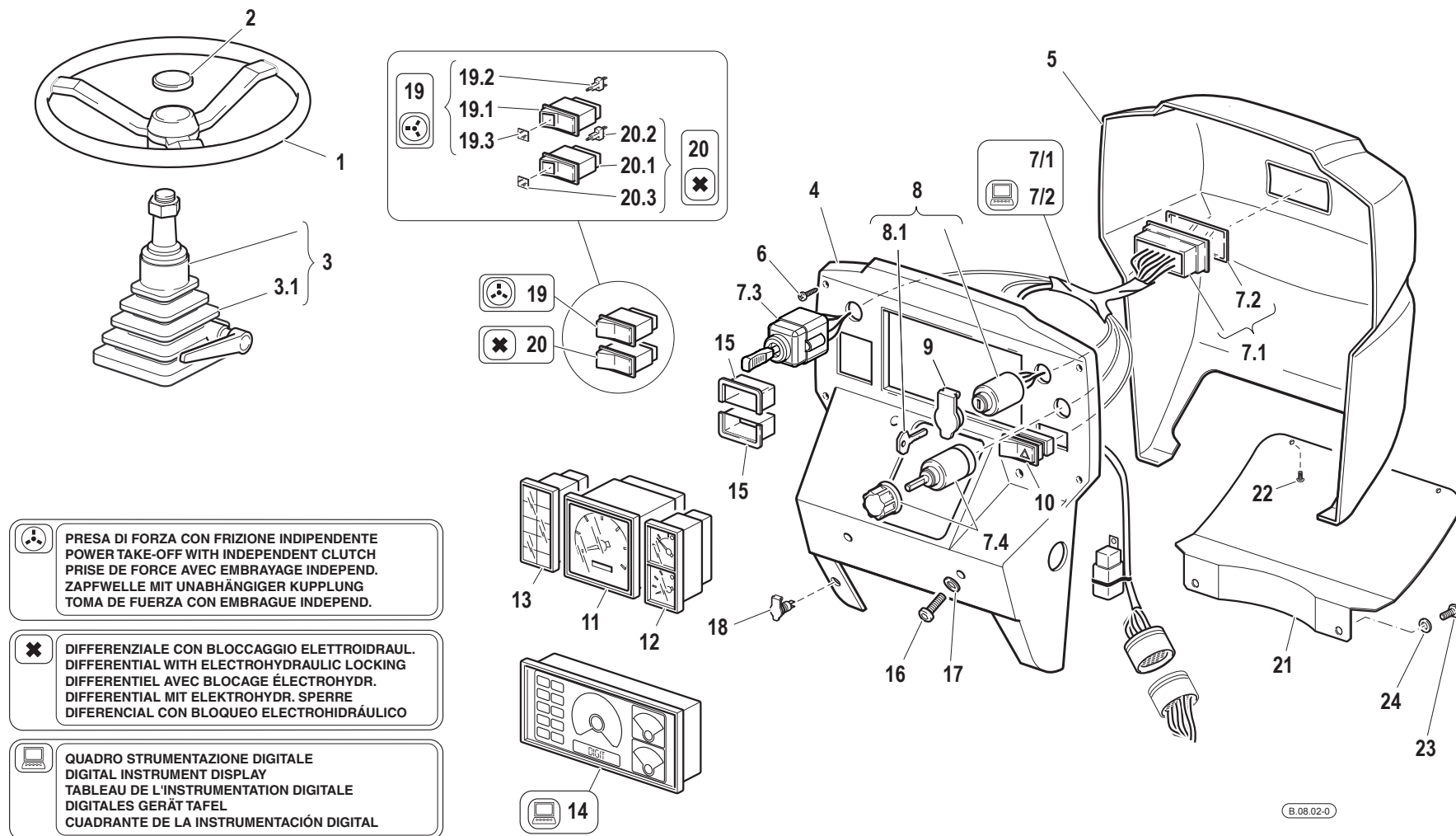



<b>Pos.</b>	<b>Code</b>	<b>Q.ty</b>	<b>Description</b>	<b>Notes</b>
22	F0861867001	3	SCREW M4,2X16 DIN 7981	
23	31112149	2	SCREW TE M8X12 UNI 5739 8G	
24	31411084	2	WASHER 8,4x17	

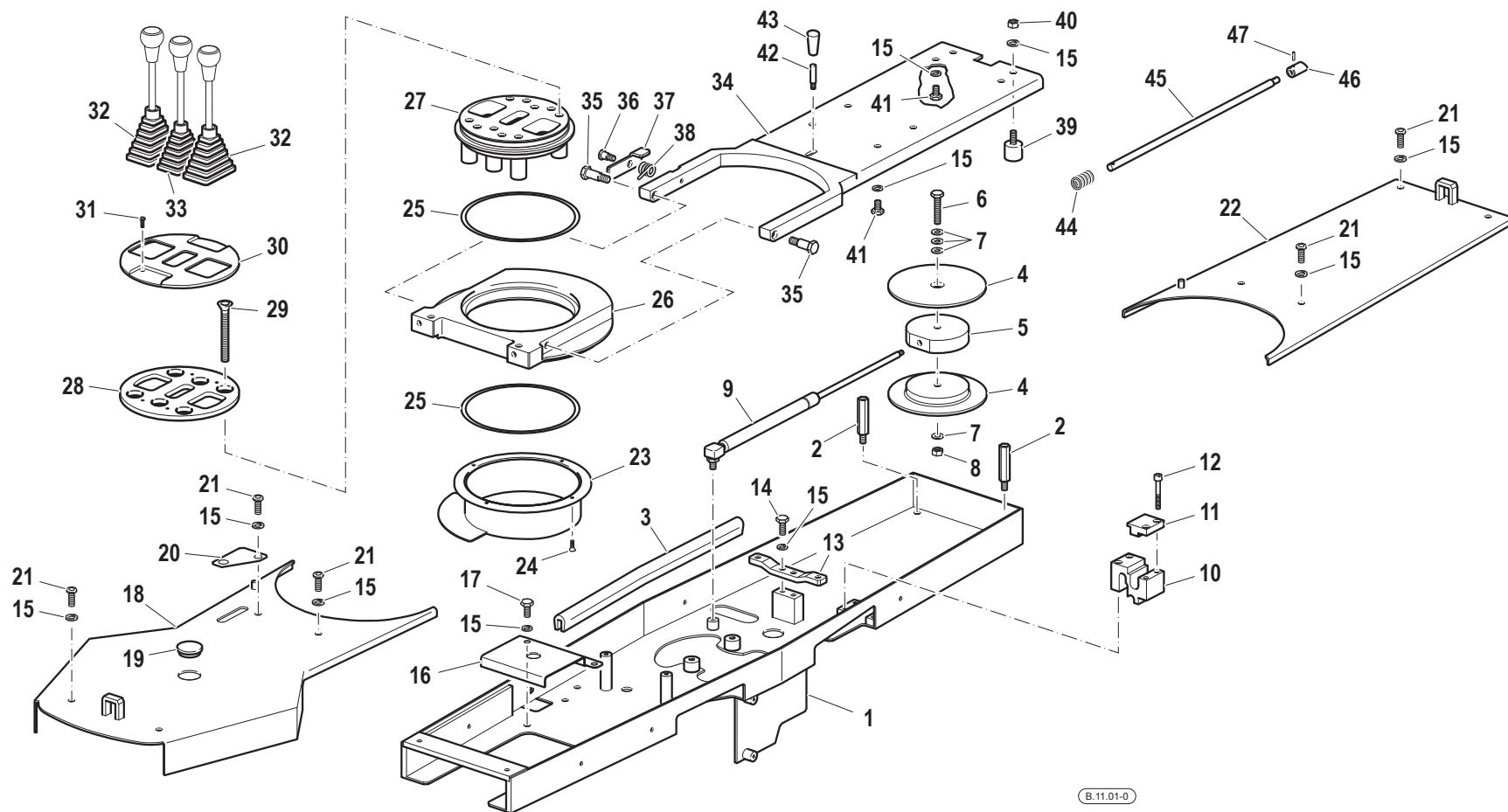

Pos.	Code	Q.ty	Description	Notes
1	59074468	1	BOX	
2	56174492	2	PIN	
3	F0256809010	1	GASKET	
4	57374490	2	PULLEY	
5	57374491	1	PULLEY	
6	F0862875000	1	SCREW M8X1,25/45 UNI5739	
7	31411084	4	WASHER 8,4x17	
8	F0814585000	1	SELFLOCK NUT	
9	58174555	1	SPRING	
10	56174464	1	SMALL BLOCK	
11	56174773	1	COVER	
12	31152066	4	SCREW TCEI M6X45 UNI 5931	
13	56174486	1	RETAINER	
14	31112146	2	SCREW TE M8X22 UNI 5739 8G	
15	F0843643060	16	WASHER 8	
16	56174489	1	PLATE	
17	31112147	2	SCREW TE M8X18 UNI 5739 8G	
18	59074476V	1	COP.ANT.SC.TUB(59074476)VERDE	
19	F0852516020	1	CABLE GLAND	
20	56174499	1	COVER	
21	59074477V	1	COP.POST.C.TUBI(74477)VERDE	
21	F0862479020	8	SCREW M8X16 7380	
23	59074403	1	FLANGE	
24	31132440	4	SCREW TSVEI M4X10 UNI 5933	
25	57374545	2	GASKET	
26	51174524V	1	ROTATING TOWER (74524)GREEN **	
27	51274388	1	SUPPORT	
28	51274498	1	FLANGE	
29	F0863586000	6	SCREW M10X80 DIN 7991	
30	57374501	1	COVER	
31	F0861928050	4	SCREW M5X12 ISO 7380	
32	55174163	2	BELLOWS	
33	55174162	1	BELLOWS	
34	59074525V	1	SUPP.SEDILE(59074525F)VERDE	

SERIAL

**SEAT SUPPORT / GEAR LEVERS COVER**

CODE REV

**B.11.01\_0\_38871**

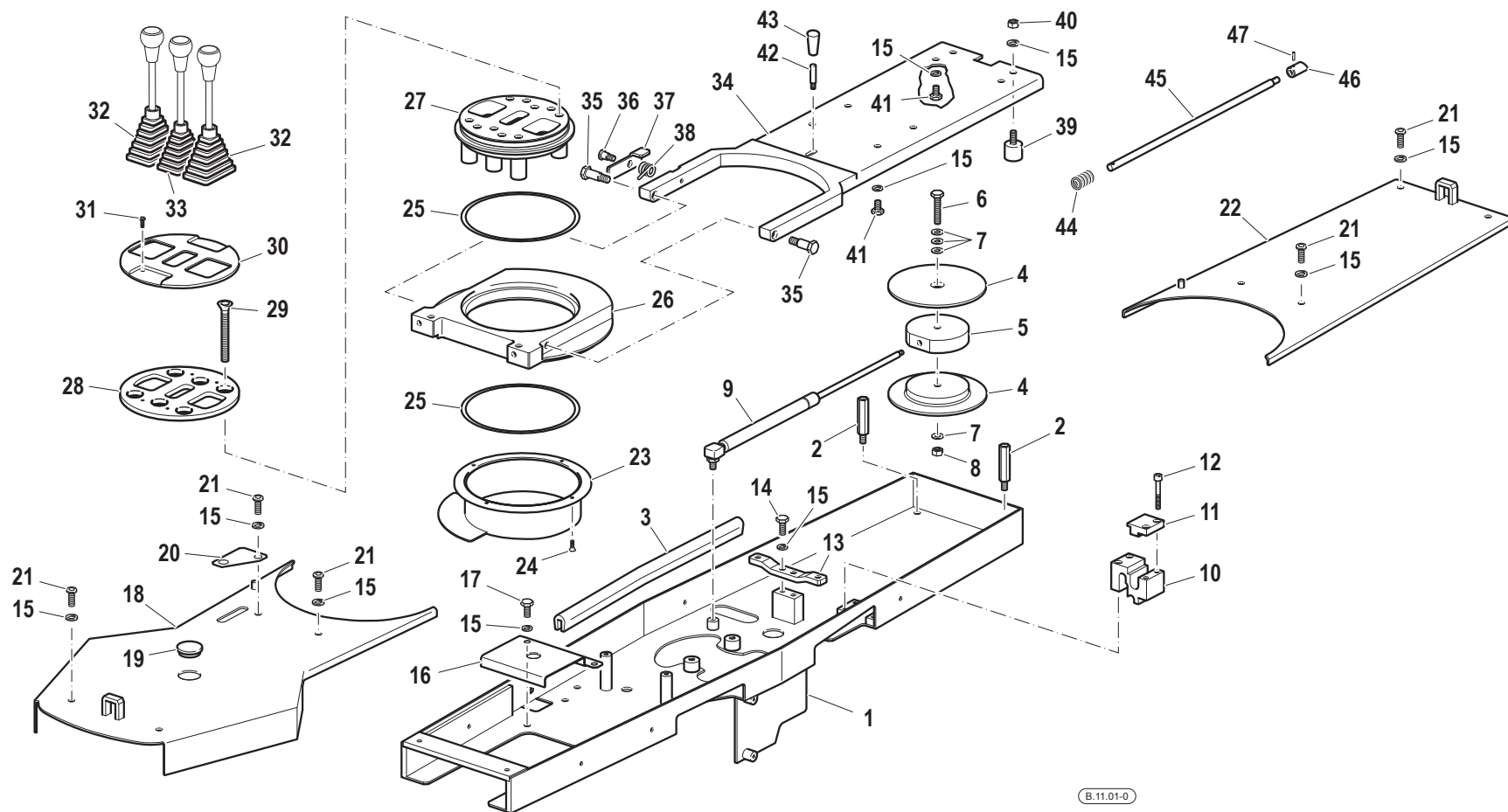

Pos.	Code	Q.ty	Description	Notes
35	56274487	2	SPECIAL SCREW	
36	56375436	1	HINGE PIN	
37	56174462	1	RETAINING PLATE	
38	58074488	1	SPRING	
39	58174644	2	SILENT-BLOCK	
40	31211080	2	NUT M8	
41	31111151	4	SCREW TE M8X16 UNI 5739 8G	
42	56174461	1	PIN	
43	F0837521000	1	GRIP	
44	58070390	1	SEAT SPRINGS	
45	56174463	1	ROD	
46	56374460	1	LOCKING BOLT	
47	34213018	1	ROLL PIN	

SEAT (STANDARD)

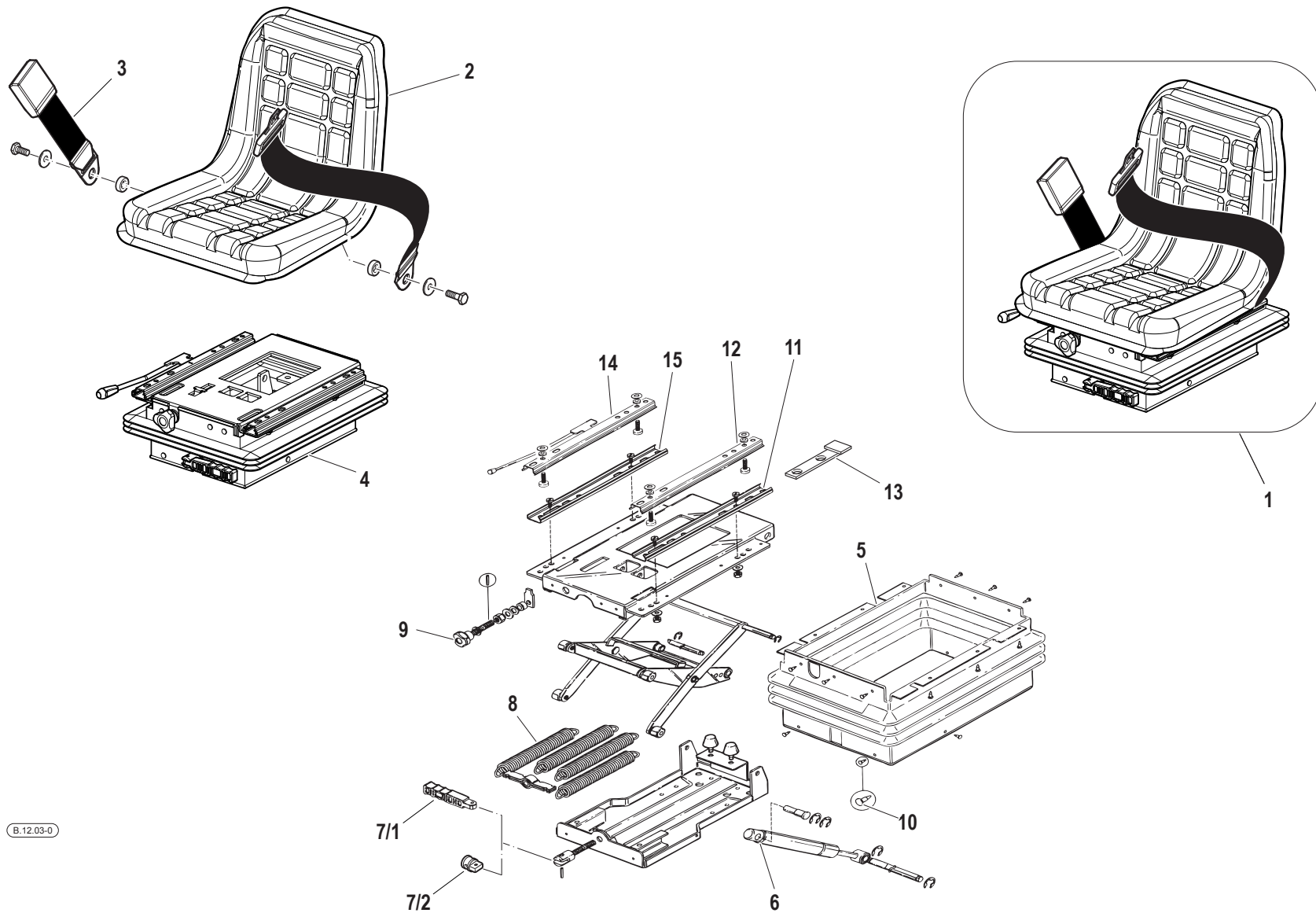

Pos.	Code	Q.ty	Description	Notes
1	58177722	1	SEAT	
2	59901050	1	SEAT	
3	58192377	1	SAFETY BELT	
4	59901049	1	SUSPENSION	
5	59900159	1	BELLOWS	
6	59900156	1	SHOCKS ABSORBER	
7/1	59900155	1	LEVER	
7/2	56172172	1	SMALL BLOCK	
8	59900154	4	SPRING	
9	59900153	1	KNOB	
10	59900157	1	LOWER GUIDE	
10	59900158	18	SCREW	
12	59900160	1	GUIDE	
13	59071241	1	STOP PLATE	
14	59900161	1	GUIDE	
15	59900152	1	LOWER GUIDE	

◇  
 VERSIONE CON CABINA  
 VERSION WITH CAB  
 VERSION AVEC LA CABINE  
 VERSION MIT KABINE  
 VERSIÓN CON LA CABINA

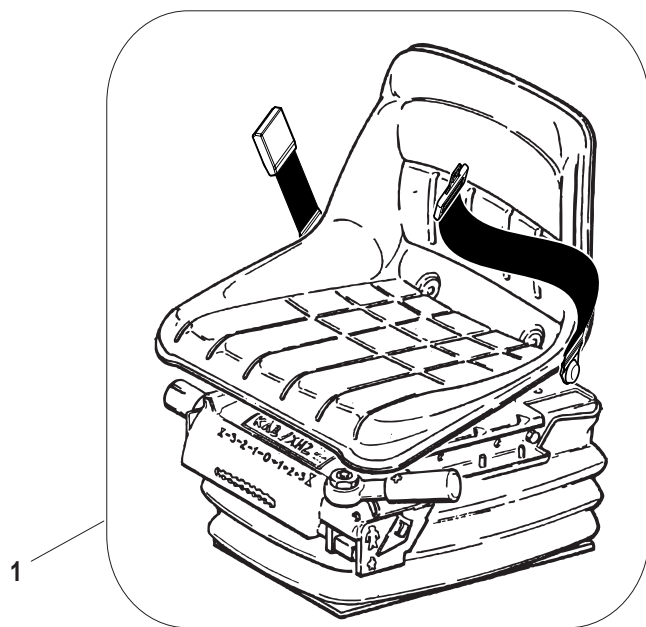

B.12.02-0

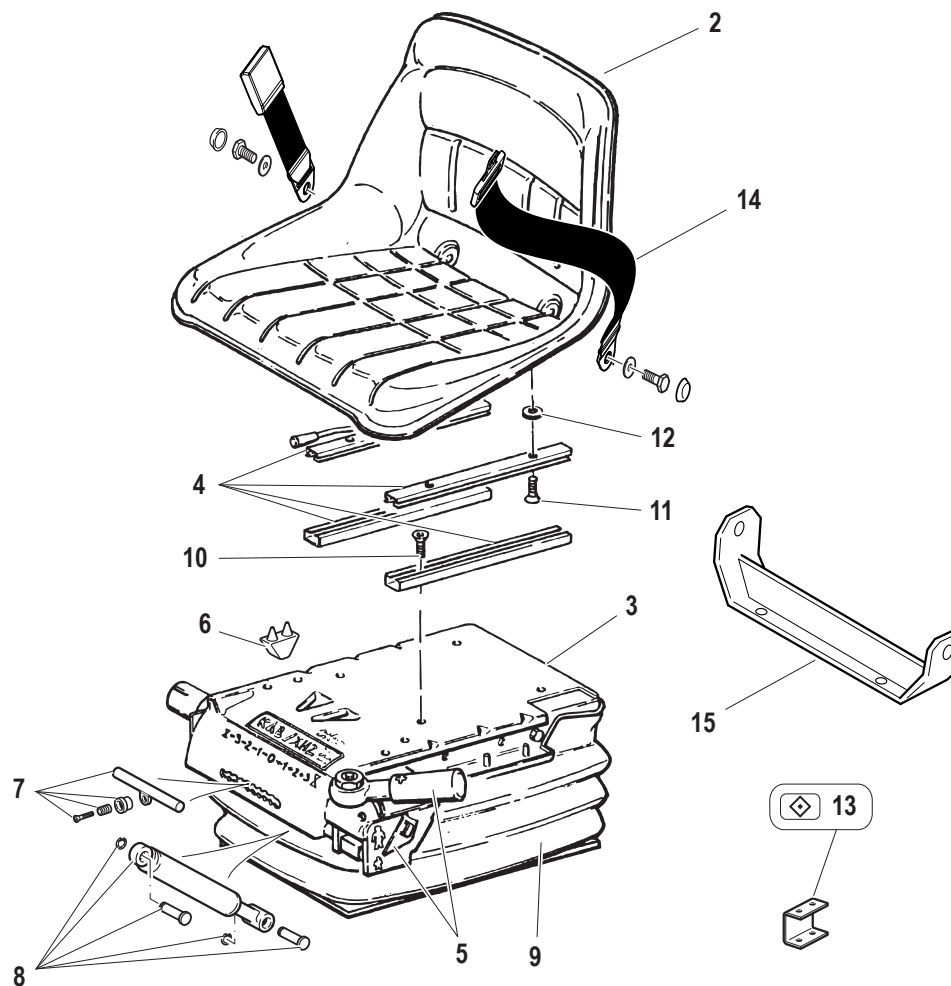



Pos.	Code	Q.ty	Description	Notes
1	59900199	1	SEAT	
2	F0150036216	1	SEAT CAVITY	
3	F0150036219	1	SPRING	
4	58173437	1	SEAT GUIDE	
5	59900183	1	CONTROL	
6	59900184	1	LIMITER	
7	59900185	1	CONTROL	
8	59900186	1	SHOCKS ABSORBER	
9	59900187	1	BELLOWS	
10	31111151	5	SCREW TE M8X16 UNI 5739 8G	
11	F0862495010	4	SCREW	
12	F0843696000	6	WASHER	
13	56171223	1	BRACKET	
14	58192377	1	SAFETY BELT	
15	56178591	1	BRACKET	

**QUADRO STRUMENTAZIONE DIGITALE**  
**DIGITAL INSTRUMENT DISPLAY**  
**TABLEAU DE L'INSTRUMENTATION DIGITALE**  
**DIGITALES GERÄT TAFEL**  
**CUADRANTE DE LA INSTRUMENTACIÓN DIGITAL**

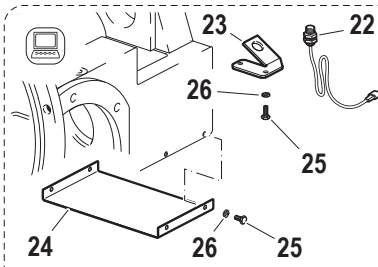

**VEDI ANCHE ...**  
**SEE ALSO ...**  
**VOIR AUSSI ...**  
**SIEHE AUCH ...**  
**VER TAMBIEN ...**

**D.01.02**

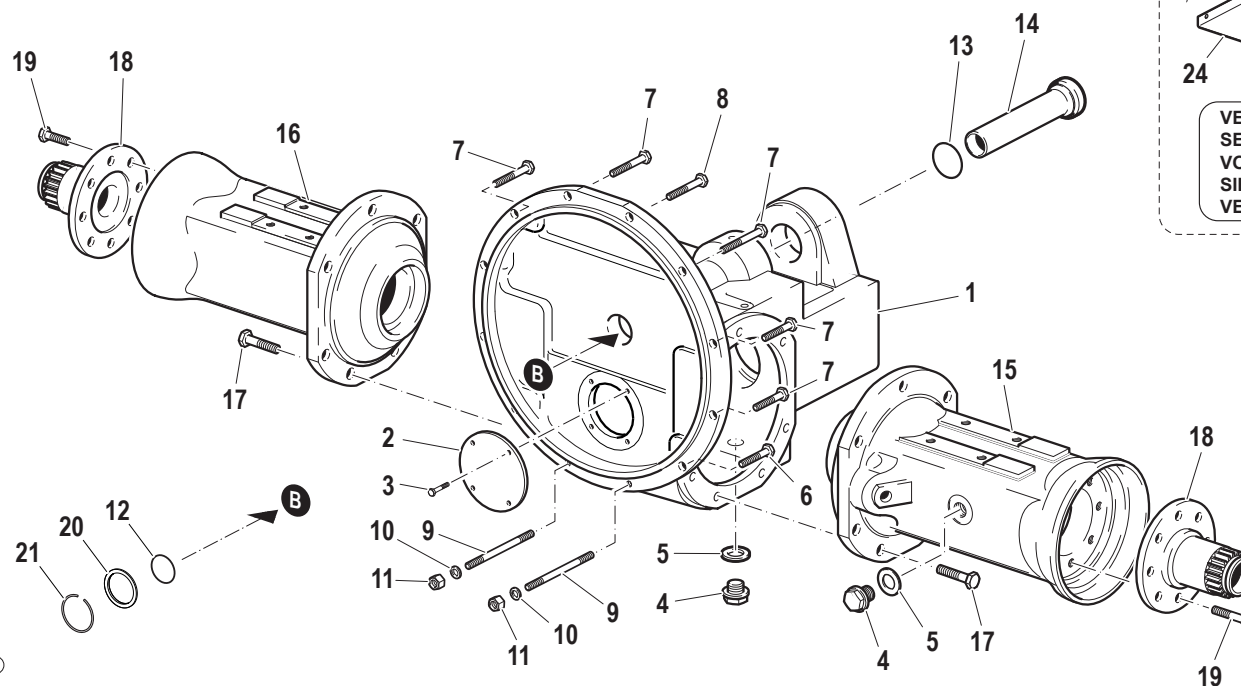

Pos.	Code	Q.ty	Description	Notes
1	51176126	1	FRONT AXLE HOUSING	
2	51176125	1	FRONT COVER	
3	31112090	4	SCREW TE M6X16 UNI 5739 8G	
4	56370081	2	PLUG	
5	F0844273090	2	GASKET 22X28X1,5 CU 99,5	
6	31112211	2	SCREW TE M10X30 UNI 5739	
7	31112212	7	SCREW TE M10X35 UNI 5739	
8	31112213	1	SCREW TE M10X40 UNI 5739	
9	F0838475000	2	STUD BOLT M10X90 UNI 5911 8.8	
10	F0814632000	2	NUT M10	
11	F0843755000	12	WASHER 10	
12	F0803259000	1	O-RING	
13	F0803209070	1	O-RING	
14	59070012	1	PIPE	
15	51173806	1	FRONT AXLE HOUSING	
16	51173805	1	FRONT AXLE HOUSING	
17	F0864222010	16	SCREW M14X1,5/40 5738	
18	56373800	2	SUPPORT	
19	F0863890010	16	SCREW M12x1,75x35	
20	56177068	1	SPACER	
21	F0801310600	1	SAFETY RING	
22	58175209	1	SENSOR	
23	56174919	1	BRACKET	
24	56172538	1	LAMINATION	
25	31112082	8	SCREW TE M6X12 UNI 5739 8G	
26	F0843570000	8	WASHER 6	

CENTRAL SECTION

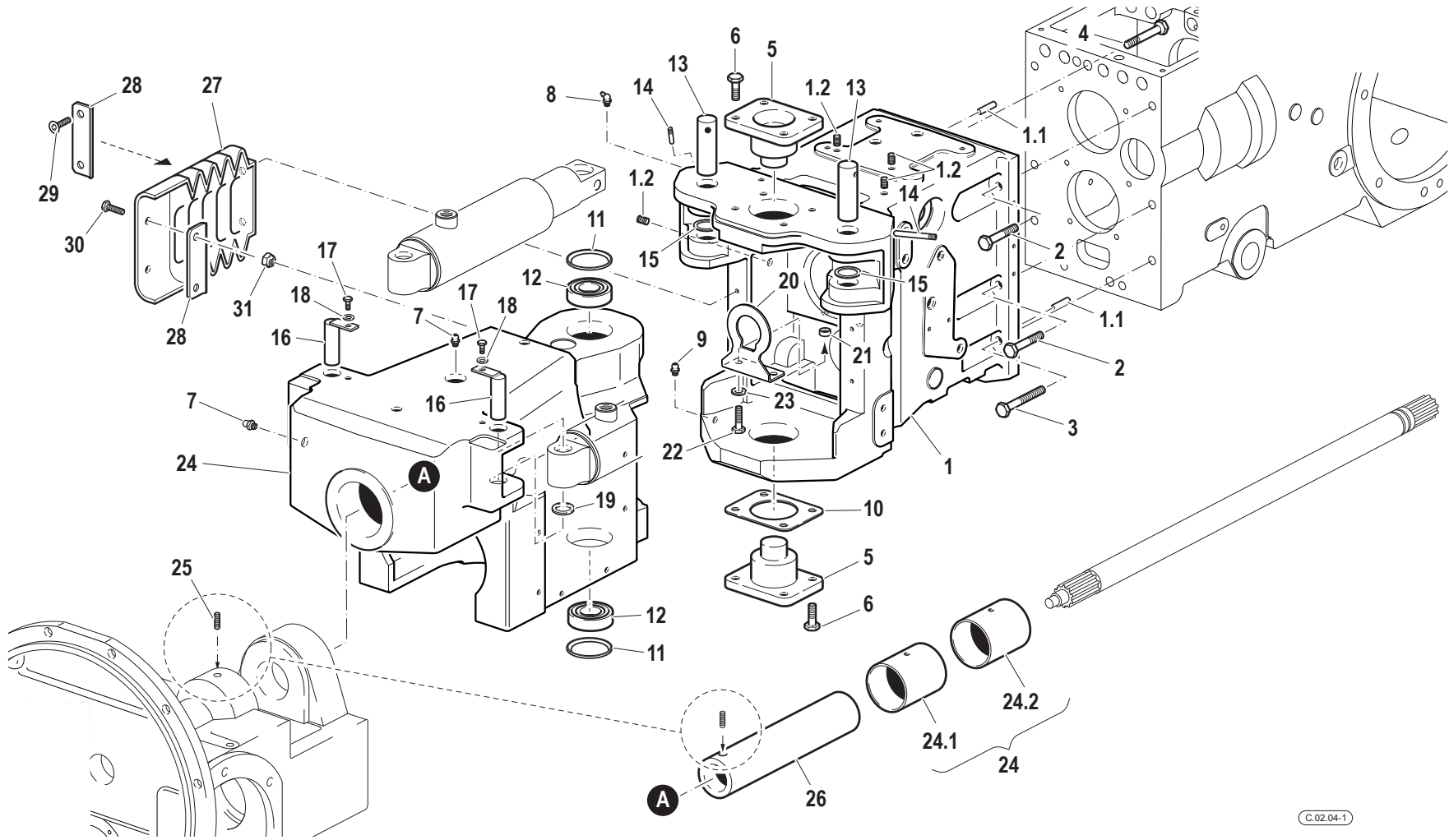

Pos.	Code	Q.ty	Description	Notes
1	59276003	1	BOX	
1.1	56570016	2	CYLINDRICAL PLUG	
1.2	58079118	1	ROD	
2	F0863925000	7	SCREW M12X40 UNI 5737	
3	F0863997010	1	SCREW M12X50 UNI 5737	
4	F0863951000	1	SCREW M12X45 UNI 5737	
5	52379209	2	JOINT PIN	
6	F0863267050	8	SCREW M10x25	
7	F0826056000	2	LUBRICATOR M10 UNI 7663A	
8	30000005	1	LUBRICATOR M10	
9	30000007	1	LUBRICATOR	
10	52173669	1	SHIM	
10	52173670	1	SHIM	
10	52173671	1	SHIM	
10	52173672	1	SHIM	
10	52173673	1	SHIM	
11	58170077	2	GASKET	
12	F0812838000	2	BEARING 32007 (35x62x18 R)	
13	56374556	2	HINGE PIN	
14	56370178	2	SCREW	
15	56374557	2	SPACER	
16	59070838	2	HINGE PIN	
17	31111151	2	SCREW TE M8X16 UNI 5739 8G	
18	F0843643060	2	WASHER 8	
19	F0844240000	2	WASHER 20,5x33/3	
20	59075813	1	BRACKET	
21	56170364	2	SPACER	
22	31112146	2	SCREW TE M8X22 UNI 5739 8G	
23	F0843643060	2	WASHER 8	
24	59276002	1	BOX	
24.1	56276372	1	BUSHING	
24.2	56276371	1	BUSHING	
25	58077226	1	GRAIN	
26	56477227	1	PIN	

SERIAL  
START  
**914705**

**CENTRAL SECTION**

CODE REV  
**C.02.04\_1\_39212**

CENTRAL SECTION

SERIAL START 914705

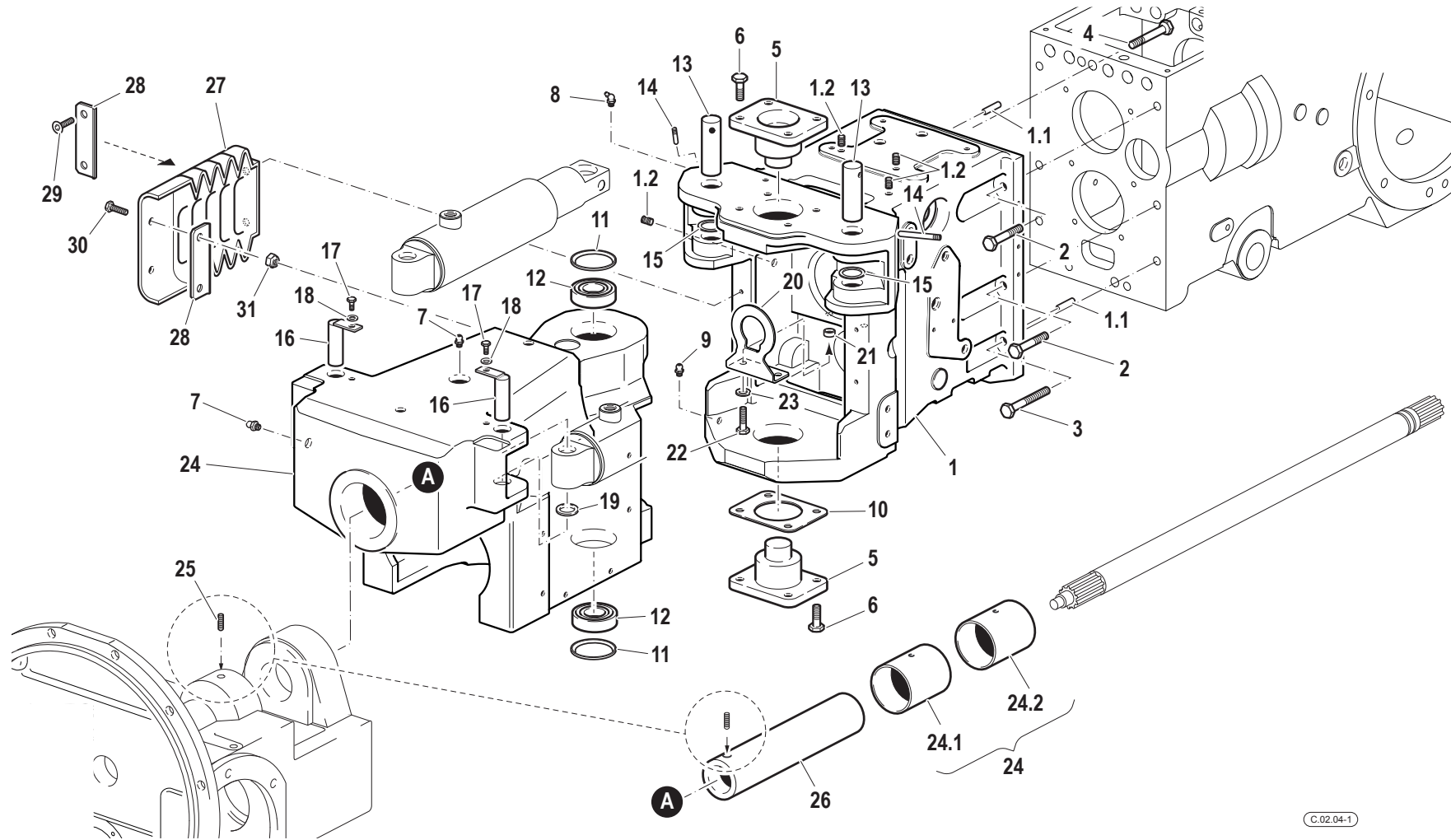

<b>Pos.</b>	<b>Code</b>	<b>Q.ty</b>	<b>Description</b>	<b>Notes</b>
27	55174429	2	BELLOWS	
28	56174446	4	FIXING BRACKET	
29	31132562	4	SCREW TSVEI M6X16 UNI 5933	
30	31112093	4	SCREW TE M6X20	
31	F0814547000	4	SELFLOCK NUT M6	

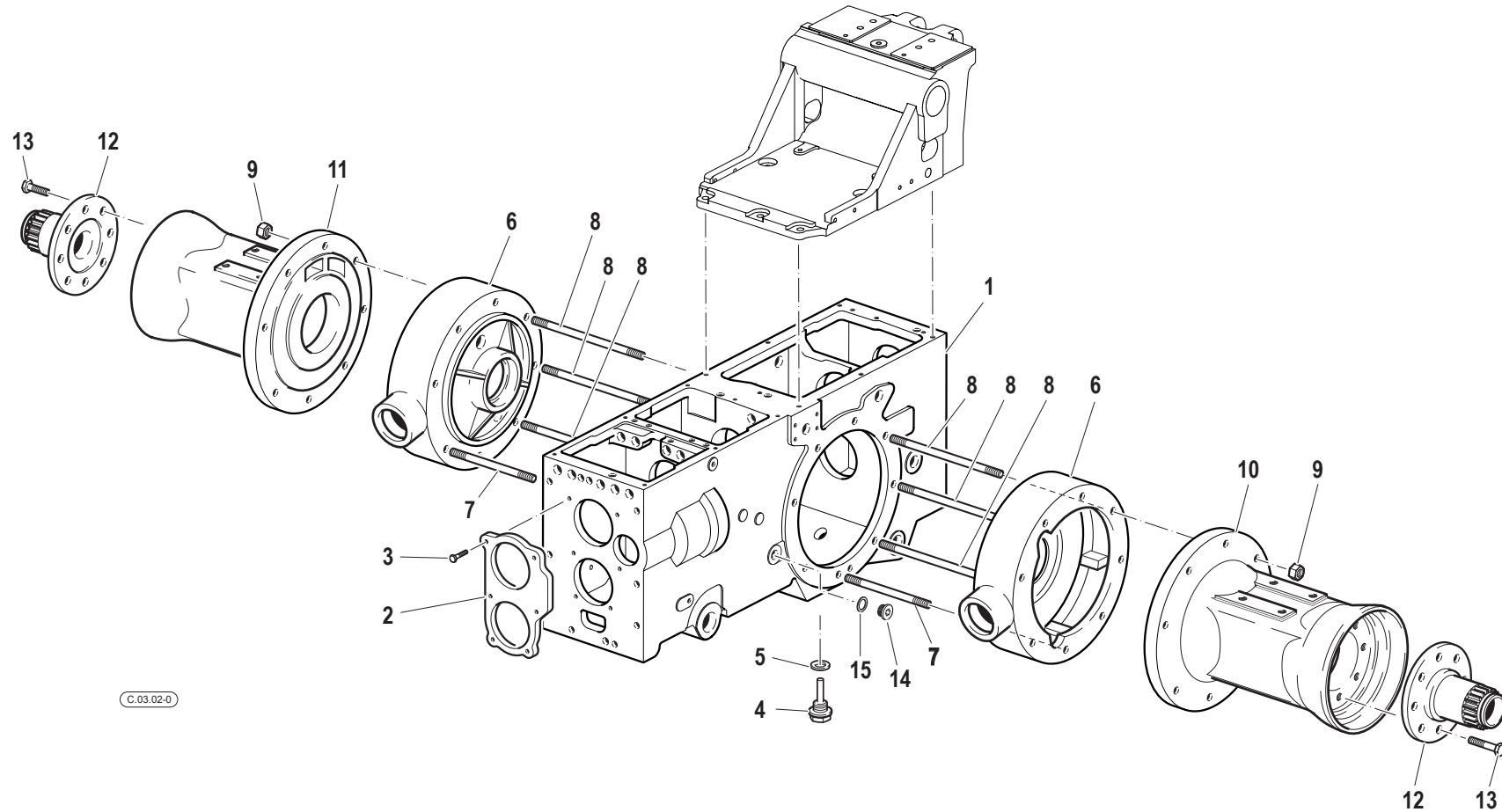



Pos.	Code	Q.ty	Description	Notes
1	51176123	1	GEAR BOX	
2	51173650	1	FRONT COVER	
3	31112151	6	SCREW TE M8X25 UNI 5739 8G	
4	58170021	1	PLUG	
5	F0844273090	1	GASKET 22X28X1,5 CU 99,5	
6	51170020	2	BRAKE HOUSING	
7	31313300	10	STUD BOLT M14X1,5X105	
8	31313320	6	STUD BOLT M14X1,5X120	
9	F0814750010	16	NUT M14X1,5	
10	51176033	1	REAR AXLE HOUSING	
11	51176034	1	REAR AXLE HOUSING	
12	56373800	2	SUPPORT	
13	F0863890010	16	SCREW M12x1,75x35	
14	30040035	1	PLUG M18x1,5 DIN908	
15	F0824113000	1	COPPER WASHER 18X24/1,5	



Pos.	Code	Q.ty	Description	Notes
1/1	58178873	1	JOINT	
1/2	58178811	1	JOINT	
2/1	F0862785000	1	SCREW	
2/2	311111156	1	SCREW TE M8X50 UNI 5737 CL 10.9	
3	56372536	1	RING NUT	
4	56470215	1	SPACER	
5	F0803078100	1	O-RING	
6	56170214	1	PROTECTIVE RING D=72	
7	F0802239045	1	SEAL 50x72x8	
8	56170213	1	SPACER	
9	F0812859000	2	BEARING 32207	
10	F0801422010	2	SEEGER RING	
11	56370209	1	SHIM	
11	56370210	1	SHIM	
11	56370211	1	SHIM	
11	56370212	1	SHIM	
12	59376519	1	BEVEL GEAR	
13	F0863311250	8	SCREW M10x1,5x32	
14	F0812956000	2	BEARING 32010 X/Q	
15	56370089	1	RING	
15	56370127	1	RING	
15	56370128	1	RING	
16	52470062	1	PINION	
17	52470061	1	PINION	
18	56471036	1	PIN	
19	56371037	1	PIN	
20	52470067	2	DIFFERENTIAL PINION	
21	51371035	1	HOUSING	
22	59070065	1	SLEEVE	
23	56470813	2	AXLE SHAFT	
24	F0851044000	3	PIN 3,0X26 DIN 1481 CL:C72	

SERIAL

**FRONT TRANSMISSION**

CODE REV

**D.01.02\_0\_40152**

# CLUTCH FRONT SHAFT/ TRANSMISSION CLUTCH

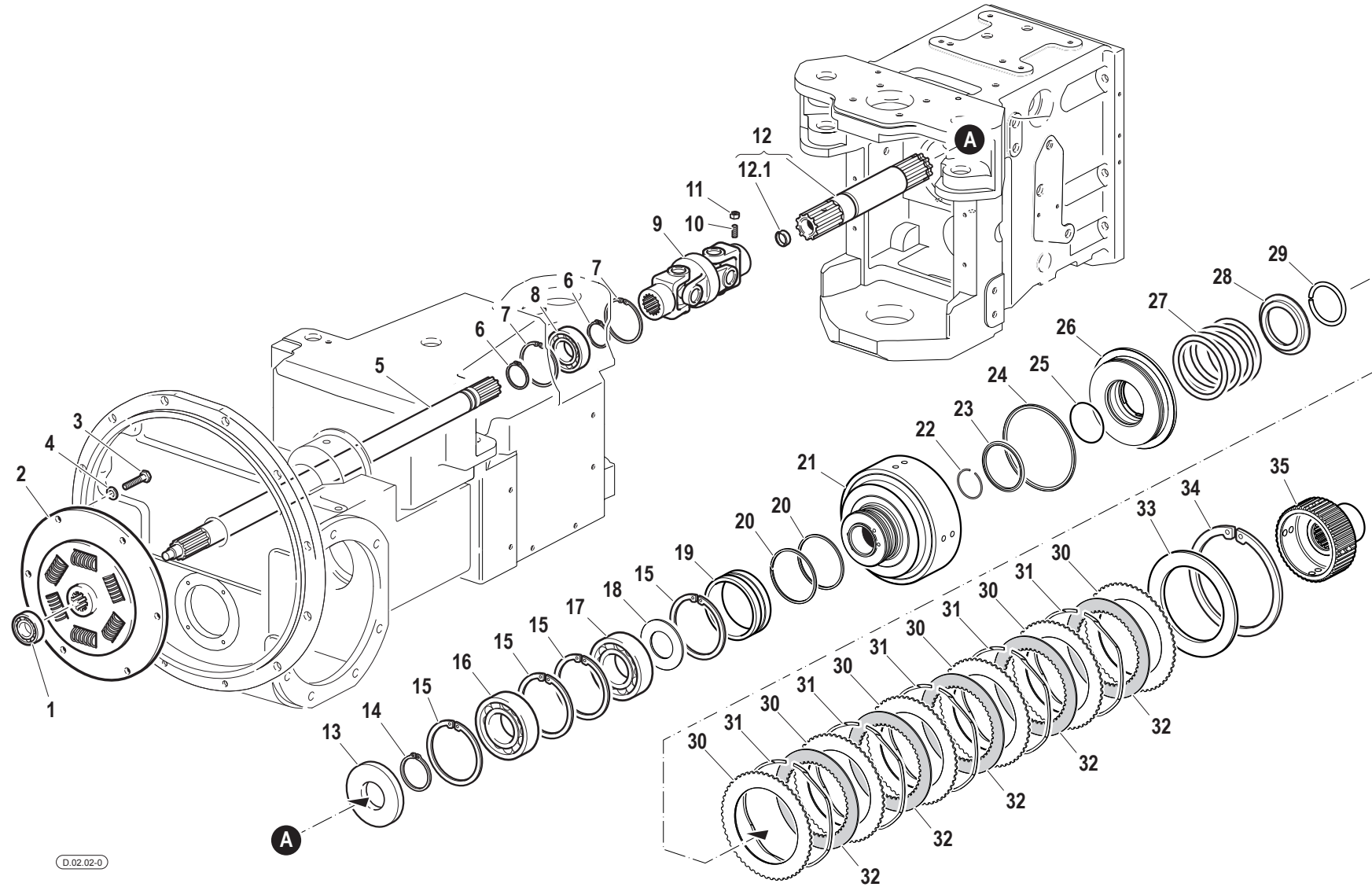

Pos.	Code	Q.ty	Description	Notes
1	F0812523050	1	BEARING 6201-2RS	
2	58177653	1	JOINT	
3	31112150	6	SCREW TE M8X20 UNI 5739 8G	
4	31421083	6	WASHER	
5	56573661	1	FRONT CLUTCH SHAFT	
6	35121030	2	SEEGER RING	
7	35111062	2	SEEGER RING	
8	37112302	1	BEARING	
9	58173664	1	CARDAN JOINT	
10	F0862657000	1	GRAIN	
11	31211080	1	NUT M8	
12	52473660	1	SHAFT	
12.1	58073461	1	PLUG	
13	F0802163010	1	SEAL 35x80/10	
14	F0801264050	1	SEEGER RING	
15	35111080	4	SEEGER RING	
16	37111354	1	BEARING	
17	F0812868100	1	BEARING 6307-2Z (35x80x21)	
18	56371162	1	SHIM	
19	56470002	1	BUSHING	
20	58170306	2	SEAL	
21	52573648	1	CLUTCH HOUSING	
22	F0801266100	1	SAFETY RING	
23	58170443	1	GASKET	
24	58172400	1	GASKET	
25	38104412	1	O-RING	
26	53273025	1	PISTON	
27	58070262	1	RESTORING SPRING	
28	56370267	1	RING	
29	58070268	1	CIRCLIP	
30	58170034	6	DISC	
31	58172106	5	SPRING	
32	58172105	5	DISC	
33	56370037	1	CLUTCH DISC	

SERIAL

**CLUTCH FRONT SHAFT/ TRANSMISSION CLUTCH**

CODE REV

**D.02.02\_0\_39318**

# CLUTCH FRONT SHAFT/ TRANSMISSION CLUTCH

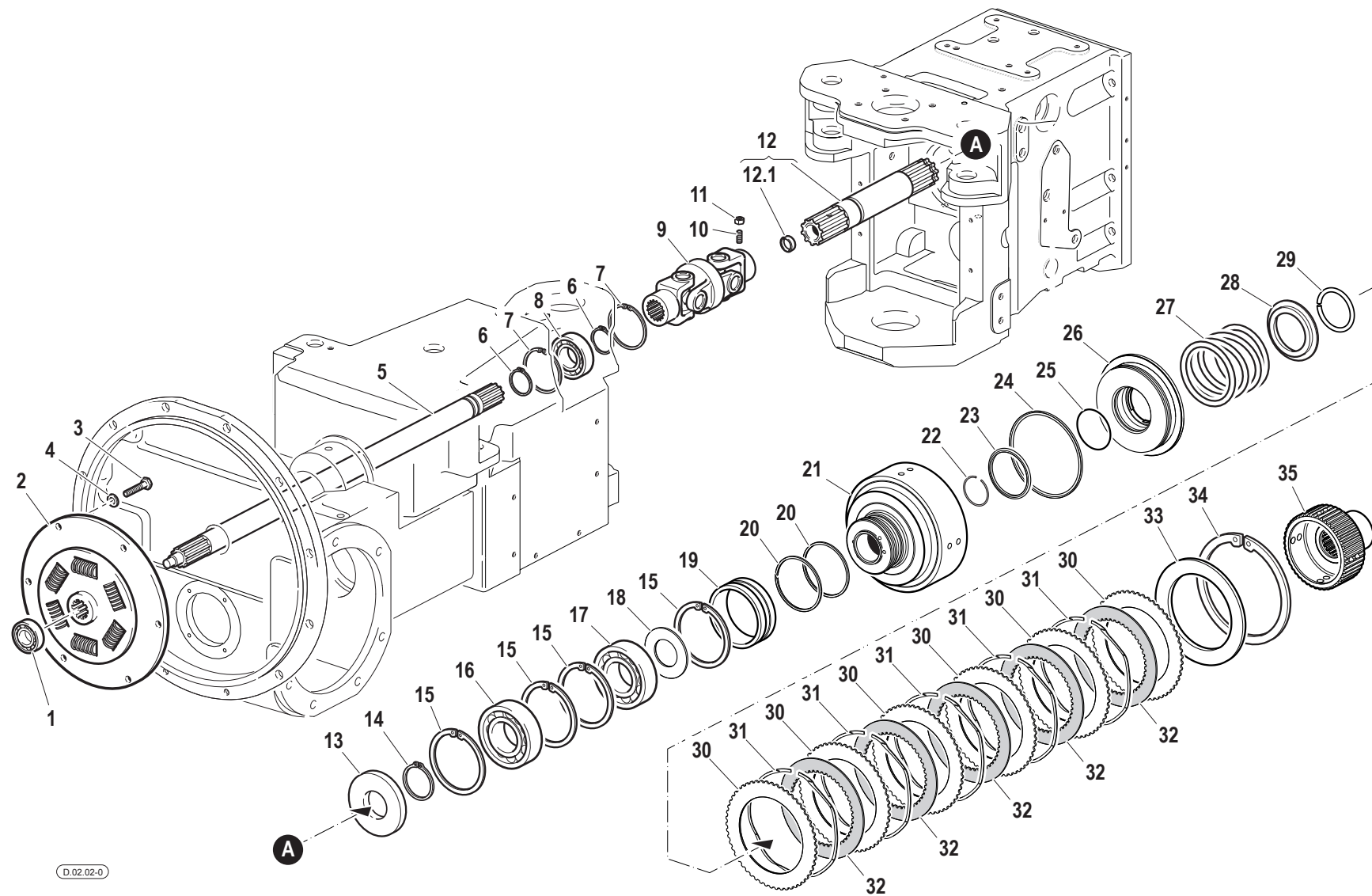

D.02.02-0

Pos.	Code	Q.ty	Description	Notes
34	F0801455100	1	SEEGER RING	
35	52473655	1	HUB	

# CLUTCH CONTROLS

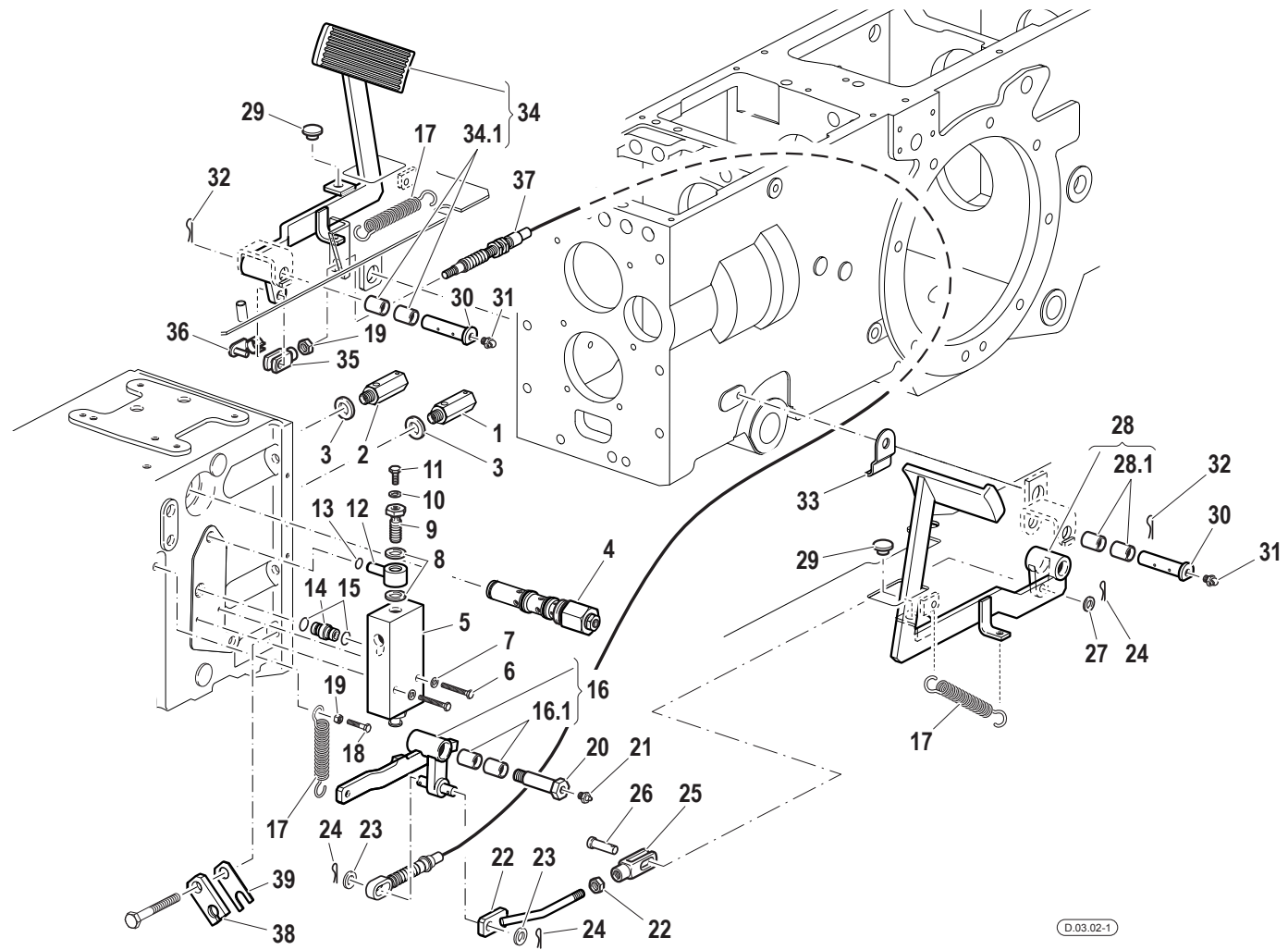



Pos.	Code	Q.ty	Description	Notes
1	59278554	1	VALVE	
2	59278555	1	VALVE	
3	F0843841000	2	COPPER WASHER 12,0x18/1,5	
4	58177754	1	VALVE	
5	58173030	1	SWITCH	
6	F0862345000	2	SCREW M6X40 UNI 5737	
7	F0843581010	2	SPRING WASHER 6	
8	F0843907000	2	COPPER WASHER 13,66x19/1,5	
9	58074558	1	PIPE FITTING	
10	F0843641000	1	COPPER WASHER 8x14/1,5	
11	F0862448100	1	SCREW M8X10 UNI 5740	
12	59074623	1	PRESSURE PIPE	
13	38110992	1	O-RING	
14	56170029	1	PIPE FITTING	
15	F0803057000	2	O-RING	
16	59073725	1	ROCKER	
16.1	58173195	2	BUSHING	
17	58070790	3	RESTORING SPRING	
18	F0862694000	1	SCREW M8X170 UNI 5737	
19	F0814569000	2	NUT	
20	56173684	1	PIN	
21	30000007	1	LUBRICATOR	
22	59073685	1	ROD	
23	31411105	2	WASHER 10,5x21	
24	F0810510000	2	SPLIT PIN A2,0X20 UNI 1336	
25	56074302	1	FORK	
26	F0835523000	1	PIN	
27	31411084	1	WASHER 8,4x17	
28	59074206	1	CLUTCH PEDAL	
28.1	58173195	2	BUSHING	
29	F0822537050	1	BUFFER	
30	56373194	2	HINGE PIN	
31	F0826039000	2	LUBRICATOR	
32	F0810527000	2	FRONT COVER	

SERIAL  
START  
**914705**

**CLUTCH CONTROLS**

CODE REV  
**D.03.02\_1\_39804**

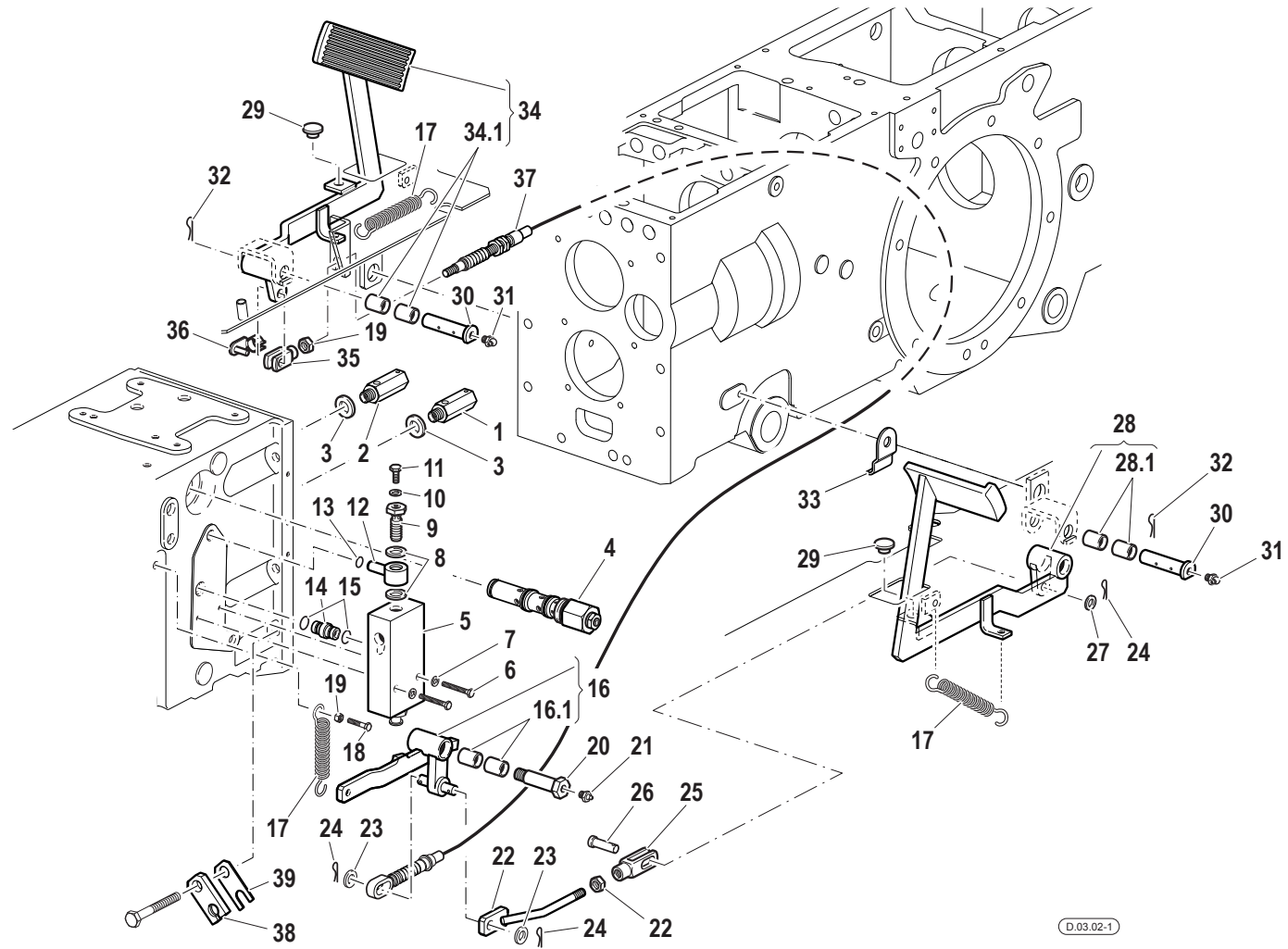

Pos.	Code	Q.ty	Description	Notes
33	56075230	1	BRACKET	
34	59074081	1	PEDAL	
34.1	58173195	4	BUSHING	
35	F0860058010	1	FORK	
36	F0860058020	1	PIN	
37	58174417	1	CABLE	
38	56174400	1	PLATE	
39	56174401	1	FIXING PLATE	

SERIAL  
START  
**914705**

**CLUTCH CONTROLS**

CODE REV  
**D.03.02\_1\_39804**

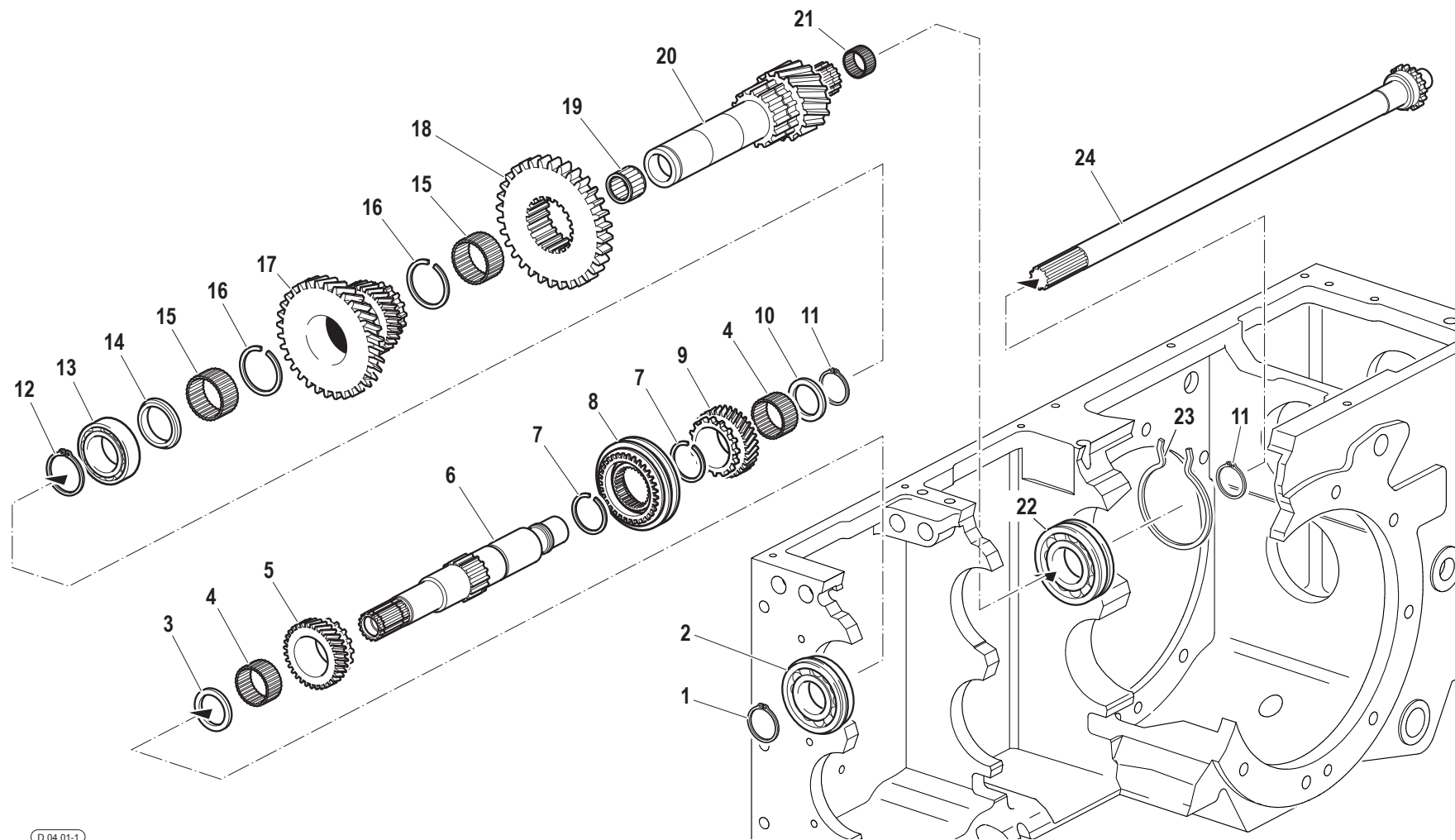

Pos.	Code	Q.ty	Description	Notes
1	F0801264050	1	SEEGER RING	
2	F0812868000	1	BEARING 6307-NR	
3	56470110	1	SHIM	
4	F0812878040	2	ROLLER CAGE K 40X45/27	
5	52473838	1	DRIVEN GEAR	
6	56473818	1	SHAFT	
7	F0801331150	2	SAFETY RING	
8	58170279	1	LOCK SYNCHRONIZER	
9	52473839	1	GEAR	
10	56470139	1	SHIM	
11	35121040	1	SEEGER RING	
12	F0801353000	1	SEEGER RING	
13	37112501	1	BEARING	
14	56470111	1	SHIM	
15	F0812951200	2	ROLLER CAGE K 50X55/20 H	
16	F0801380100	2	SAFETY RING	
17	52478618	1	DOUBLE GEAR	
18	52478619	1	GEAR	
19	F0812783000	1	ROLLER CAGE K 32X38/20	
20	52478620	1	OUTPUT SHAFT	
21	F0812660020	1	ROLLER CAGE K 22X26/17	
22	F0812918010	1	BEARING 6308-NR (40x90x23)	
23	58170130	1	CIRCLIP	
24	52473656	1	SHAFT	

SERIAL

**INPUT SHAFT / RANGES MAIN SHAFT / GEARS**

Version: RS-M, RS-R, AR-M, AR-R

CODE REV

**D.04.01\_1\_42845**

GEARS MAIN SHAFT / GEARS

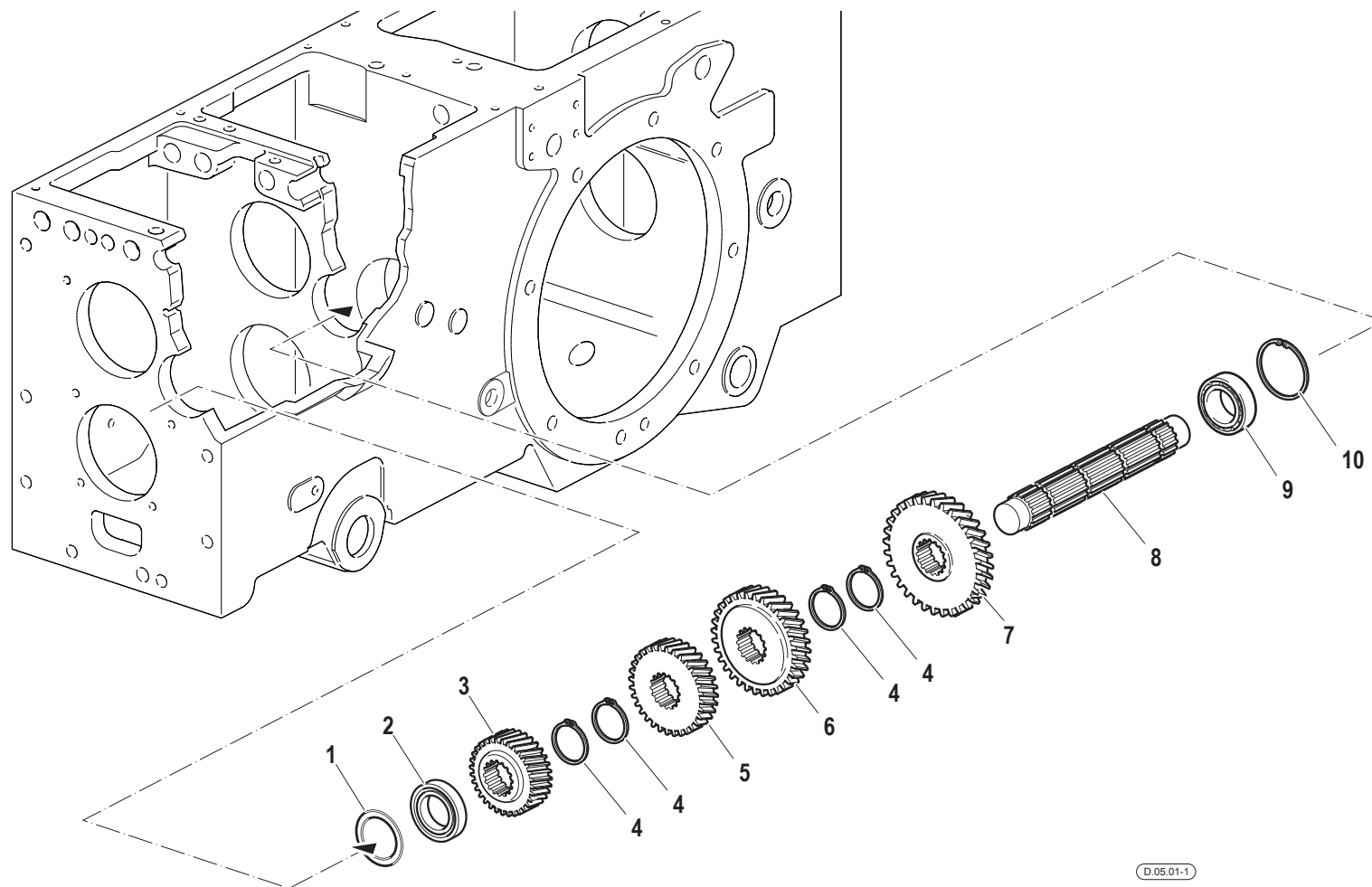

Pos.	Code	Q.ty	Description	Notes
1	F0850100000	1	SHIM 41x51/0,2	
1	F0850100010	1	SHIM 41x51/0,3	
1	F0850100020	1	SHIM 41x51/0,5	
2	F0812708030	1	BEARING NJ 205E	
3	52478612	1	GEAR	
4	F0801241010	4	SEEGER RING	
5	52473829	1	GEAR	
6	52473830	1	GEAR	
7	52473831	1	GEAR	
8	52473827	1	OUTPUT SHAFT	
9	37111255	1	BEARING	
10	35111052	1	SEEGER RING	

GEARS TRANSMISSION SHAFT / GEARS

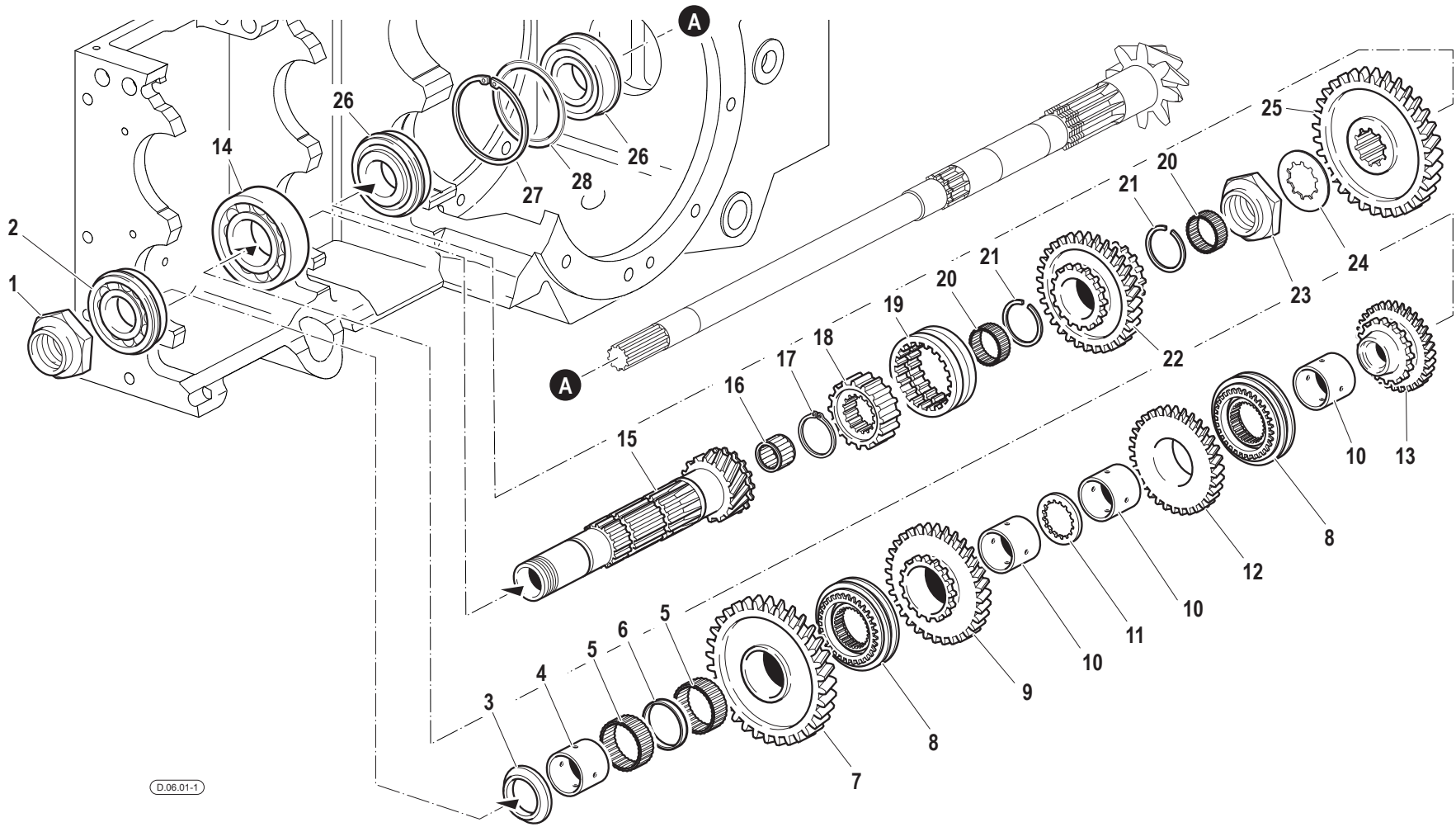



Pos.	Code	Q.ty	Description	Notes
1	56373840	1	RING NUT	
2	F0812899000	1	BEARING 6208-NR	
3	52478611	1	SHIM	
4	56578610	1	BUSHING	
5	F0812951070	2	ROLLER CAGE K 47X52/17 H	
6	56278614	1	SPACER	
7	52478609	1	DRIVEN GEAR	
8	58171139	2	LOCK SYNCHRONIZER	
9	52473835	1	DRIVEN GEAR	
10	56470138	3	BUSHING	
11	56470137	1	SHIM	
12	52473836	1	DRIVEN GEAR	
13	52473837	1	DRIVEN GEAR	
14	F0812957000	1	BEARING 6210 (50/90/20)	
15	52474251	1	COUNTERSHAFT	
16	F0812692015	1	ROLLER CAGE K 25X35/25	
17	35121035	1	SEEGER RING	
18	52470118	1	SLEEVE	
19	52470117	1	SLIDING SLEEVE	
20	F0812811000	2	ROLLER CAGE K 35X40/17	
21	F0801299100	2	SAFETY RING	
22	52478615	1	DOUBLE GEAR	
23	56378616	1	RING NUT	
24	56170760	1	RETAINING WASHER SP.1,0	
24	56174692	1	RETAINING WASHER SP.0,8	
24	56174693	1	RETAINING WASHER SP.0,9	
24	56174694	1	RETAINING WASHER SP.1,1	
24	56174695	1	RETAINING WASHER SP.1,2	
24	56175367	1	RETAINING WASHER SP.1,3	
25	52478617	1	GEAR	
26	37221320	2	BEARING	
27	35111080	1	SEEGER RING	
28	56370089	1	RING	
28	56370127	1	RING	

SERIAL

**GEARS TRANSMISSION SHAFT / GEARS**

Version: RS-M, RS-R, AR-M, AR-R

CODE REV

**D.06.01\_1\_42932**

GEARS TRANSMISSION SHAFT / GEARS

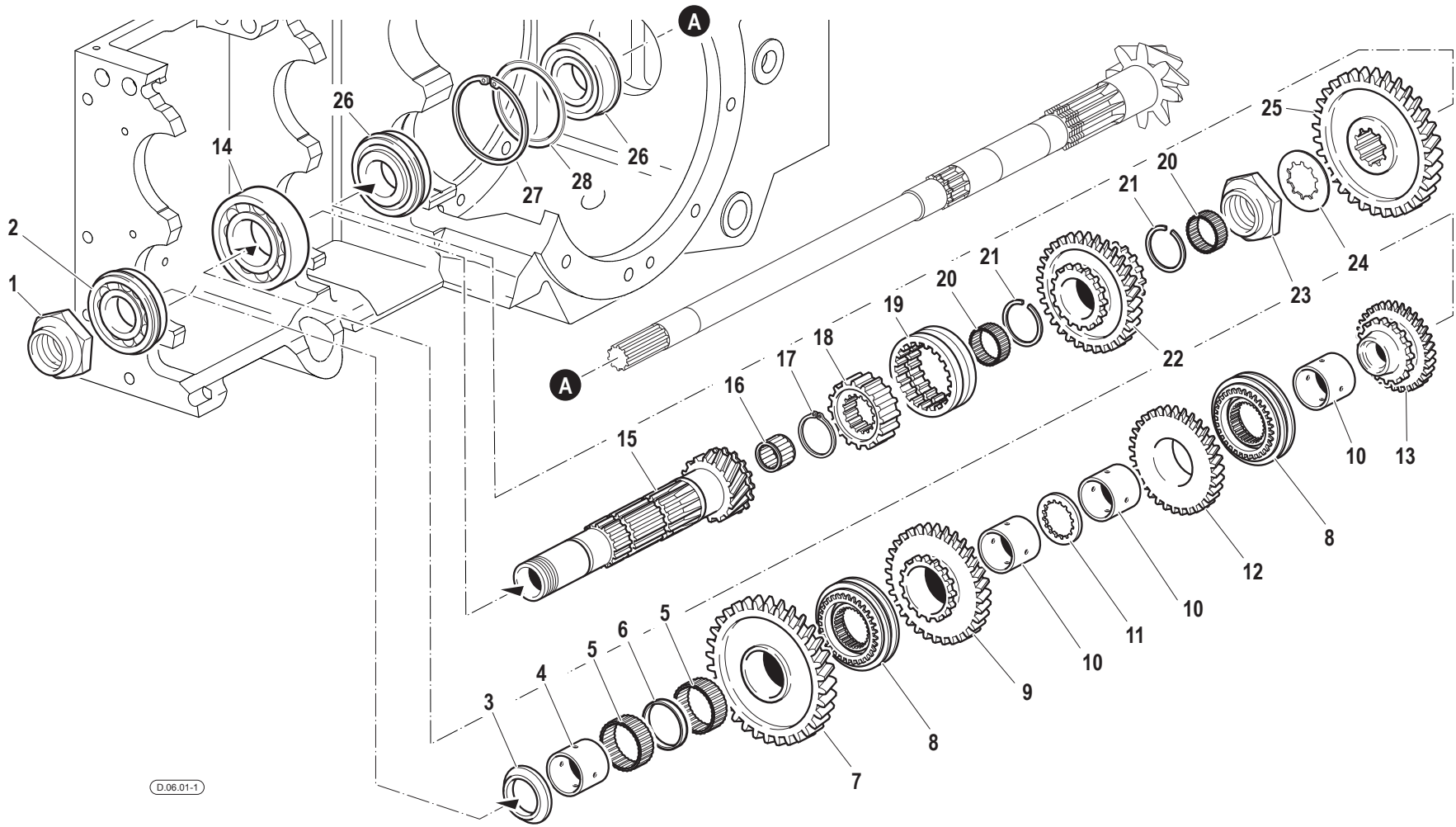

Pos.	Code	Q.ty	Description	Notes
28	56370128	1	RING	
28	56370830	1	RING	

# GEARBOX CONTROLS

SERIAL START 913987

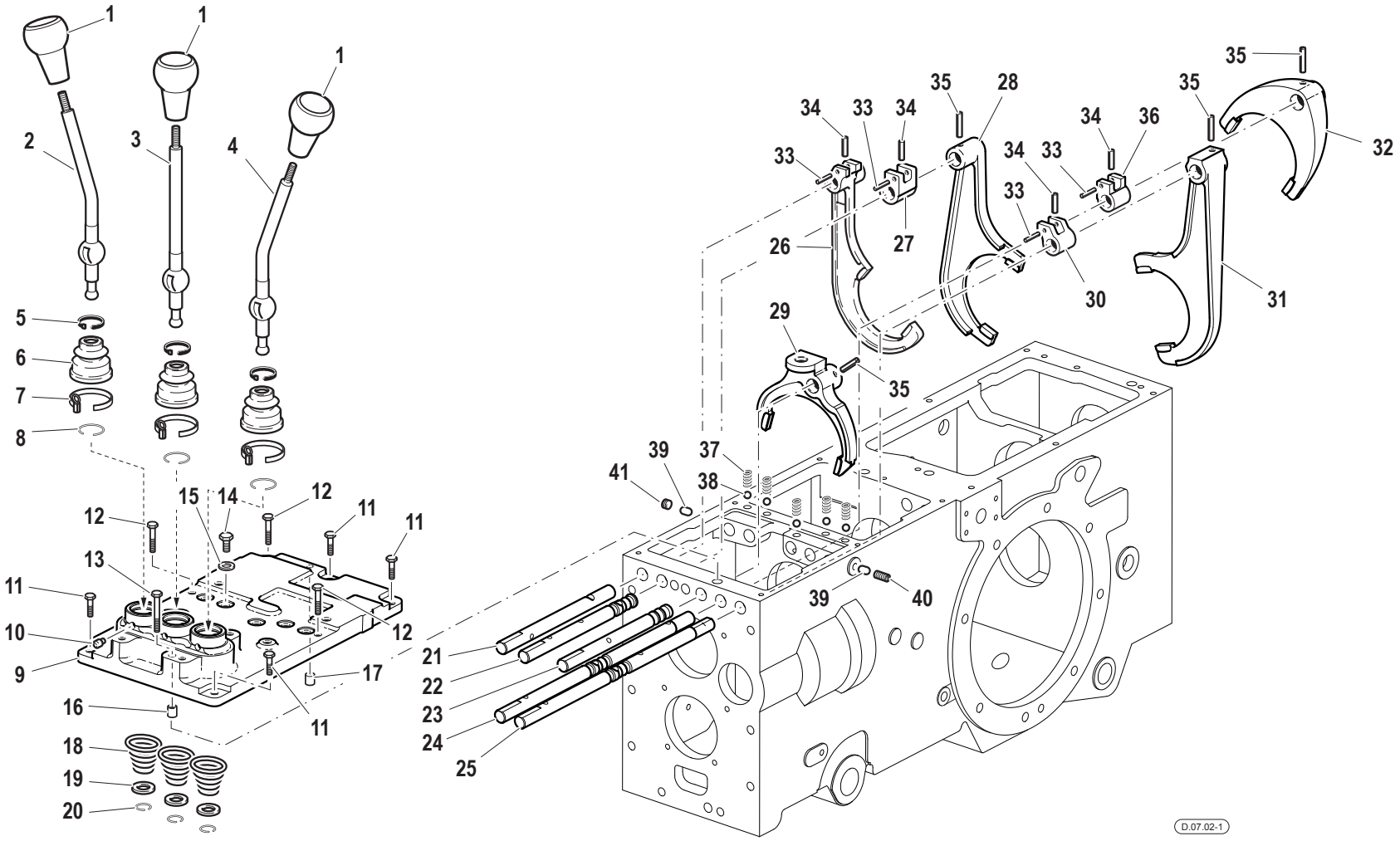

Pos.	Code	Q.ty	Description	Notes
1	58174192	3	HANDLE	
2	52374189	1	COMMAND LEVER	
3	52374386	1	COMMAND LEVER	
4	52378636	1	COMMAND LEVER	
5	F0817640003	3	CLAMP 4,8x180	
6	55170053	3	CAP	
7	58170054	3	COLLAR	
8	58070169	3	LOCKRING	
9	51179545	1	COVER	
10	56370018	6	HINGE PIN	
11	31112146	4	SCREW TE M8X22 UNI 5739 8G	
12	31112152	3	SCREW TE M8X30 UNI 5739 8G	
13	F0862944000	1	SCREW M8X60 UNI 5737	
14	56370186	5	PLUG	
15	F0843771000	5	COPPER WASHER 10,0x16/1	
16	56170017	1	PIN	
17	56570016	1	CYLINDRICAL PLUG	
18	58070164	3	SPRING	
19	56370172	3	SPACER	
20	58070168	3	LOCKRING	
21	56371065	1	PULL ROD	
22	56370177	1	PULL ROD	
23	56370165	1	ROD	
24	56378622	1	PULL ROD	
25	56378630	1	PULL ROD	
26	52274299	1	SELECTOR FORK	
27	52375896	1	CATCH	
28	52272112	1	SELECTOR FORK	
29	52273364	1	SELECTOR FORK	
30	52378629	1	CATCH	
31	51278623	1	SELECTOR FORK	
32	51270771	1	SELECTOR FORK	
33	F0851156000	4	PIN 4X30 DIN 1481 CL:C72	
34	F0851262000	4	PIN 6X26 DIN 7343 CL:C72	

SERIAL  
START  
**913987**

**GEARBOX CONTROLS**

CODE REV  
**D.07.02\_1\_39700**

# GEARBOX CONTROLS

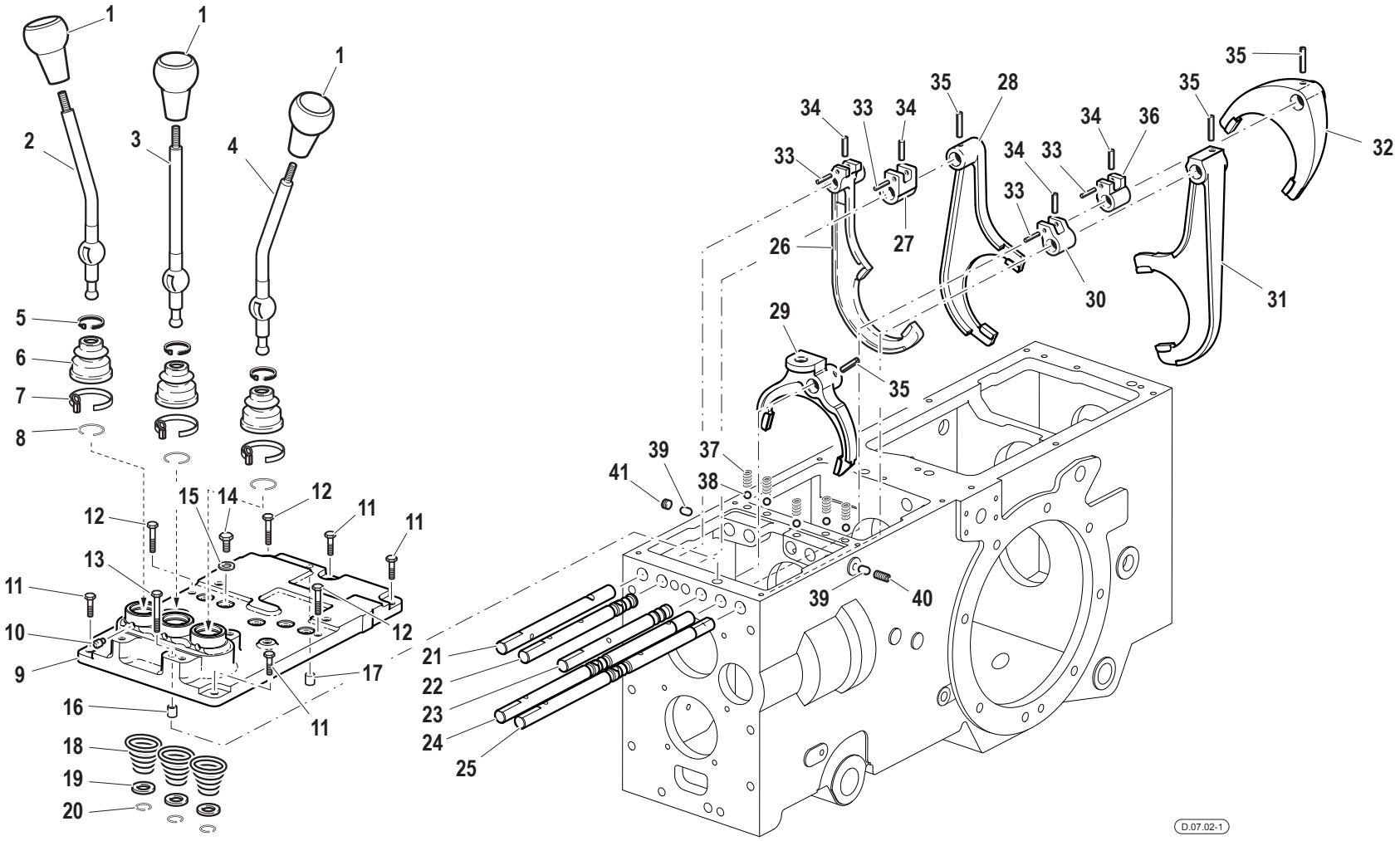

<b>Pos.</b>	<b>Code</b>	<b>Q.ty</b>	<b>Description</b>	<b>Notes</b>
35	F0851267050	3	PIN 6X30 DIN 7343 CL:C72	
36	52378628	1	CATCH	
37	58070741	5	SPRING	
38	F0847434000	5	BALL	
39	56570125	2	TOGGLE	
40	F0863183000	1	SCREW M10X16 UNI 5923	
41	F0852578060	1	CONICAL PLUG	

SERIAL  
START  
**913987**

**GEARBOX CONTROLS**

CODE REV  
**D.07.02\_1\_39700**

REAR TRANSMISSION

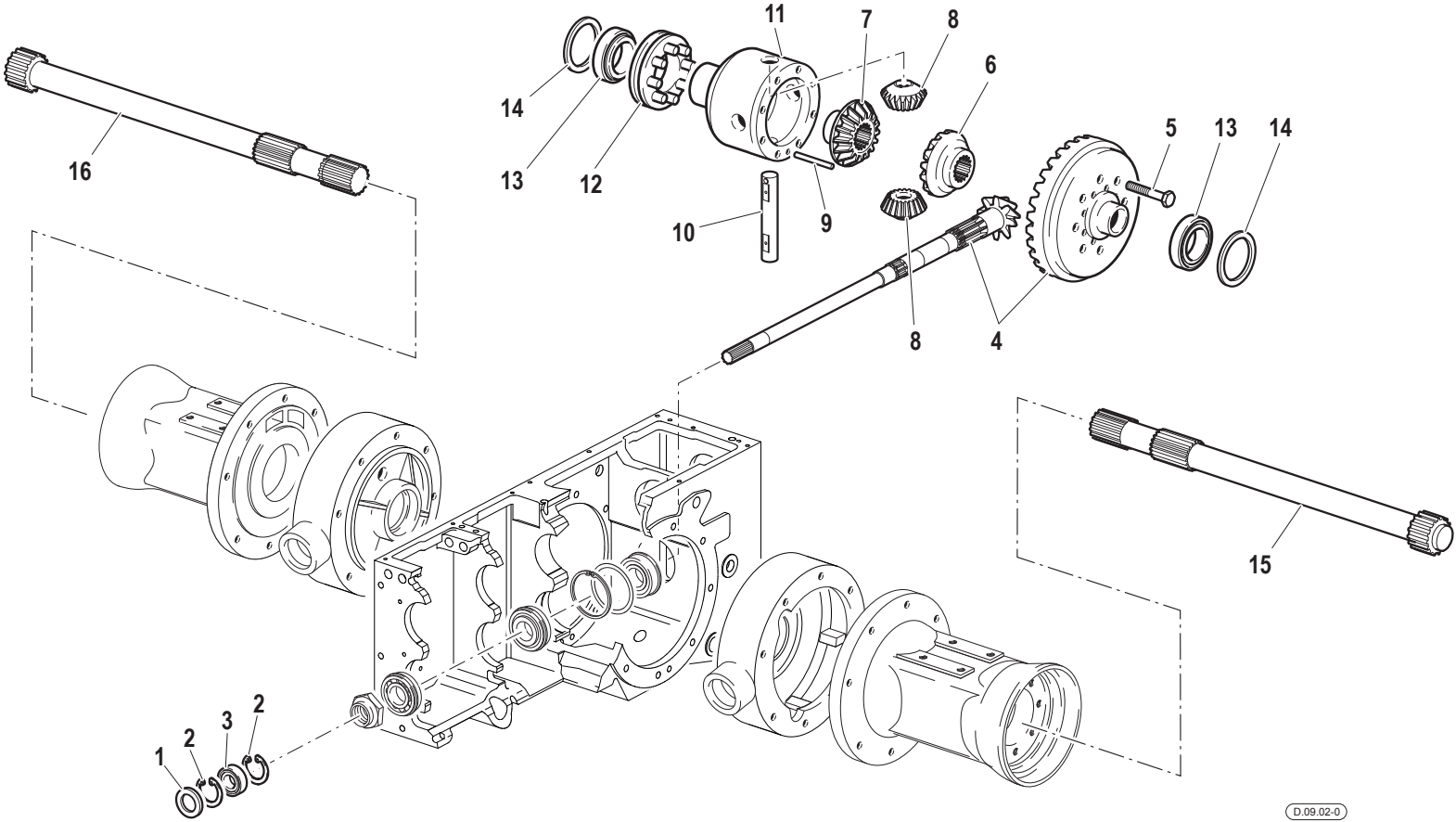



Pos.	Code	Q.ty	Description	Notes
1	F0802104000	1	OIL SEAL 25x62/10	
2	35111062	2	SEEGER RING	
3	37111254	1	BEARING	
4	59378814	1	BEVEL GEAR	
5	F0863311250	8	SCREW M10x1,5x32	
6	52470062	1	PINION	
7	52470061	1	PINION	
8	52470067	2	DIFFERENTIAL PINION	
9	56371037	1	PIN	
10	56471036	1	PIN	
11	51371035	1	HOUSING	
12	59070065	1	SLEEVE	
13	F0812956000	2	BEARING 32010 X/Q	
14	56370089	1	RING	
14	56370127	1	RING	
14	56370128	1	RING	
14	56370830	1	RING	
15	56470814	1	REAR AXLE SHAFT	
16	56470815	1	REAR AXLE SHAFT	

EPYCICLIC REDUCTION GEARS

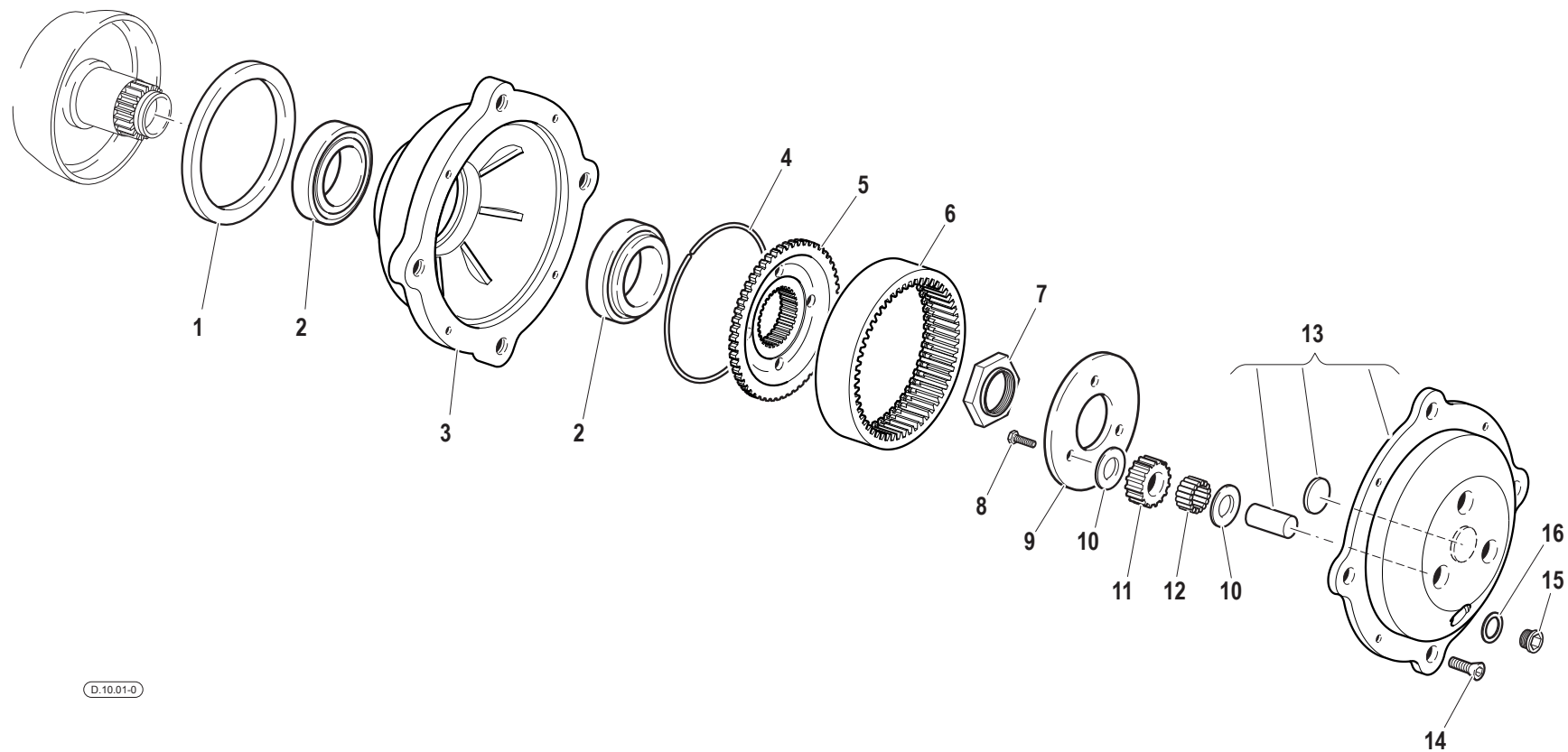

D.10.01-0

Pos.	Code	Q.ty	Description	Notes
1	F0802700150	1	SEAL 125x150x12	
2	F0812975250	2	CYL. ROLLER BEARING 32013X	
3	51172005	1	HUB	
4	58070071	1	RING	
5	52370075	1	FLANGE	
6	52370072	1	CROWN WHEEL	
7	56370079	1	RING NUT	
8	F0862478070	3	SCREW M8x16	
9	56170074	1	ADJUSTING RING	
10	56370076	6	SHIM	
11	52470087	3	PLANETARY GEAR	
12	58170070	3	ROLLER BEARING	
13	59070094	1	COVER	
14	F0862655000	4	SCREW M8X25-5933	
15	56370081	1	PLUG	
16	F0844273090	1	GASKET 22X28X1,5 CU 99,5	

# DIFFERENTIAL LOCK

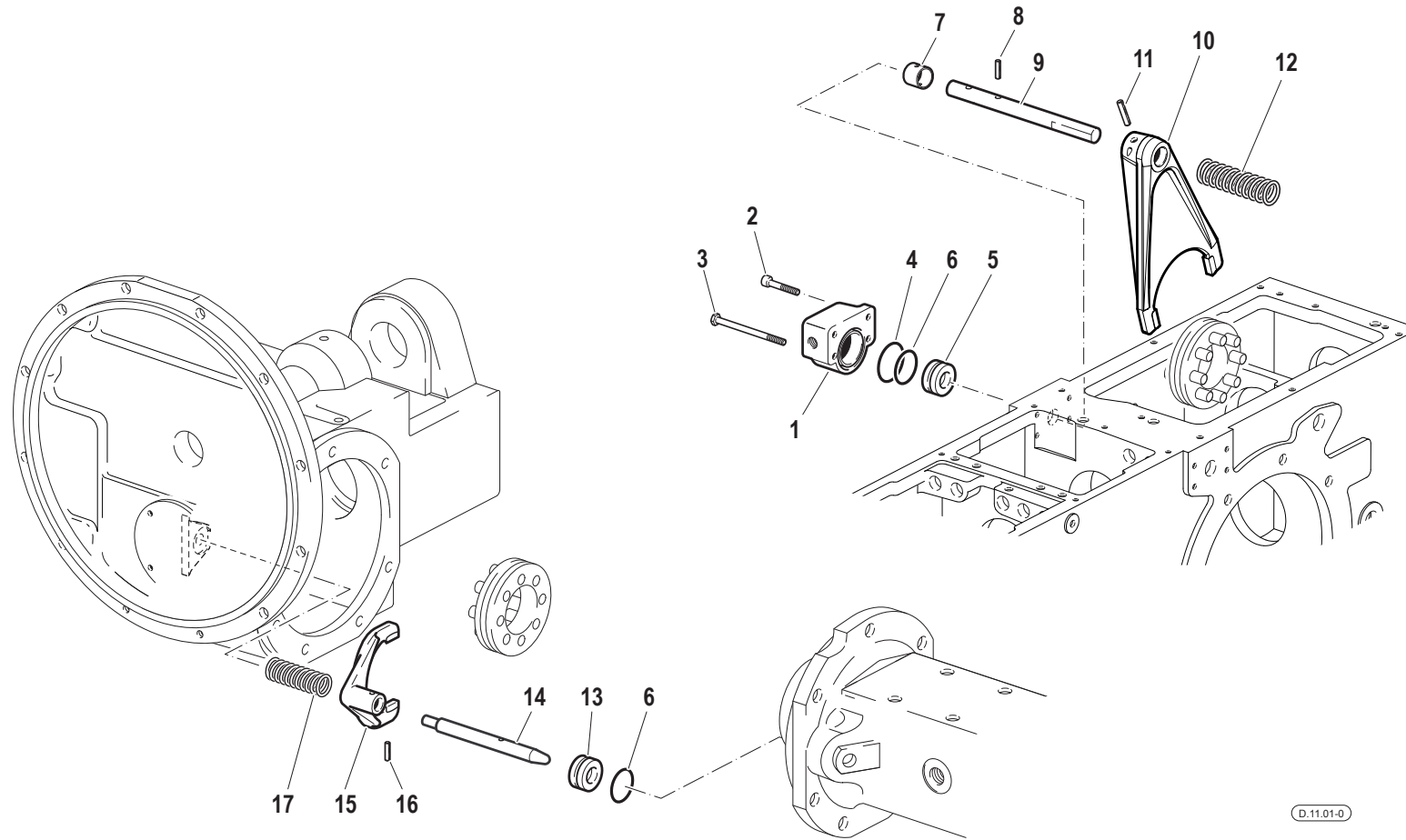

Pos.	Code	Q.ty	Description	Notes
1	52374641	1	SMALL BLOCK	
2	31152085	2	SCREW TCEI M8X25 UNI 5931	
3	31112161	2	SCREW TE M8X50 UNI 5737 8G	
4	F0803209000	1	O-RING	
5	56370187	1	PISTON	
6	58170195	2	GASKET	
7	56176127	1	BUSHING	
8	34213054	1	ROLL PIN	
9	56376256	1	LOCKING DEVICE	
10	51278573	1	FORK	
11	F0851267050	1	PIN 6X30 DIN 7343 CL:C72	
12	58070198	1	SPRING	
13	56370583	1	PISTON	
14	56370582	1	LOCKING DEVICE	
15	51270203	1	FORK	
16	F0851260000	1	PIN	
17	58070205	1	SPRING	

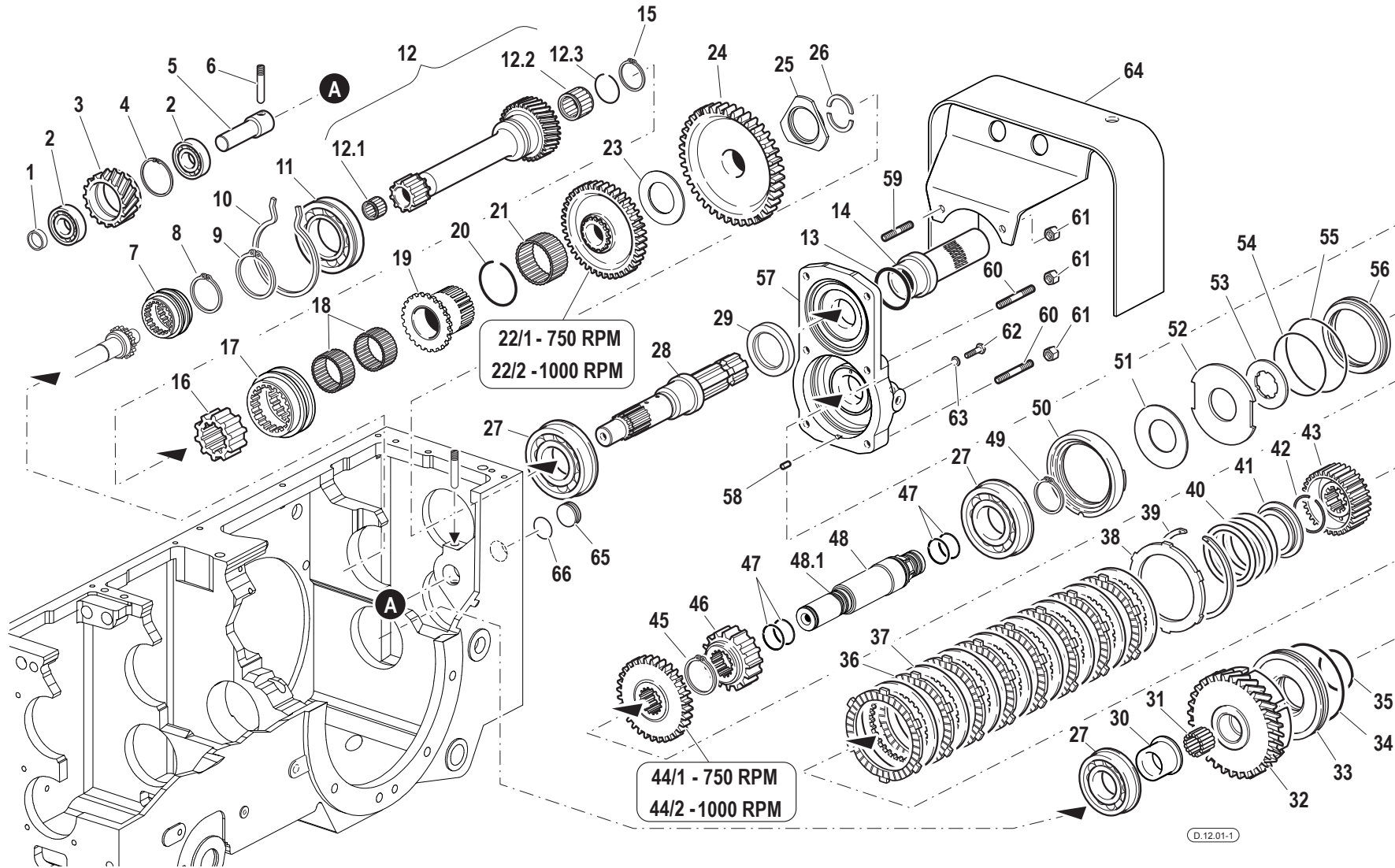

Pos.	Code	Q.ty	Description	Notes
1	56171572	1	SPACER	
2	F0812637000	2	BEARING 6204 (20x47x14)	
3	52476868	1	INTERMEDIATE WHEEL	
4	35111047	1	SEEGER RING	
5	56174108	1	GEAR PIN	
6	56370178	1	SCREW	
7	52470298	1	SLEEVE	
8	35121040	1	SEEGER RING	
9	F0801353000	1	SEEGER RING	
10	58170130	1	CIRCLIP	
11	F0812957010	1	BEARING 6210-N (50/90/20)	
12	59900376	1	PTO SHAFT	
12.1	F0812599086	1	BUSHING HK1816	
12.2	F0812689050	1	ROLLER CAGE K 25X33/20	
12.3	F0801248000	1	SAFETY RING	
13	P470433000000	1	PROTECTIVE RING	
14	P470330000000	1	GUARD	
15	F0801241010	1	SEEGER RING	
16	52476068	1	SLEEVE	
17	52476062	1	SHIFTING CLAW	
18	F0812784000	2	ROLLER CAGE K 32X37/27 H	
19	52478568	1	SHIFTING CLAW	
20	37931413	1	SAFETY RING	
21	F0812951300	1	ROLLER CAGE K 50X55/27 H	
22/1	52476065	1	DRIVEN GEAR	
22/2	52476066	1	DRIVEN GEAR	
23	56475568	1	SHIM	
24	52475991	1	DRIVEN GEAR	
25	56478567	1	SHIM	
26	56378566	2	HALF RING	
27	F0812918010	3	BEARING 6308-NR (40x90x23)	
28	52478565	1	PTO SHAFT	
29	F0802228005	1	SEAL 48x65/10	
30	56470987	1	BUSHING	

SERIAL  
START  
**911149**

**POWER TAKE-OFF**

CODE REV

**D.12.01\_1\_40279**

# POWER TAKE-OFF

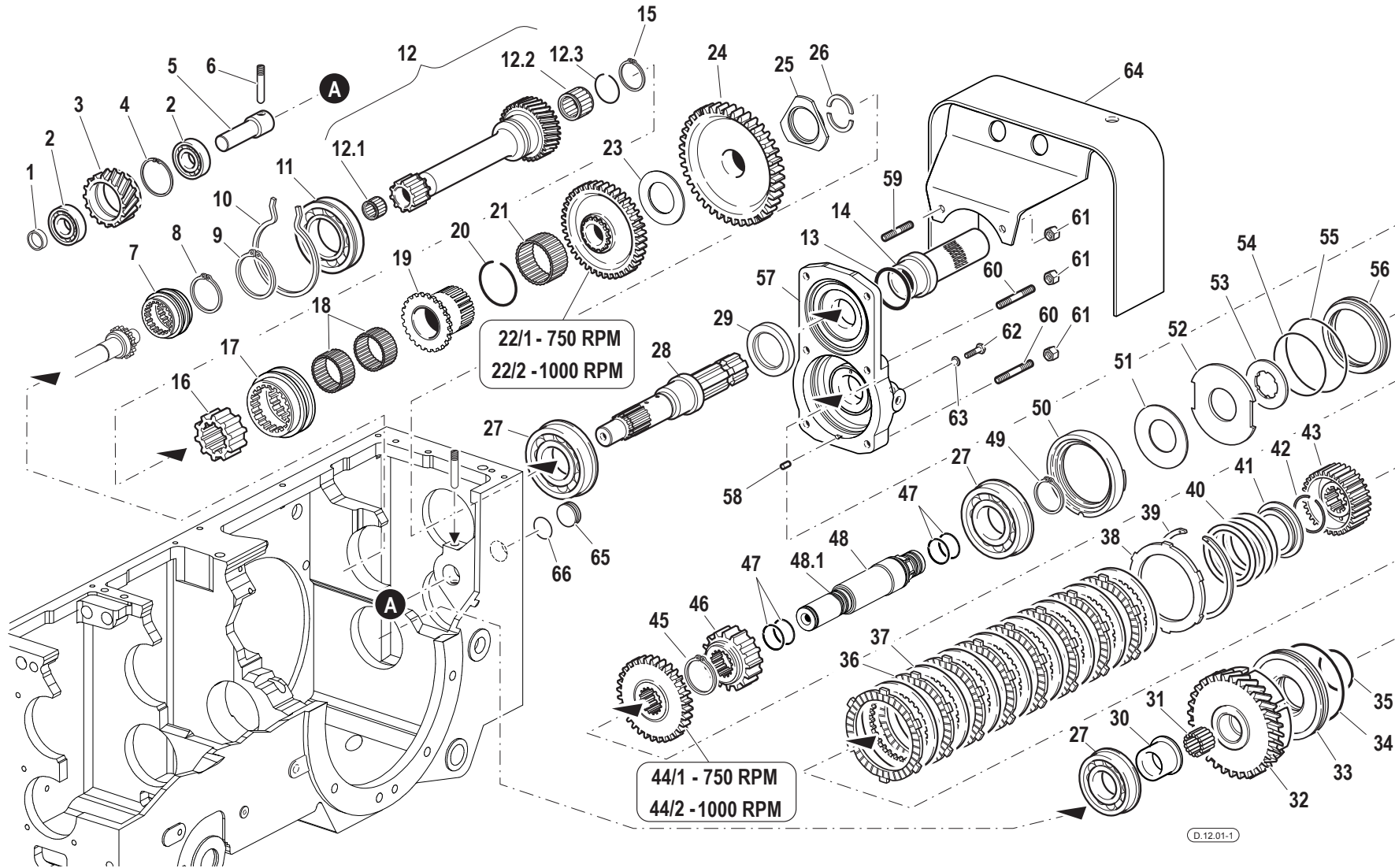



Pos.	Code	Q.ty	Description	Notes
31	F0812736010	1	ROLLER CAGE K 30X35/20 H	
32	52475562	1	CLUTCH HOUSING	
33	53273886	1	PISTON	
34	58172400	1	GASKET	
35	58172402	1	GASKET	
36	58172447	8	DISC	
37	58172448	8	DISC	
38	52372292	1	RING	
39	58072389	1	CIRCLIP	
40	58074092	1	RESTORING SPRING	
41	56372282	1	RING	
42	58072399	1	SAFETY RING	
43	52475565	1	DISC HUB	
44/1	52475994	1	GEAR	
44/2	52475996	1	GEAR	
45	F0801282050	1	SEEGER RING	
46	52475992	1	GEAR	
47	58072398	4	SEAL	
48	59276076	1	SHAFT	
48.1	F0852578060	2	CONICAL PLUG	
49	F0801297050	1	SEEGER RING	
50	56475516	1	SPACER	
51	58073889	1	CUP SPRING	
52	56475517	1	BRAKE DISC	
52	56475518	1	CLUTCH DISC	
52	56473890	1	BRAKE DISC	
52	56474713	1	BRAKE DISC	
52	56474714	1	BRAKE DISC	
53	56475844	1	CLUTCH DISC	
54	38116317	1	RING	
55	38118720	1	O-RING	
56	53273891	1	PISTON	
57	59377433	1	COVER	
58	F0851226000	1	PIN 6X12 UNI 1707 CL:C20	

SERIAL  
START  
**911149**

**POWER TAKE-OFF**

CODE REV

**D.12.01\_1\_40279**

# POWER TAKE-OFF

SERIAL START 911149

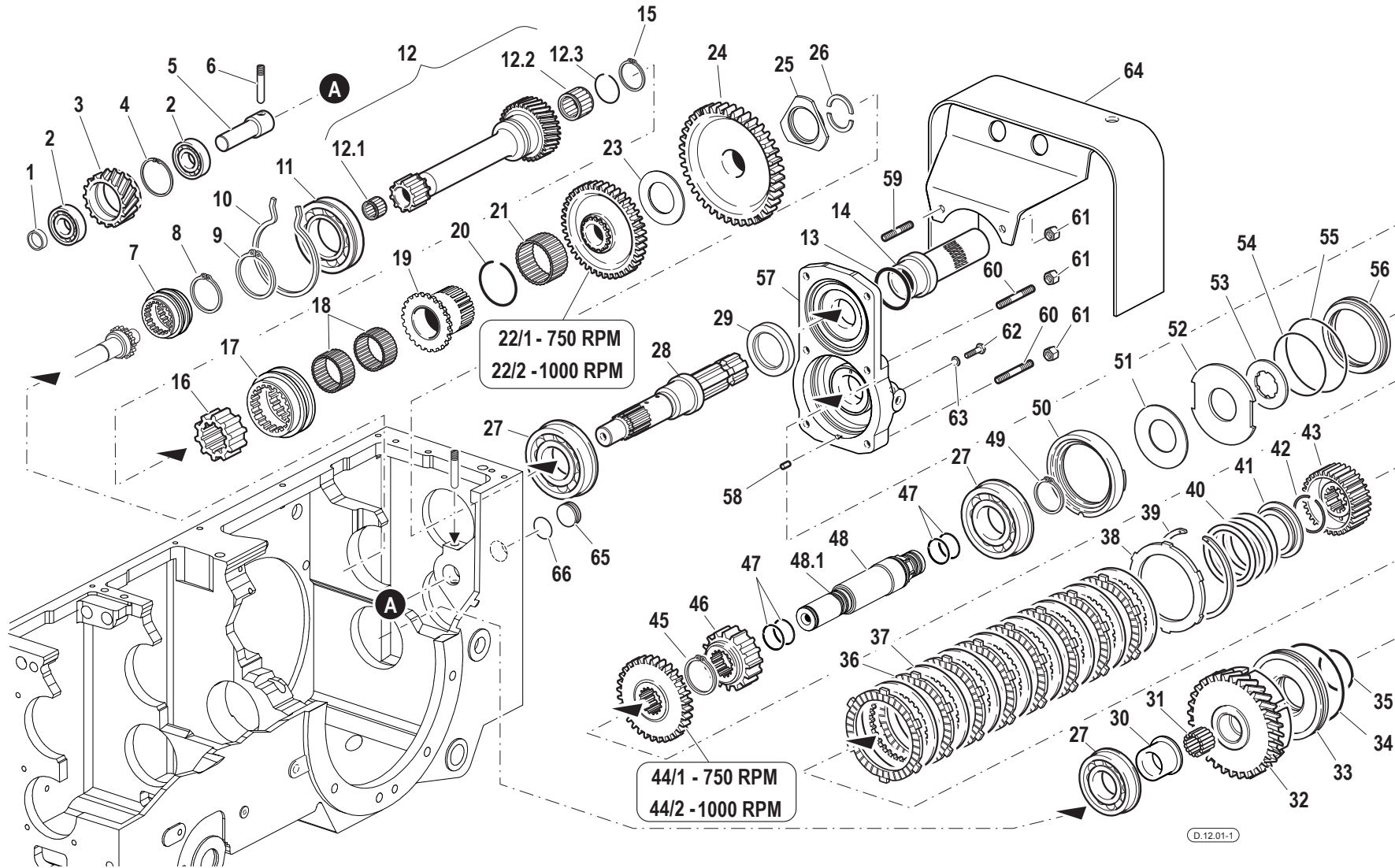

Pos.	Code	Q.ty	Description	Notes
59	F0838154010	2	STUD BOLT M8X25 UNI 5911 8.8	
60	31312089	4	STUD BOLT M8x52x14x18	
61	31211080	6	NUT M8	
62	F0862448100	1	SCREW M8X10 UNI 5740	
63	F0843641000	1	COPPER WASHER 8x14/1,5	
64	59074993	1	P.T.O. PROTECTION	
65	56074313	1	PLUG	
66	F0803199010	1	O-RING	

POWER TAKE-OFF CONTROLS

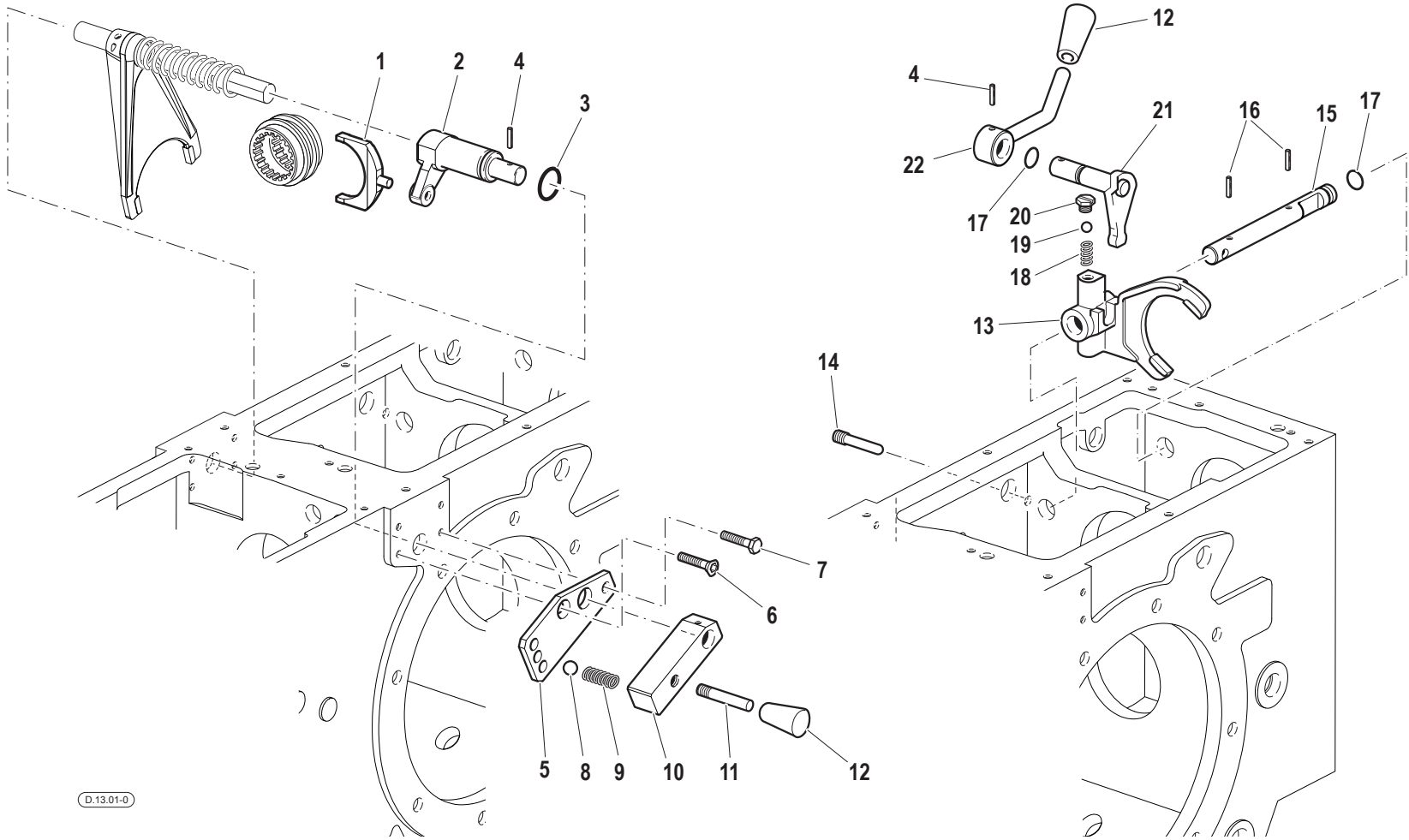

D.13.01-0

Pos.	Code	Q.ty	Description	Notes
1	56470299	1	SELECTOR FORK	
2	52370152	1	LEVER	
3	38112200	1	O-RING	
4	34211054	1	ROLL PIN	
5	56374430	1	PLATE	
6	31132566	1	SCREW TSVEI M8X20 UNI 5933	
7	31112150	1	SCREW TE M8X20 UNI 5739 8G	
8	F0847462000	1	BALL RB-11.112	
9	F0831047000	1	SPRING	
10	56174431	1	LEVER	
11	56170447	1	TIP	
12	F0828468050	2	GRIP	
13	51275570	1	SELECTOR FORK	
14	56370178	1	SCREW	
15	56375571	1	ROD	
16	F0851180000	2	PIN 5X26 DIN 1481 CL:C72	
17	38111078	2	O-RING	
18	58070741	2	SPRING	
19	F0847434000	2	BALL	
20	56076055	1	PLUG	
21	59075572	1	LEVER	
22	59078865	1	LEVER	

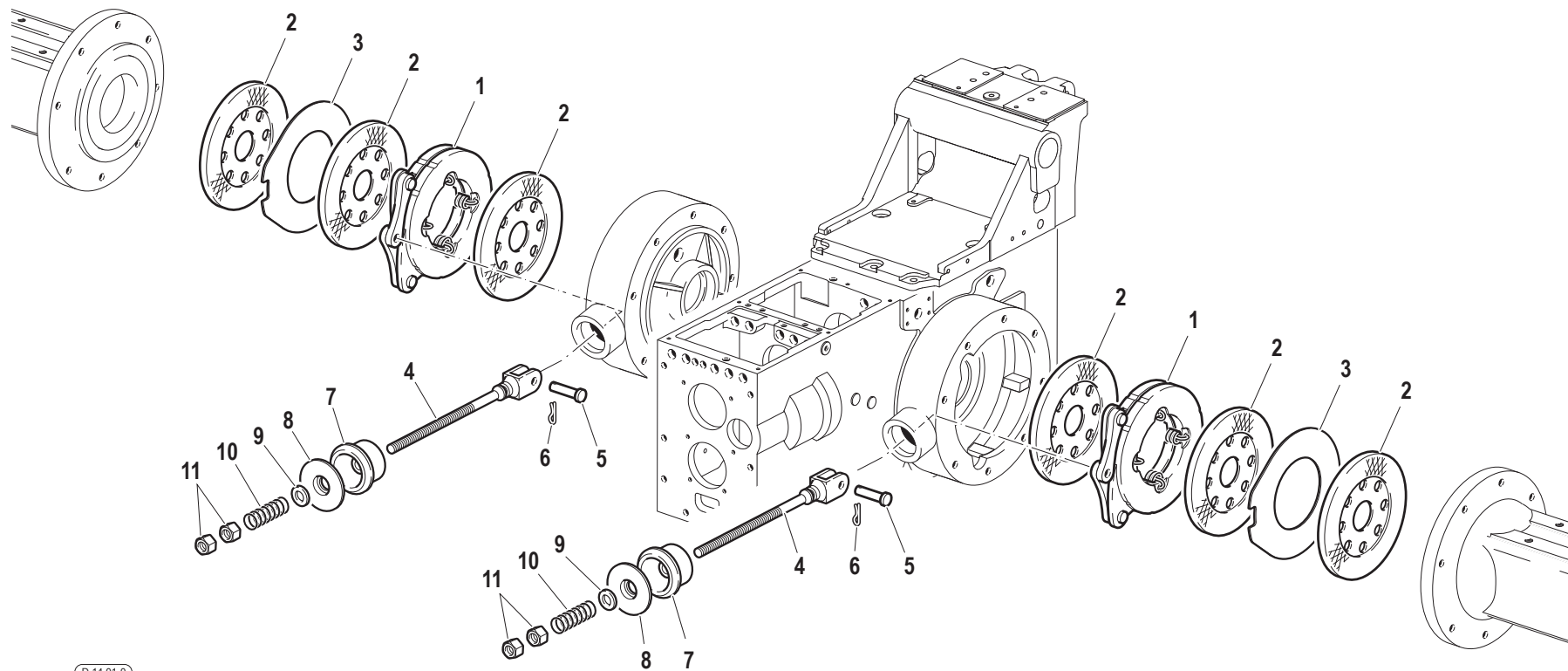

Pos.	Code	Q.ty	Description	Notes
1	58170045	2	BRAKE	
2	58170703	6	BRAKE DISC	
3	58171019	2	SHIM	
4	56370038	2	ROD	
5	56470231	2	PIN	
6	F0810510000	2	SPLIT PIN A2,0X20 UNI 1336	
7	55170047	2	BOOT	
8	56170043	2	COVER	
9	31411130	2	WASHER 13x24	
10	58070366	2	RETAINING SPRING	
11	31231120	4	NUT M12	

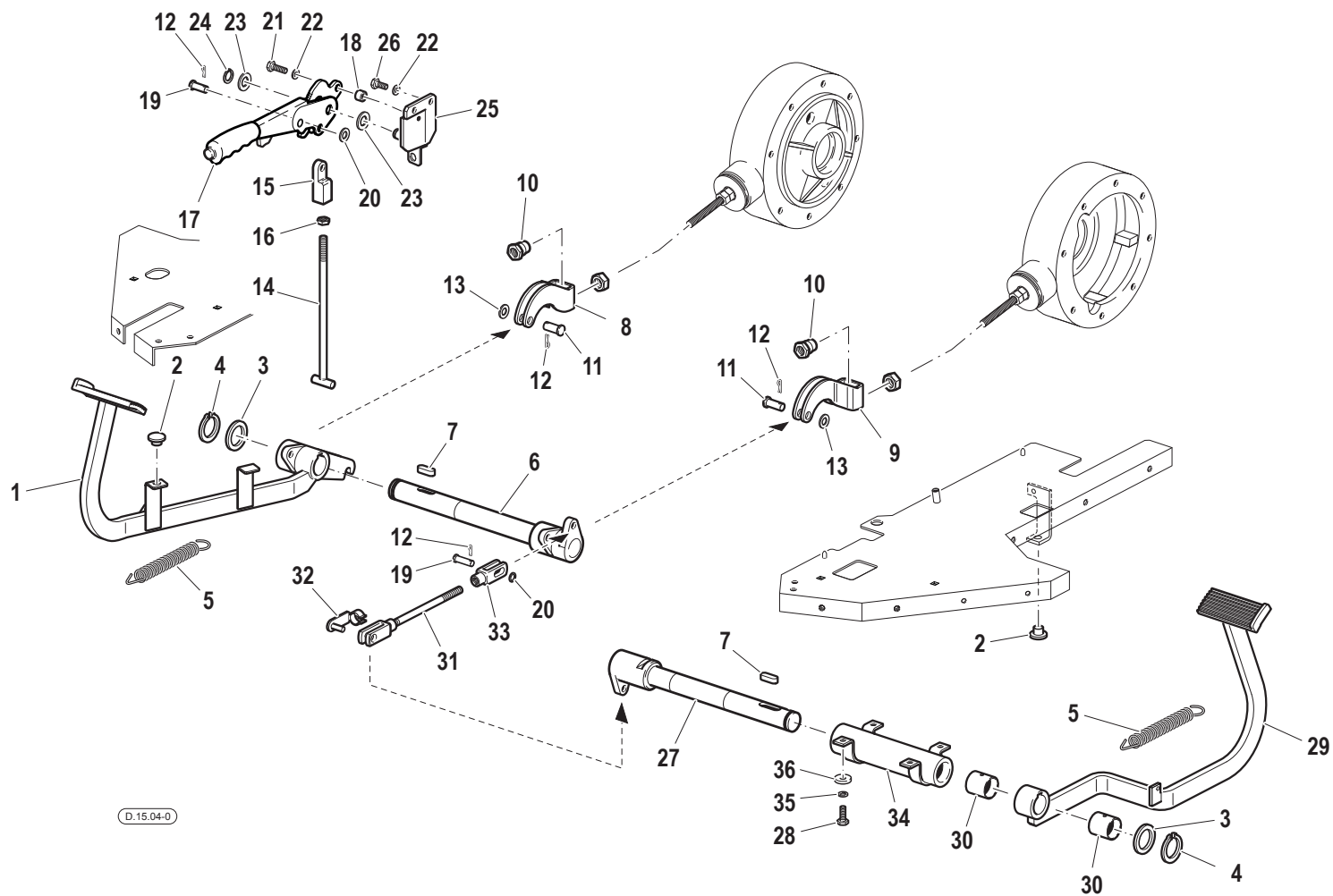

D.15.04-0



Pos.	Code	Q.ty	Description	Notes
1	59077228	1	BRAKE PEDAL	
2	F0822537050	2	BUFFER	
3	56170367	2	SHIM	
4	F0801241010	2	SEEGER RING	
5	58070790	2	RESTORING SPRING	
6	59070333	1	SHAFT	
7	34321066	2	KEY A10X8X30 UNI 6604	
8	56170795	1	RIGHT YOKE	
9	56170796	1	LEFT BRACKET	
10	52373177	2	NUT	
11	56470797	2	PIN	
12	F0810510000	4	SPLIT PIN A2,0X20 UNI 1336	
13	31411130	2	WASHER 13x24	
14	52375215	1	HANDBRAKE TIE-ROD	
15	56371721	1	SMALL BLOCK	
16	F0814627000	1	NUT M10	
17	58178960	1	HANDBRAKE LEVER	
18	56171936	1	SPACER	
19	56470365	2	PIN	
20	31411105	2	WASHER 10,5x21	
21	31112151	1	SCREW TE M8X25 UNI 5739 8G	
22	F0843643060	7	WASHER 8	
23	31411150	2	WASHER 15x28	
24	F0801095000	1	SEEGER RING	
25	59074459	1	RETAINER	
26	31112147	2	SCREW TE M8X18 UNI 5739 8G	
27	59077234	1	SHAFT	
28	31112146	4	SCREW TE M8X22 UNI 5739 8G	
29	59077233	1	BRAKE PEDAL	
30	58170026	2	BUSHING	
31	59073242	1	ROD	
32	F0860091020	1	PIN	
33	50970418	1	FORK	
34	59070051	1	PIPE	

SERIAL

**BRAKES CONTROLS**

CODE REV

**D.15.04\_0\_40488**

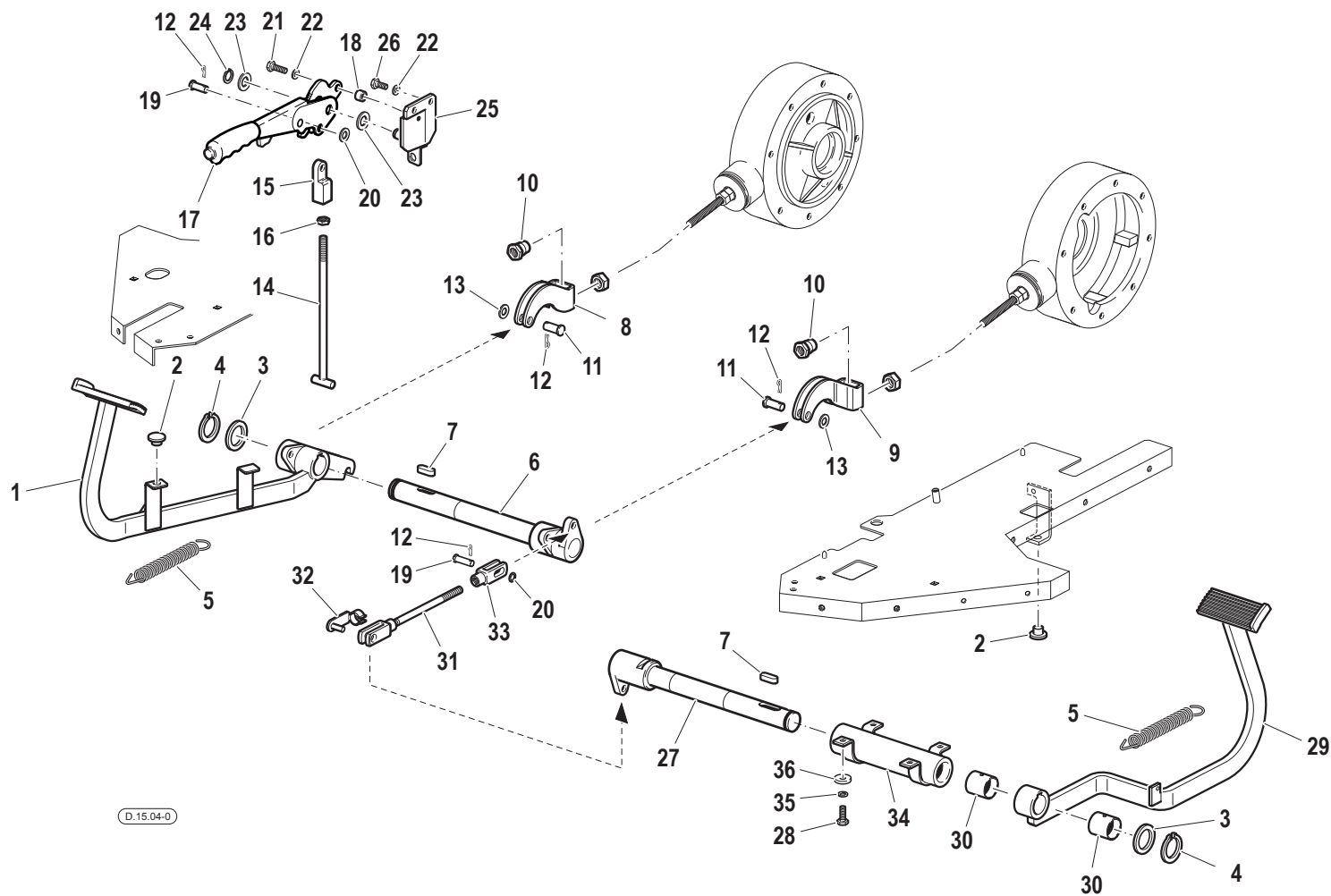

D.15.04-0

Pos.	Code	Q.ty	Description	Notes
35	F0843711000	4	WASHER D.24x8,5/4	
36	56077235	1	SPACER	

FRONT ELECTRICAL SYSTEM

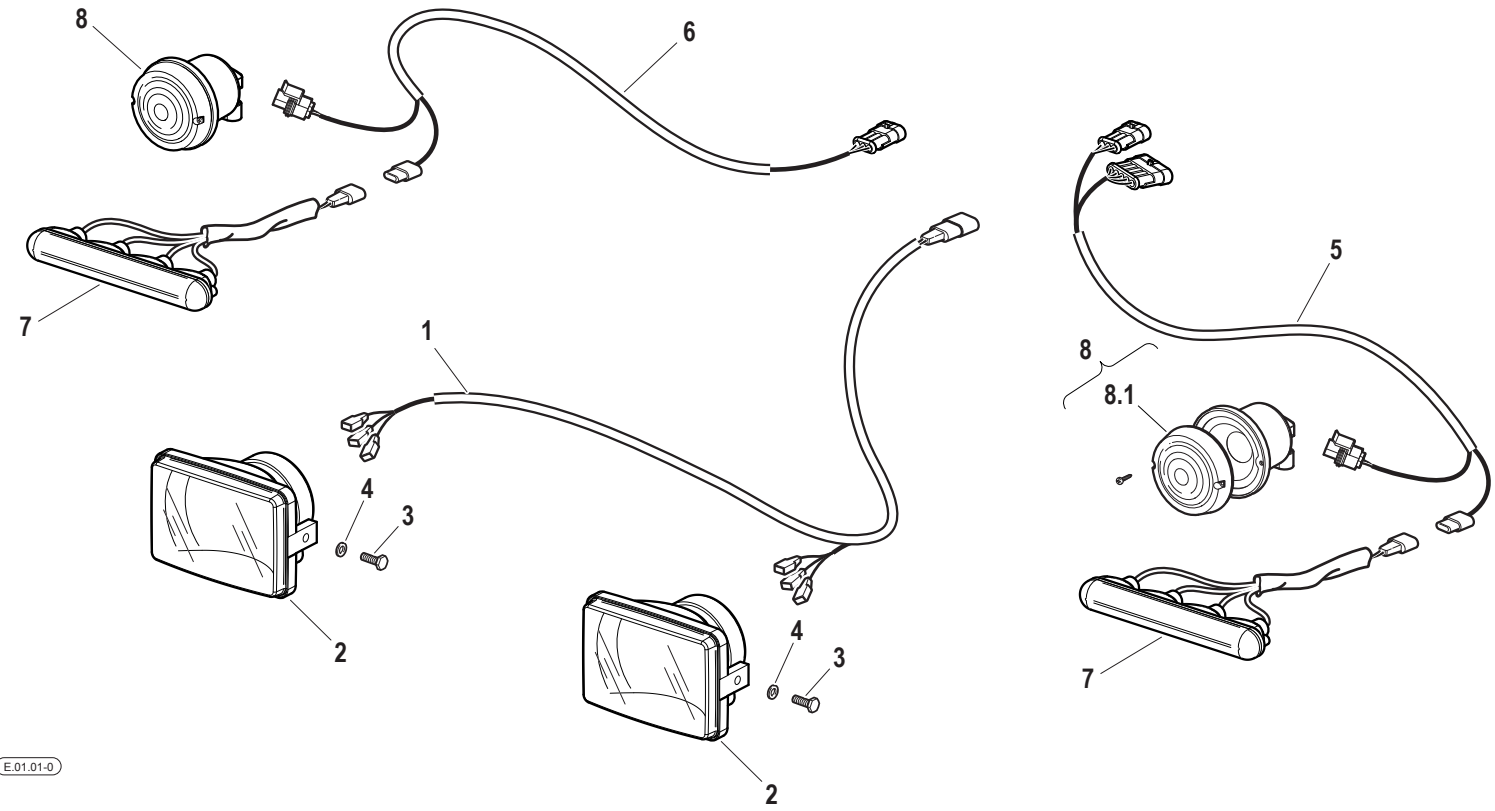

E.01.01-0

Pos.	Code	Q.ty	Description	Notes
1	58074904	1	CABLE	
2	58179010	2	OPTICAL GROUP	
3	31112082	4	SCREW TE M6X12 UNI 5739 8G	
4	31411064	4	WASHER 6,4x12,5	
5	58079395	1	CABLE	
6	58079394	1	CABLE	
7	58176406	2	INDICATOR	
8	58179413	2	POSITION LIGHT	
8.1	59901086	2	VETRO BIANCO FARO ANT.03438001	

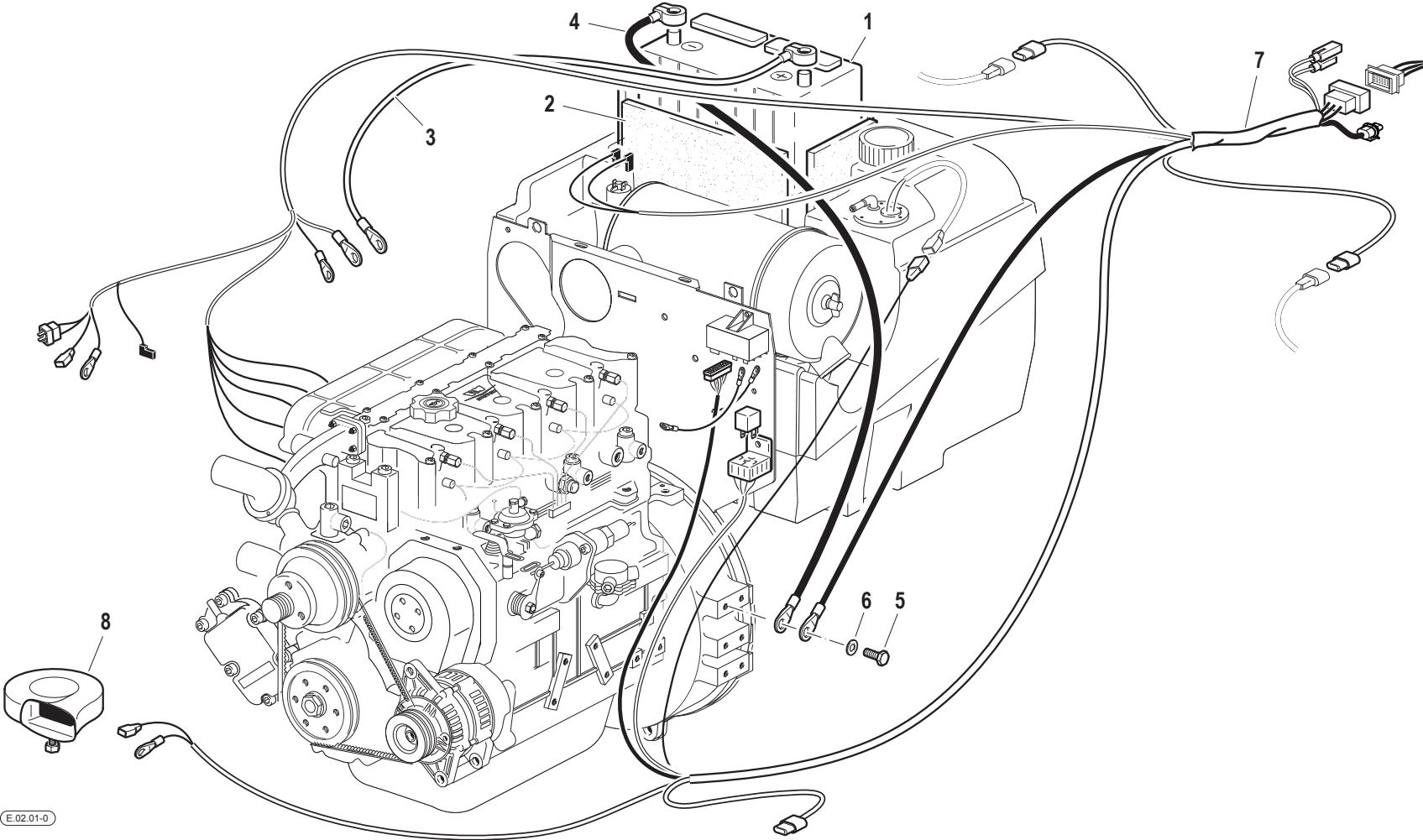

<b>Pos.</b>	<b>Code</b>	<b>Q.ty</b>	<b>Description</b>	<b>Notes</b>
1	F0825480100	1	BATTERY	
2	F0190018909	1	LINING	
3	58071313	1	CABLE	
4	58072081	1	CABLE	
5	31112210	1	SCREW TE M10X20 UNI 5739	
6	F0843755000	1	WASHER 10	
7	58079755	1	CABLE	
8	F0825417000	1	HORN	

STRUMENTAZIONE DIGITALE  
 DIGITAL INSTRUMENT  
 INSTRUMENTATION DIGITALE  
 DIGITALES GERÄT TAFEL  
 INSTRUMENTACIÓN DIGITAL

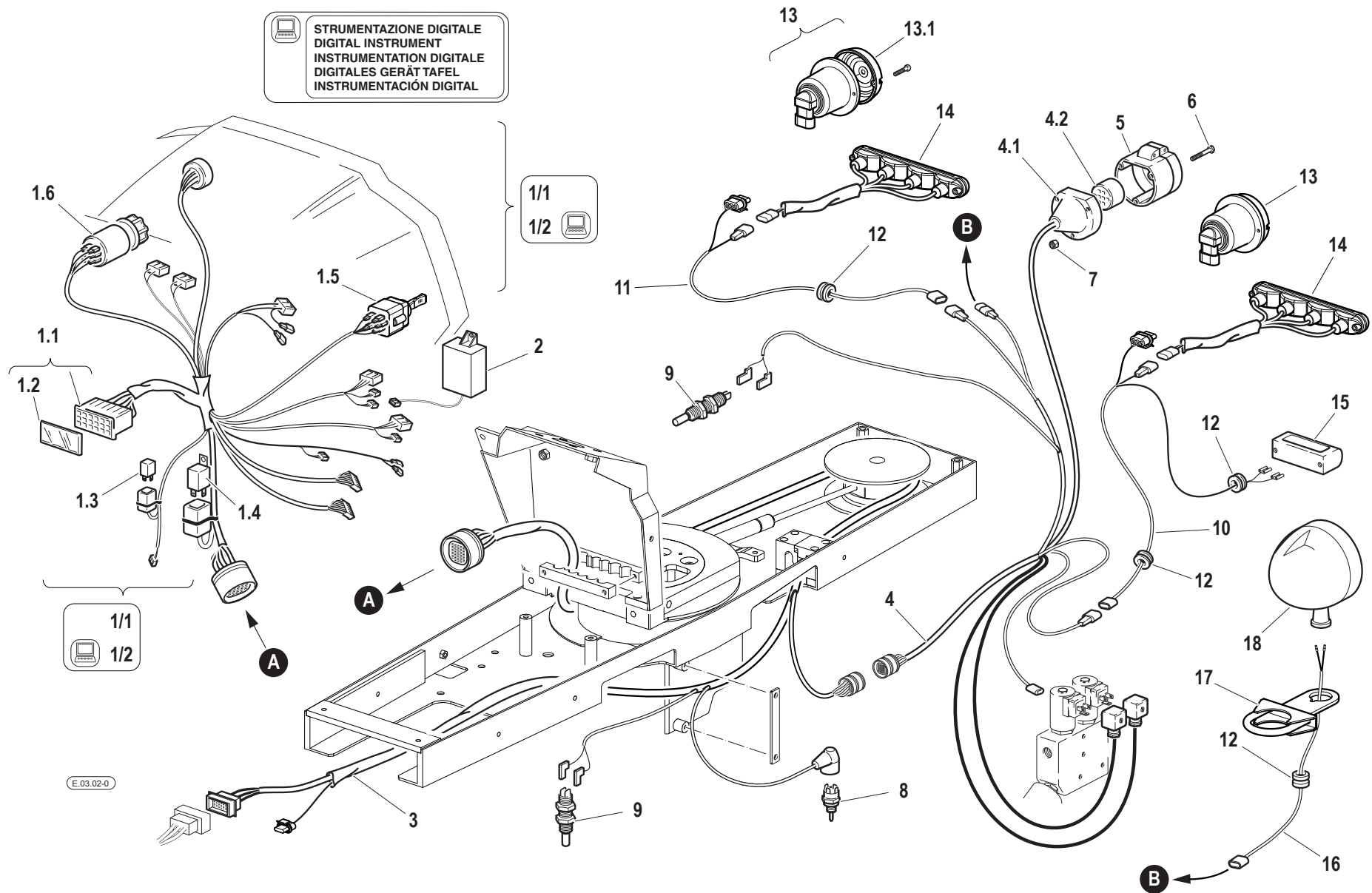

E.03.02-0



Pos.	Code	Q.ty	Description	Notes
1/1	58077601	1	CABLE	
1.1	58170453	1	FUSE BOX	
1.2	58172267	1	COVER	
1/2	58077602	1	CABLE	
1.3	59900242	1	RELAY	
1.4	F0825139000	1	FLASHER	
1.5	F0825436000	1	SWITCH	
1.6	F0825436003	1	SWITCH	
2	58175700	1	SWITCHING CONTROL UNIT	
3	58079392	1	CABLE	
4	58079393	1	CABLE	
4.1	58170572	1	CAP	
4.2	58170571	1	ATTACHMENT PLUG	
5	F0825438000	1	SOCKET	
6	F0861941000	3	SCREW	
7	31211050	3	NUT M5	
8	30000638	1	SWITCH	
9	F0825488000	2	SWITCH	
10	58077061	1	CABLE	
11	58077062	1	CABLE	
12	58171901	4	CABLE GLAND 15,5-24-32-2	
13	58176396	2	LAMP	
13.1	59901087	2	REAR LIGHT GLASS	
14	58176406	2	INDICATOR	
15	30000506	1	LAMP	
16	58077305	1	CABLE	
17	59077242	1	SUPPORT	
18	F0825493000	1	HEADLIGHT	

# HYDR. SYSTEM DOUBLE OIL SUCTION

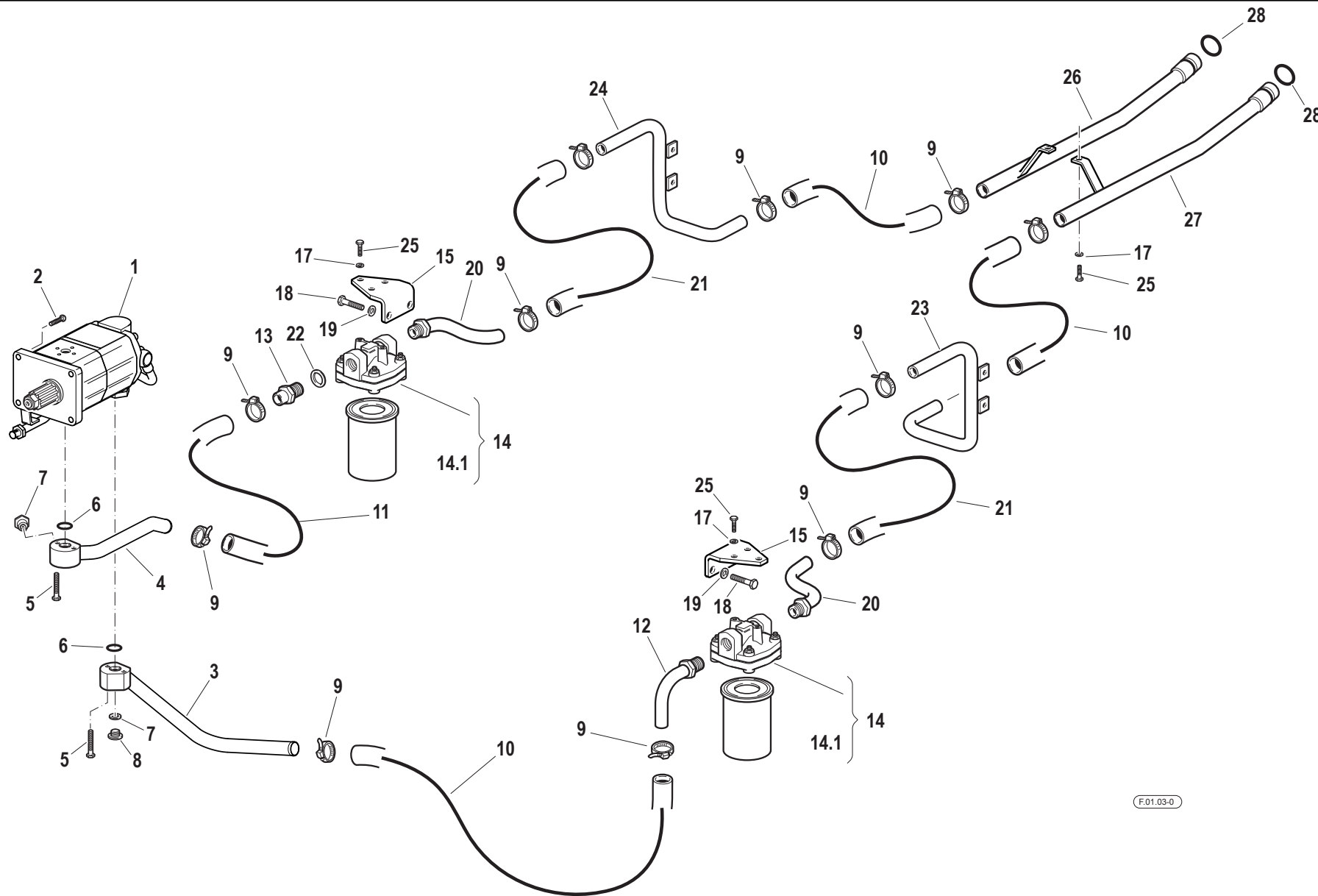

Pos.	Code	Q.ty	Description	Notes
1	58179463	1	LIFT PUMP	
2	31152083	4	SCREW TCEI M8X30 UNI 5931	
3	59079479	1	SUCTION PIPE	
4	59076211	1	SUCTION PIPE	
5	F0862796000	4	SCREW M8X40 UNI 5931	
6	38112200	2	O-RING	
7	F0852538050	1	PLUG	
8	F0843907000	1	COPPER WASHER 13,66x19/1,5	
9	F0817503000	12	CLAMP 037,6-906R	
10	58173505	1	FLEXIBLE HOSE	
11	58176337	1	SUCTION PIPE	
12	59076213	1	PIPE	
13	56170350	1	PIPE FITTING	
14	58175014	2	FILTER	
14.1	F0825718020	2	FILTER INSERT	
15	56174725	2	OIL FILTER BRACKET	
16	31111151	4	SCREW TE M8X16 UNI 5739 8G	
17	F0843643060	14	WASHER 8	
18	31112210	4	SCREW TE M10X20 UNI 5739	
19	F0843755000	4	WASHER 10	
20	59076212	2	PIPE	
21	58176336	1	SUCTION PIPE	
22	F0824185000	1	COPPER WASHER 26X34X1,5	
23	59076226	1	PIPE	
24	59078595	1	PIPE	
25	31112150	4	SCREW TE M8X20 UNI 5739 8G	
26	59076225	1	SUCTION PIPE	
27	59076224	1	SUCTION PIPE	
28	38113142	2	O-RING	

HYDR. SYSTEM : HEAT EXCHANGER

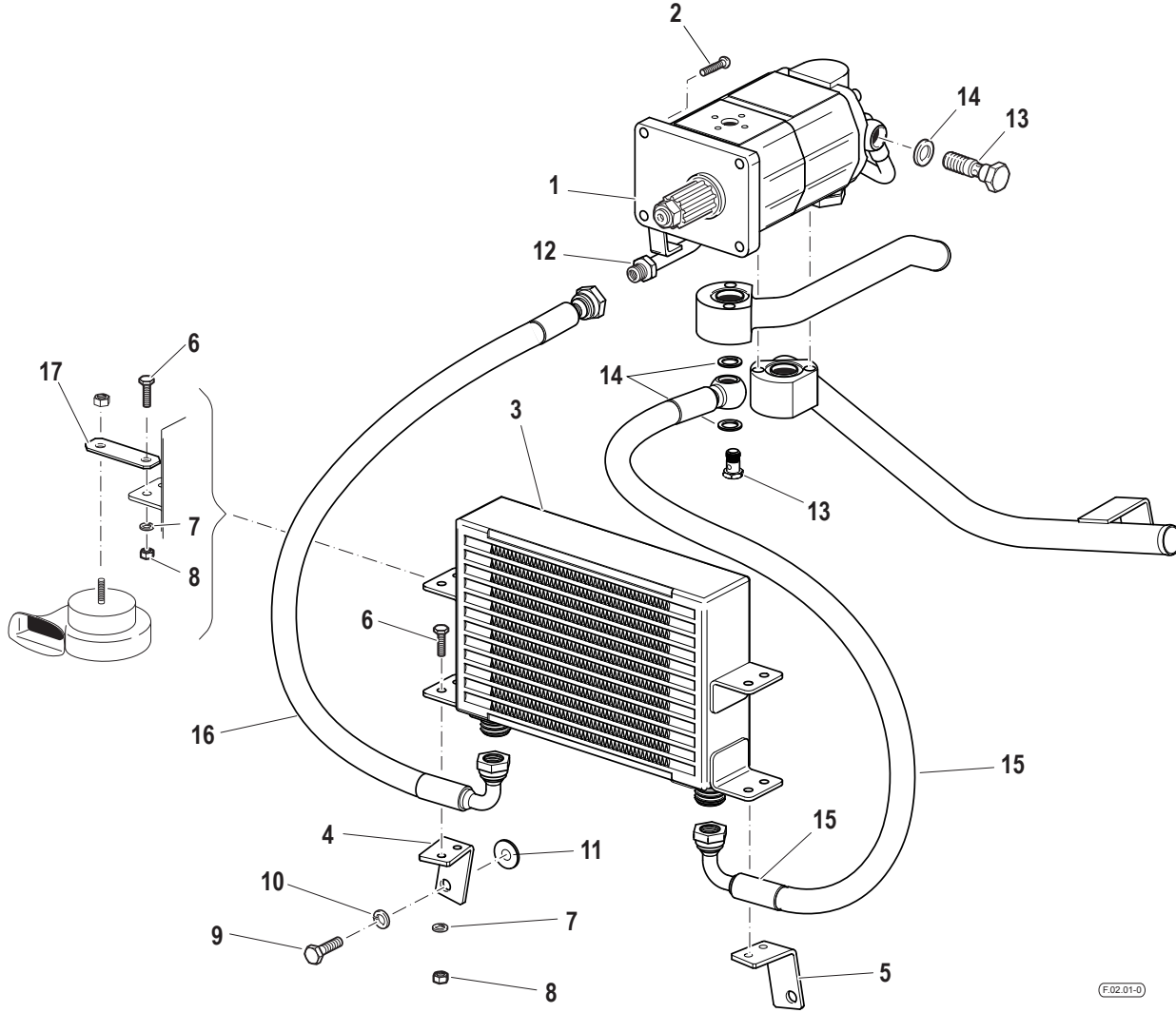

Pos.	Code	Q.ty	Description	Notes
1	58179463	1	LIFT PUMP	
2	31152083	4	SCREW TCEI M8X30 UNI 5931	
3	58177182	1	OIL EXCHANGER	
4	56174987	1	RIGHT YOKE	
5	56174988	1	LEFT BRACKET	
6	31112090	4	SCREW TE M6X16 UNI 5739 8G	
7	F0843570000	4	WASHER 6	
8	31211060	4	HEXAGONAL NUT M8	
9	31112210	2	SCREW TE M10X20 UNI 5739	
10	F0843755000	2	WASHER 10	
11	F0843815000	2	WASHER D.24x10,5/4	
12	59079478	1	PRESSURE PIPE	
13	56172547	1	THREADED TERMINAL END	
14	F0824113000	2	COPPER WASHER 18X24/1,5	
15	58076333	1	FLEXIBLE HOSE	
16	58076334	1	FLEXIBLE HOSE	
17	56175294	1	BRACKET	

# STEERING HYDR. SYSTEM

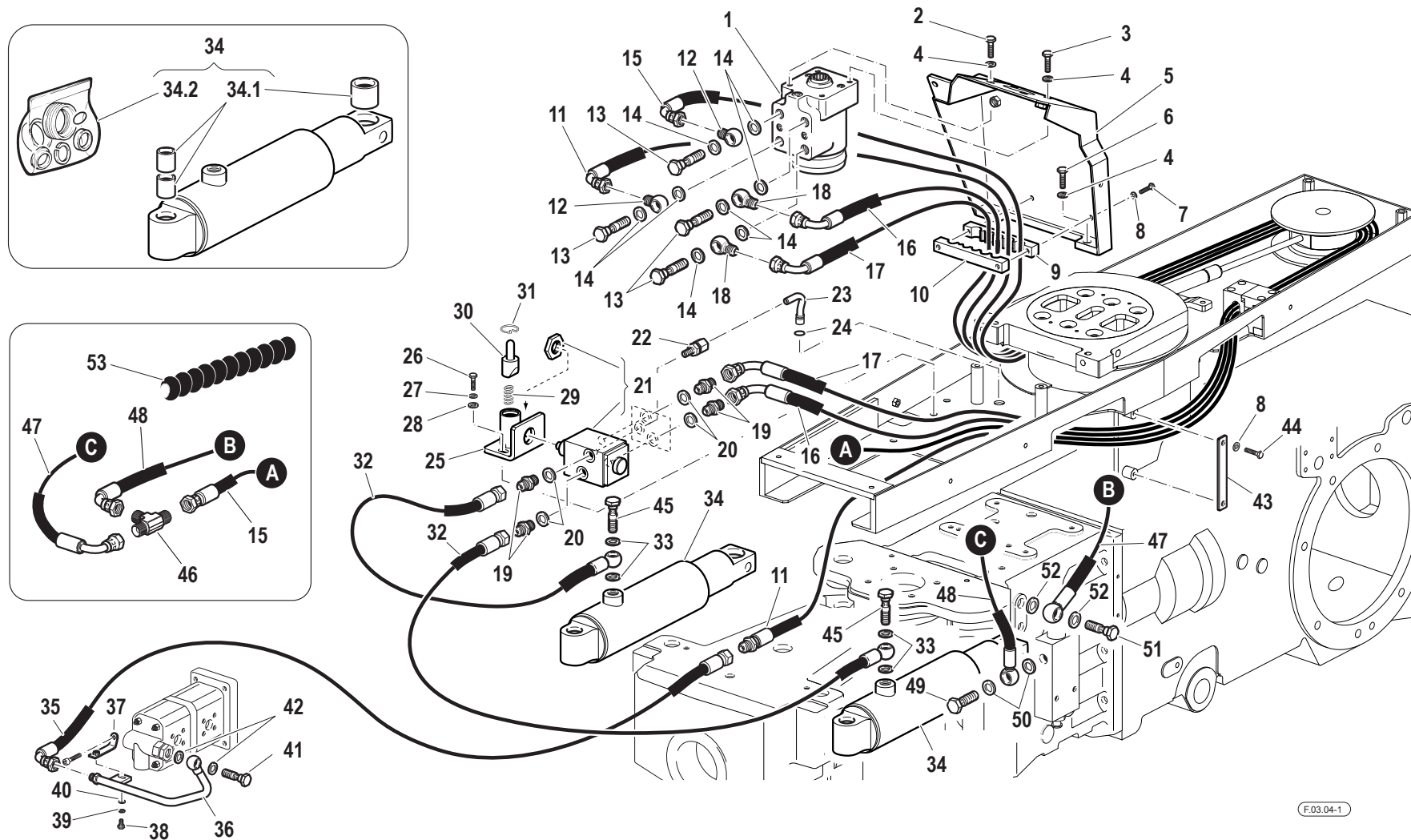

Pos.	Code	Q.ty	Description	Notes
1	58178954	1	HYDROSTEERING	
2	31112210	1	SCREW TE M10X20 UNI 5739	
3	31112219	3	SCREW TE M10X25 UNI 5739	
4	F0843755000	6	WASHER 10	
5	59074332	1	SUPPORT	
6	31112211	2	SCREW TE M10X30 UNI 5739	
7	31112092	2	SCREW TE M6X35 UNI 5739 8G	
8	F0843570000	2	WASHER 6	
9	56174481	1	COMB	
10	56174480	1	COMB	
11	58074836	1	FLEXIBLE HOSE	
12	F0842512000	2	PIPE FITTING	
13	F0843116000	4	PIPE FITTING 1/2	
14	F0824141000	8	COPPER WASHER 21x27/1,5	
15	58079433	1	FLEXIBLE HOSE	
16	58074891	1	FLEXIBLE HOSE	
17	58074740	1	FLEXIBLE HOSE	
18	F0835040030	2	PIPE FITTING	
19	F0835031010	4	NIPPLE	
20	F0843907000	4	COPPER WASHER 13,66x19/1,5	
21	P227332000000	1	D.A. VALVE	
22	58174547	1	NIPPLE	
23	59074546	1	EXHAUST	
24	F0803050000	1	O-RING	
25	59074482	1	PLATE	
26	31112150	2	SCREW TE M8X20 UNI 5739 8G	
27	F0843643060	2	WASHER 8	
28	31411084	2	WASHER 8,4x17	
29	58077413	1	SPRING	
30	56174485	1	CURSOR	
31	F0801163000	1	SEEGER RING	
32	58074734	2	FLEXIBLE HOSE	
33	F0843948000	4	COPPER WASHER 14,0x20/1,5	
34	58174305	2	CYLINDER	

SERIAL  
START  
**913641**

**STEERING HYDR. SYSTEM**

CODE REV

**F.03.04\_1\_40827**

# STEERING HYDR. SYSTEM

SERIAL START 913641

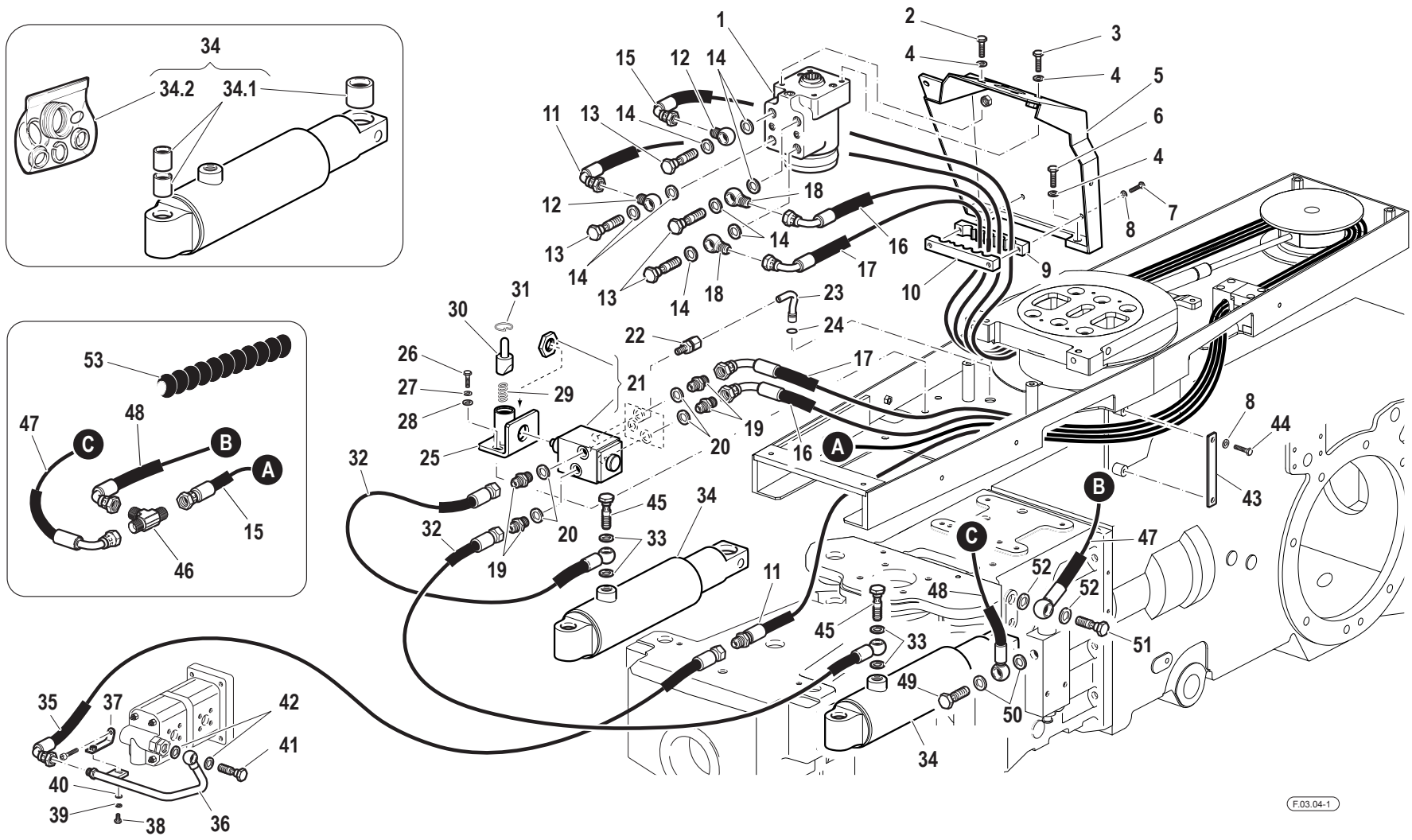



Pos.	Code	Q.ty	Description	Notes
34.1	59900340	1	BUSHINGS KIT	
34.2	58171737	1	GASKET SET	
35	58075248	1	FLEXIBLE HOSE	
36	59075224	1	PRESSURE PIPE	
37	59075225	1	FIXING BRACKET	
38	31112090	1	SCREW TE M6X16 UNI 5739 8G	
39	F0843570000	1	WASHER 6	
40	31411064	1	WASHER 6,4x12,5	
41	F0843110010	1	THREADED TERMINAL END M18x1,5	
42	F0824113000	2	COPPER WASHER 18X24/1,5	
43	56174494	1	SMALL PLATE	
44	F0862129000	2	SCREW M6X18 UNI 5739 8.8	
45	F0843109000	2	PIPE FITTING 14x1,5	
46	30000795	1	ADATT.3 VIE 3/8 OR:TI05060606	
47	58079435	1	PRESSURE HOSE	
48	58079434	1	PRESSURE HOSE	
49	F0843107000	1	PIPE FITTING GAS 1/4	
50	F0843907000	2	COPPER WASHER 13,66x19/1,5	
51	F0843109020	1	PIPE FITTING	
52	F0824110000	2	COPPER WASHER 3/8 GAS	
53	F0256909000	1	GUARD	

SERIAL  
START  
**913641**

**STEERING HYDR. SYSTEM**

CODE REV  
**F.03.04\_1\_40827**

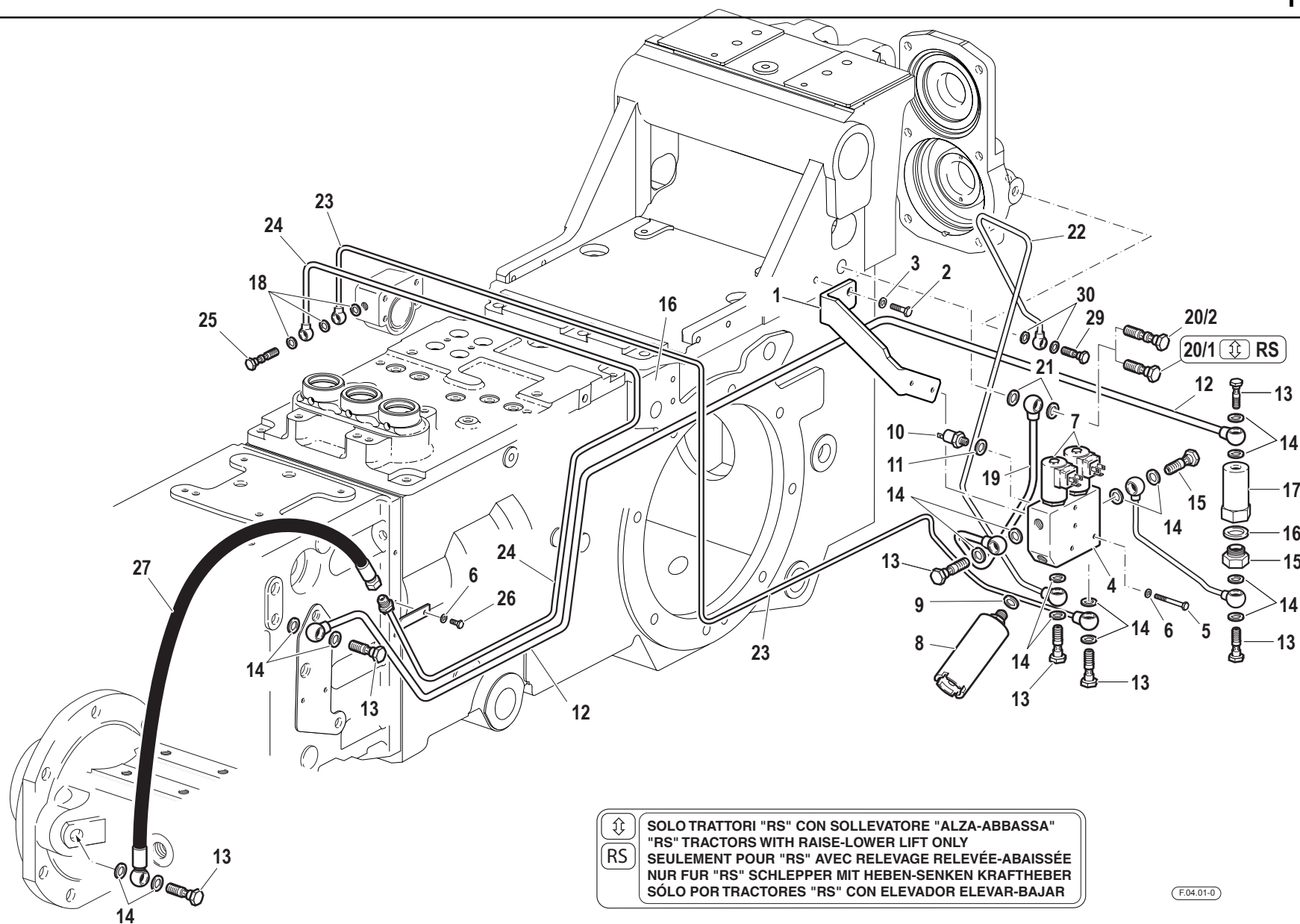

Pos.	Code	Q.ty	Description	Notes
1	56174665	1	SUPPORT	
2	31112150	2	SCREW TE M8X20 UNI 5739 8G	
3	F0843643060	2	WASHER 8	
4	56172749	1	SMALL BLOCK	
5	F0862345000	2	SCREW M6X40 UNI 5737	
6	F0843570000	3	WASHER 6	
7	58172463	2	ELECTRO VALVE	
8	59271011	1	UNIT	
9	F0843948000	1	COPPER WASHER 14,0x20/1,5	
10	58173399	1	PRESSURE SWITCH	
11	F0843841000	1	COPPER WASHER 12,0x18/1,5	
12	59075678	1	PRESSURE PIPE	
13	F0843107000	8	PIPE FITTING GAS 1/4	
14	F0843907000	16	COPPER WASHER 13,66x19/1,5	
15	58175677	1	HEAD	
16	F0824185000	1	COPPER WASHER 26X34X1,5	
17	58175676	1	BODY	
18	F0843771000	3	COPPER WASHER 10,0x16/1	
19	59074744	1	EXHAUST	
20/1	F0843109020	1	PIPE FITTING	
20/2	58170693	1	PIPE FITTING	
21	F0824110000	2	COPPER WASHER 3/8 GAS	
22	59075917	1	PRESSURE PIPE	
23	59074748	1	PRESSURE PIPE	
24	59074749	1	PRESSURE PIPE	
25	58174732	1	HOLLOW SCREW	
26	31111090	1	SCREW	
27	58074736	1	FLEXIBLE HOSE	
28	59075679	1	PIPE	
29	56178695	1	THREADED TERMINAL END	
30	P254124000000	2	WASHER	

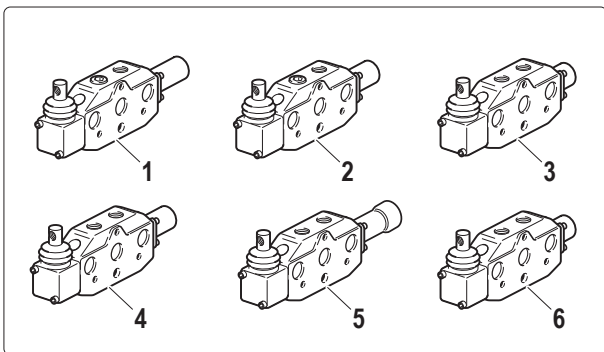

- VEDI TAVOLE GRUPPI...  
- SEE TABLES OF GROUPS...  
- VOIR TABLES GROUPES...  
- SIEHE GRUPPETAFFEL...  
- MIRAR TABLAS GRUPOS...

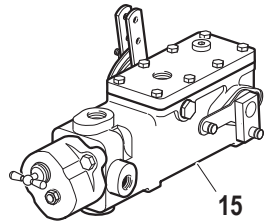
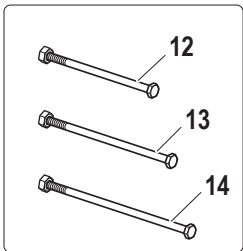
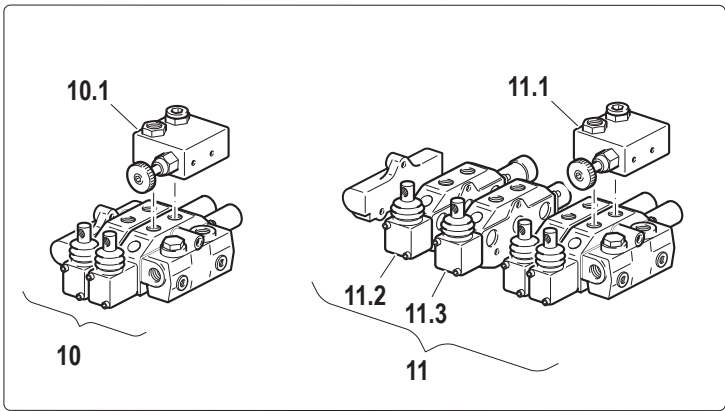
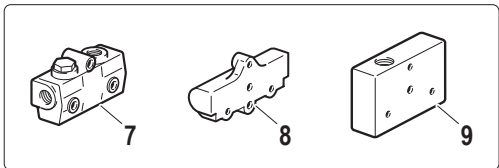

VEDI TAVOLE GRUPPO...  
SEE TABLES OF GROUP...  
VOIR TABLES GROUPE...  
SIEHE GRUPPETAFFEL...  
MIRAR TABLAS GRUPO...



Pos.	Code	Q.ty	Description	Notes
1	58172011	1	S.A. VALVE	
2	58172707	1	S.A. VALVE	
3	58172012	1	D.A. VALVE	
4	58172013	1	D.A. VALVE	
5	58172014	1	D.A. VALVE	
6	58172240	1	D.A. VALVE	
7	58172304	1	HEAD	
8	58172489	1	COVER	
9	58173361	1	COVER	
10	58171925	1	FLOATING DEVICE GROUP	
10.1	59900230	1	VALVE	
11	58174974	1	FLOATING DEVICE GROUP	
11.1	59900230	1	VALVE	
11.2	58172014	1	D.A. VALVE	
11.3	58172240	1	D.A. VALVE	
12	58172016	1	ROD	
13	58172017	1	ROD	
14	58172018	1	ROD	
15	58175191	1	DISTRIBUTOR	

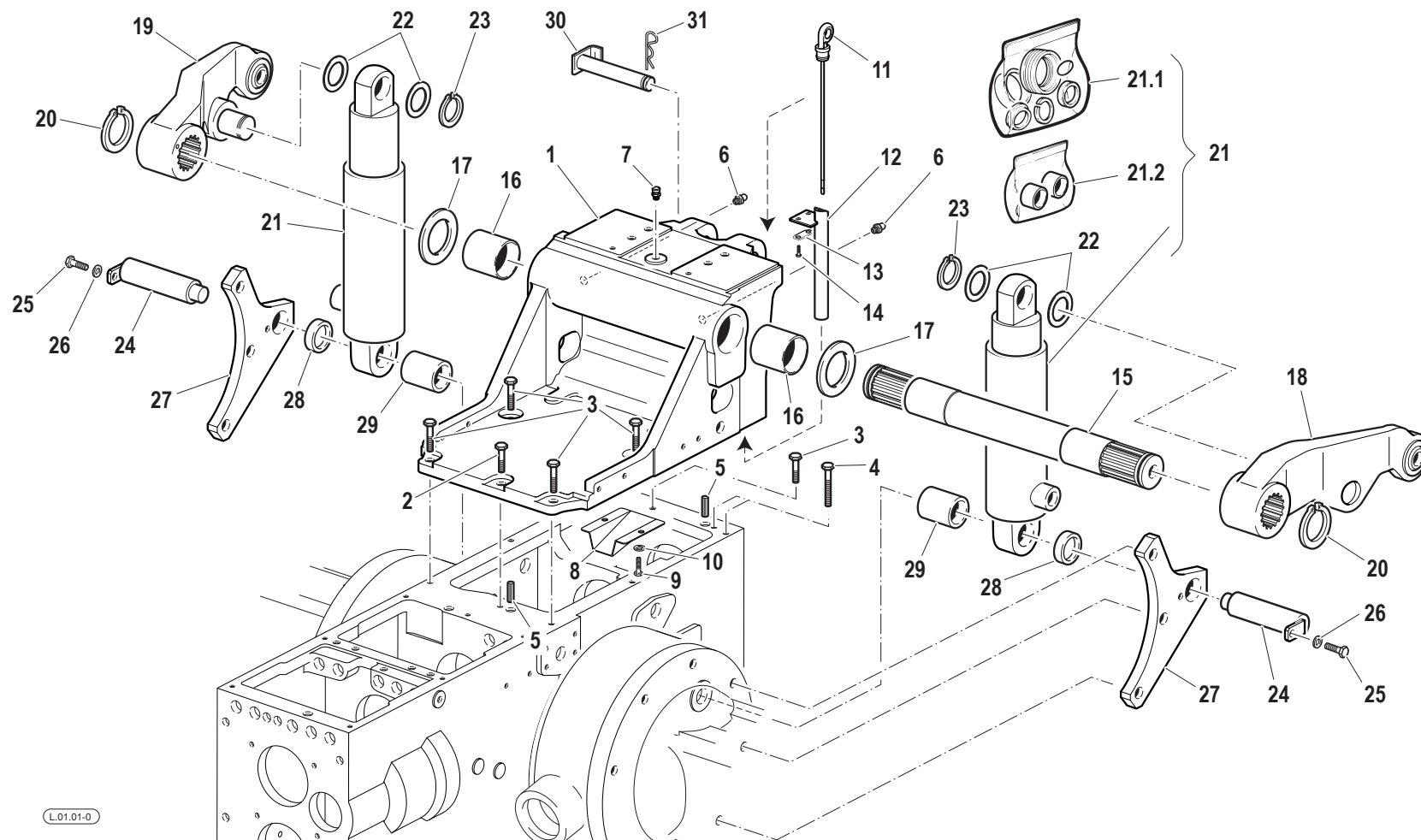

L.01.01-0

Pos.	Code	Q.ty	Description	Notes
1	51174315	1	SUPPORT	
2	31112219	1	SCREW TE M10X25 UNI 5739	
3	31112211	5	SCREW TE M10X30 UNI 5739	
4	F0863429000	4	SCREW M10X45 UNI 5737	
5	56570016	2	CYLINDRICAL PLUG	
6	F0826056000	1	LUBRICATOR M10 UNI 7663A	
7	58075603	1	PLUG	
8	56173638	1	GUARD	
9	31112149	2	SCREW TE M8X12 UNI 5739 8G	
10	F0843643060	2	WASHER 8	
11	58174581	1	OIL LEVEL ROD	
12	59076085	1	OIL PIPE	
13	52071702	1	CLAMPING PLATE	
14	31112082	2	SCREW TE M6X12 UNI 5739 8G	
15	56570284	1	SHAFT	
16	58170291	2	BUSHING	
17	56370288	2	SHIM	
18	59070289	1	LIFTING ARM	
19	59070290	1	RIGHT ARM	
20	F0801331050	2	SEEGER RING	
21	58170245	2	LIFTING CYLINDER	
21.1	58171537	1	GASKET SET	
21.2	58171536	1	BUSHINGS KIT	
22	56370282	4	SHIM	
23	F0801241010	2	SEEGER RING	
24	56370287	2	HINGE PIN	
25	31112150	2	SCREW TE M8X20 UNI 5739 8G	
26	F0843643060	2	WASHER 8	
27	56170283	2	BRACKET	
28	56170286	2	SPACER	
29	56170285	2	SPACER	
30	59078588	1	CONNECTING BOLT	
31	F0851486000	1	SPLIT PIN	

SERIAL

**RAISE/LOWER LIFT**

CODE REV

**L.01.01\_0\_40903**

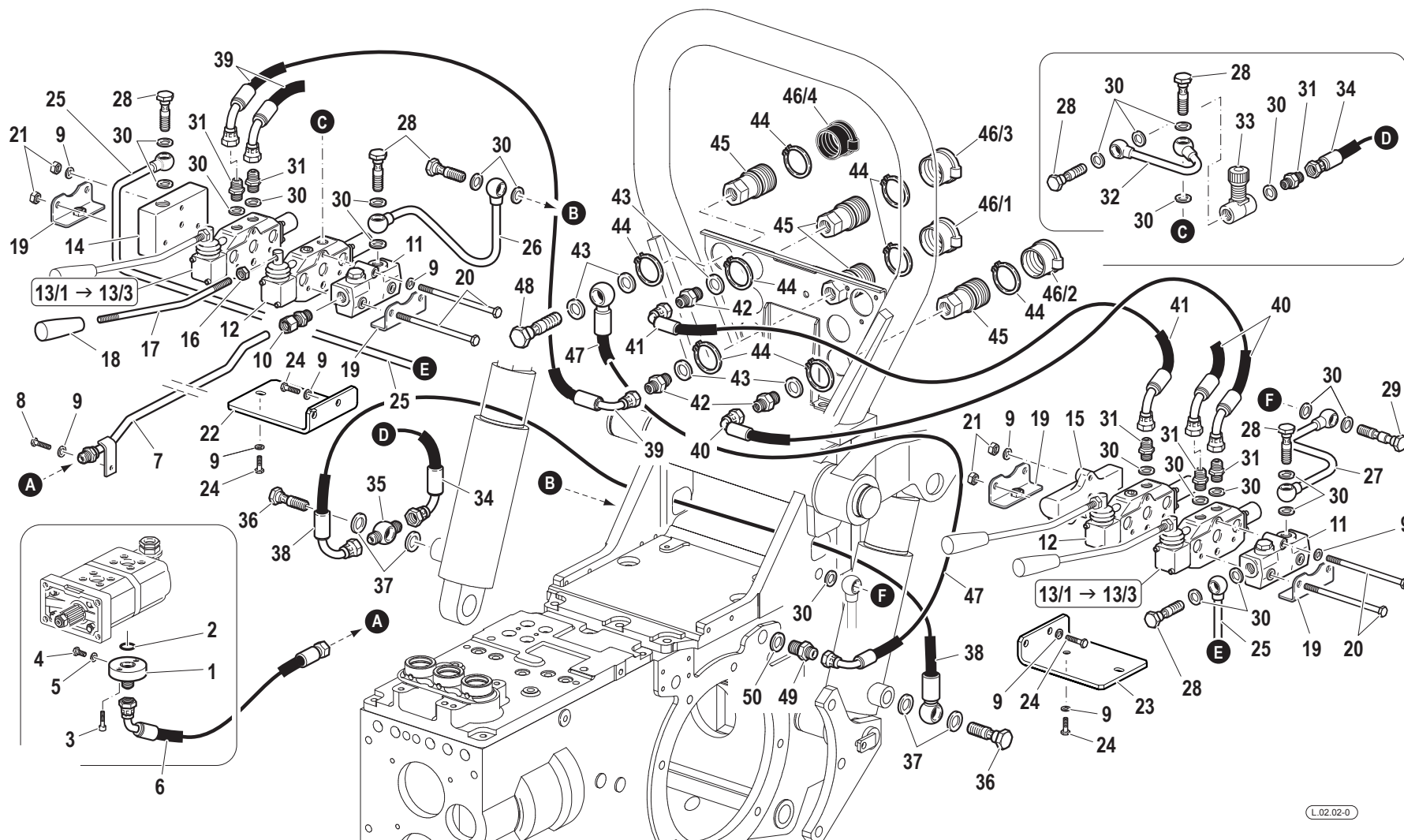



Pos.	Code	Q.ty	Description	Notes
1	F0825809000	1	PRESSURE PIPE CONNECTOR	
2	F0803185000	1	O-RING	
3	31152057	2	SCREW	
4	F0862462010	1	SCREW	
5	F0824022000	1	SPECIAL GASKET D.8,4X12/1	
6	58075247	1	FLEXIBLE HOSE	
7	59074754	1	PRESSURE PIPE	
8	31111151	1	SCREW TE M8X16 UNI 5739 8G	
9	F0843643060	13	WASHER 8	
10	58172015	1	PIPE FITTING	
11	58172304	2	HEAD	
12	58172011	2	S.A. VALVE	
13/1	58172012	2	D.A. VALVE	
13/2	58172013	2	D.A. VALVE	
13/3	58172014	2	D.A. VALVE	
14	58173361	1	COVER	
15	58172489	1	COVER	
16	31211100	4	NUT M10	
17	56170964	4	COMMAND LEVER	
18	F0837534010	4	GRIP	
19	59072057	4	FIXING BRACKET	
20	58172016	6	ROD	
21	31211080	12	NUT M8	
22	56174227	1	RIGHT YOKE	
23	56174201	1	LEFT BRACKET	
24	31112150	8	SCREW TE M8X20 UNI 5739 8G	
25	59075037	1	PIPE	
26	59074759	1	OIL PIPE	
27	59075039	1	EXHAUST	
28	F0843109020	7	PIPE FITTING	
29	58170693	1	PIPE FITTING	
30	F0824110000	23	COPPER WASHER 3/8 GAS	
31	30000197	6	NIPPLE	
32	59075360	1	PRESSURE PIPE	

SERIAL

**FREE DISCHARGE CONTROL VALVES VERSION**

CODE REV

**L.02.02\_0\_40987**

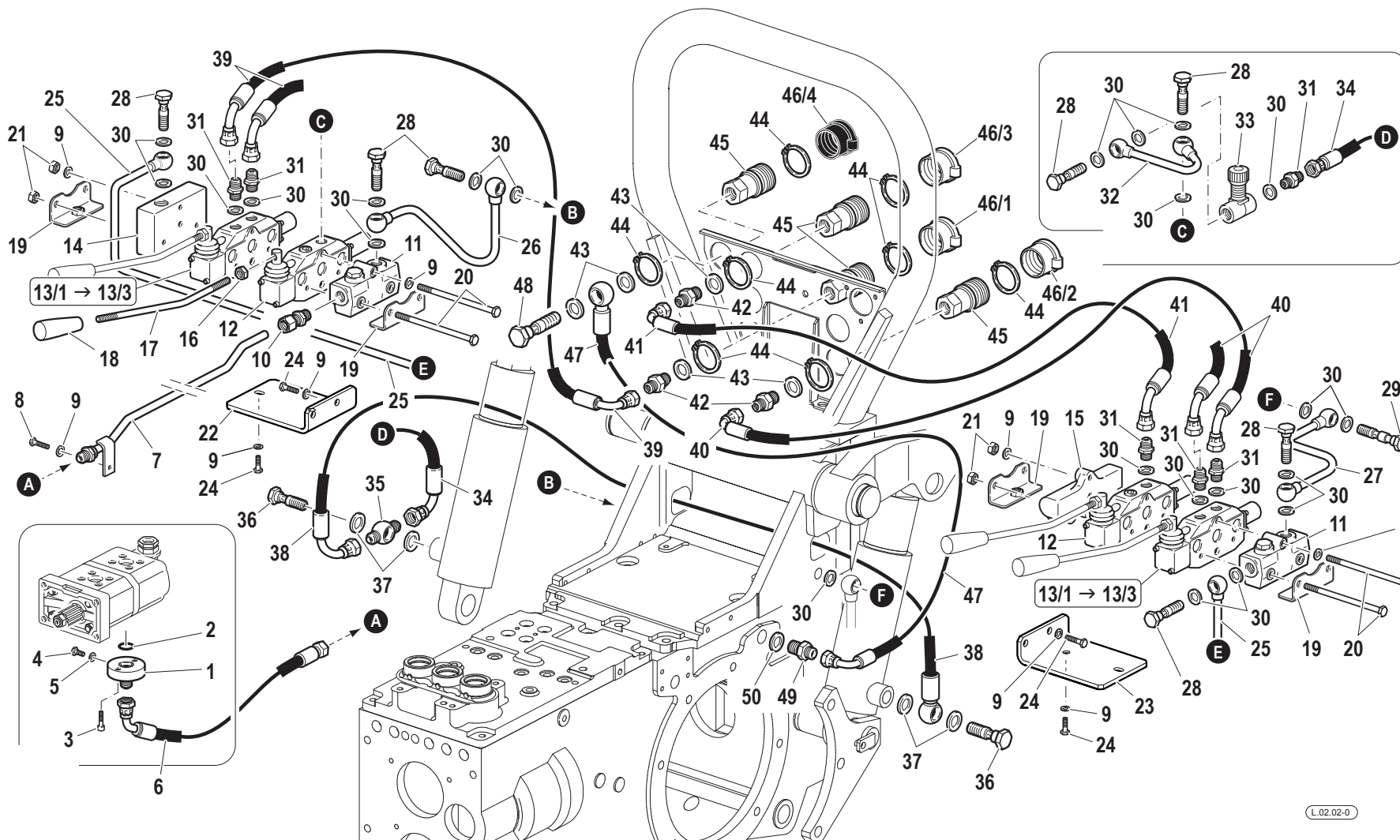

Pos.	Code	Q.ty	Description	Notes
33	P241171000000	1	VALVE	
34	58075358	1	FLEXIBLE HOSE	
35	58170512	1	EYELET	
36	F0843110010	2	THREADED TERMINAL END M18x1,5	
37	F0824113000	4	COPPER WASHER 18X24/1,5	
38	58070513	1	FLEXIBLE HOSE	
39	58075080	2	FLEXIBLE HOSE	
40	58074958	2	FLEXIBLE HOSE	
41	58075226	1	FLEXIBLE HOSE	
42	F0835037000	5	NIPPLE	
43	F0824141000	5	COPPER WASHER 21x27/1,5	
44	F0801282000	12	SEEGER RING E 38 UNI 7435	
45	F0825980030	6	COUPLING	
46/1	F0852550010	2	GUARD	
46/2	F0852550020	2	GUARD	
46/3	F0852550030	1	GUARD	
46/4	F0852550040	1	GUARD	
47	58075082	1	FLEXIBLE HOSE	
48	F0843116000	1	PIPE FITTING 1/2	
49	58175083	1	NIPPLE	
50	F0844273090	1	GASKET 22X28X1,5 CU 99,5	

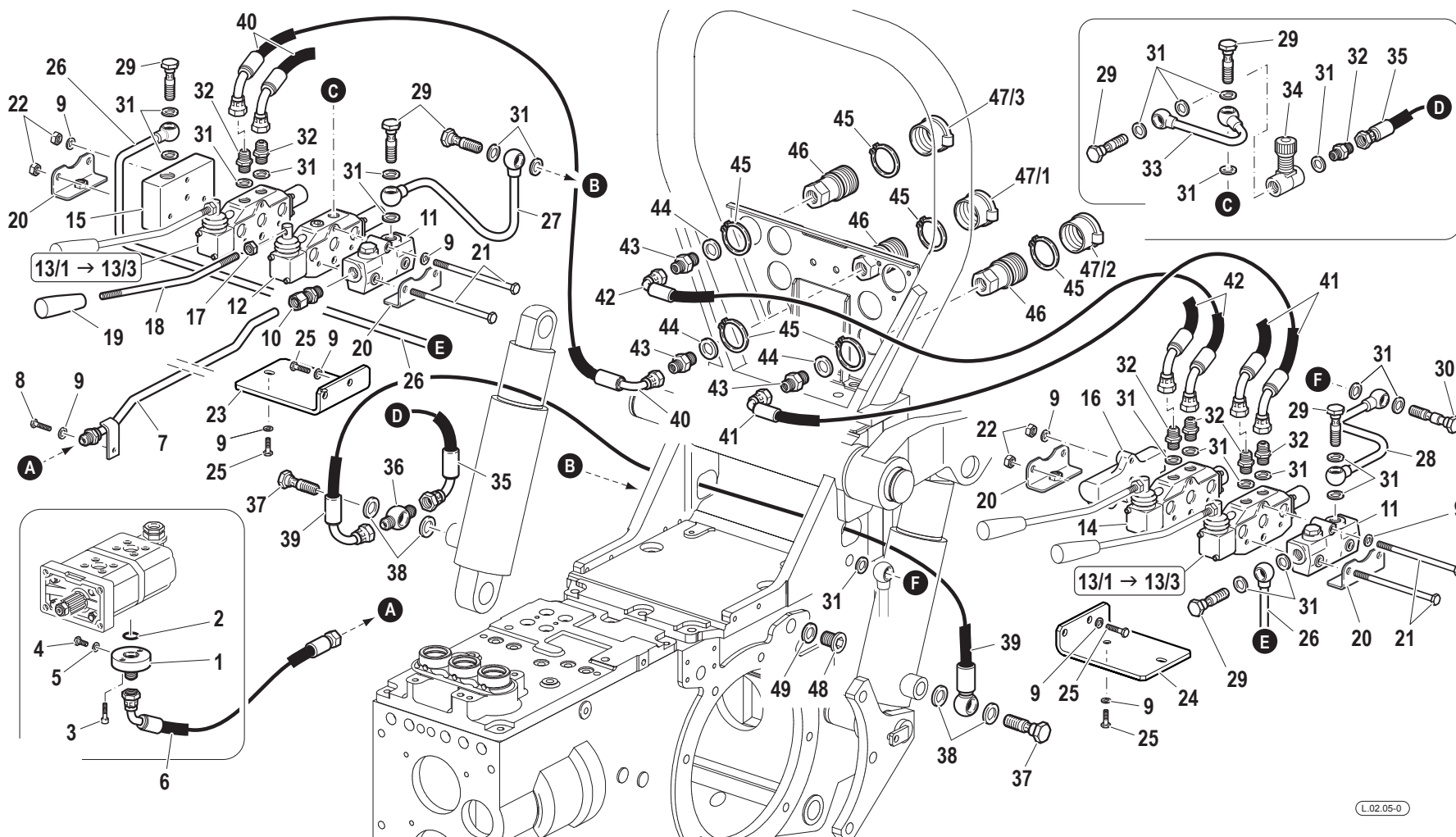

Pos.	Code	Q.ty	Description	Notes
1	F0825809000	1	PRESSURE PIPE CONNECTOR	
2	F0803185000	1	O-RING	
3	31152057	2	SCREW	
4	F0862462010	1	SCREW	
5	F0824022000	1	SPECIAL GASKET D.8,4X12/1	
6	58075247	1	FLEXIBLE HOSE	
7	59074754	1	PRESSURE PIPE	
8	31111151	1	SCREW TE M8X16 UNI 5739 8G	
9	F0843643060	13	WASHER 8	
10	58172015	1	PIPE FITTING	
11	58172304	2	HEAD	
12	58172011	1	S.A. VALVE	
13/1	58172012	2	D.A. VALVE	
13/2	58172013	2	D.A. VALVE	
13/3	58172014	2	D.A. VALVE	
14	58172012	1	D.A. VALVE	
15	58173361	1	COVER	
16	58172489	1	COVER	
17	31211100	4	NUT M10	
18	56170964	4	COMMAND LEVER	
19	F0837534010	4	GRIP	
20	59072057	4	FIXING BRACKET	
21	58172016	6	ROD	
22	31211080	6	NUT M8	
23	56174227	1	RIGHT YOKE	
24	56174201	1	LEFT BRACKET	
25	31112150	8	SCREW TE M8X20 UNI 5739 8G	
26	59075037	1	PIPE	
27	59074759	1	OIL PIPE	
28	59075039	1	EXHAUST	
29	F0843109020	7	PIPE FITTING	
30	58170693	1	PIPE FITTING	
31	F0824110000	24	COPPER WASHER 3/8 GAS	
32	30000197	7	NIPPLE	

SERIAL

**CONTROL VALVES WITHOUT FREE DISCHARGE VERSION**

CODE REV

**L.02.05\_0\_41145**

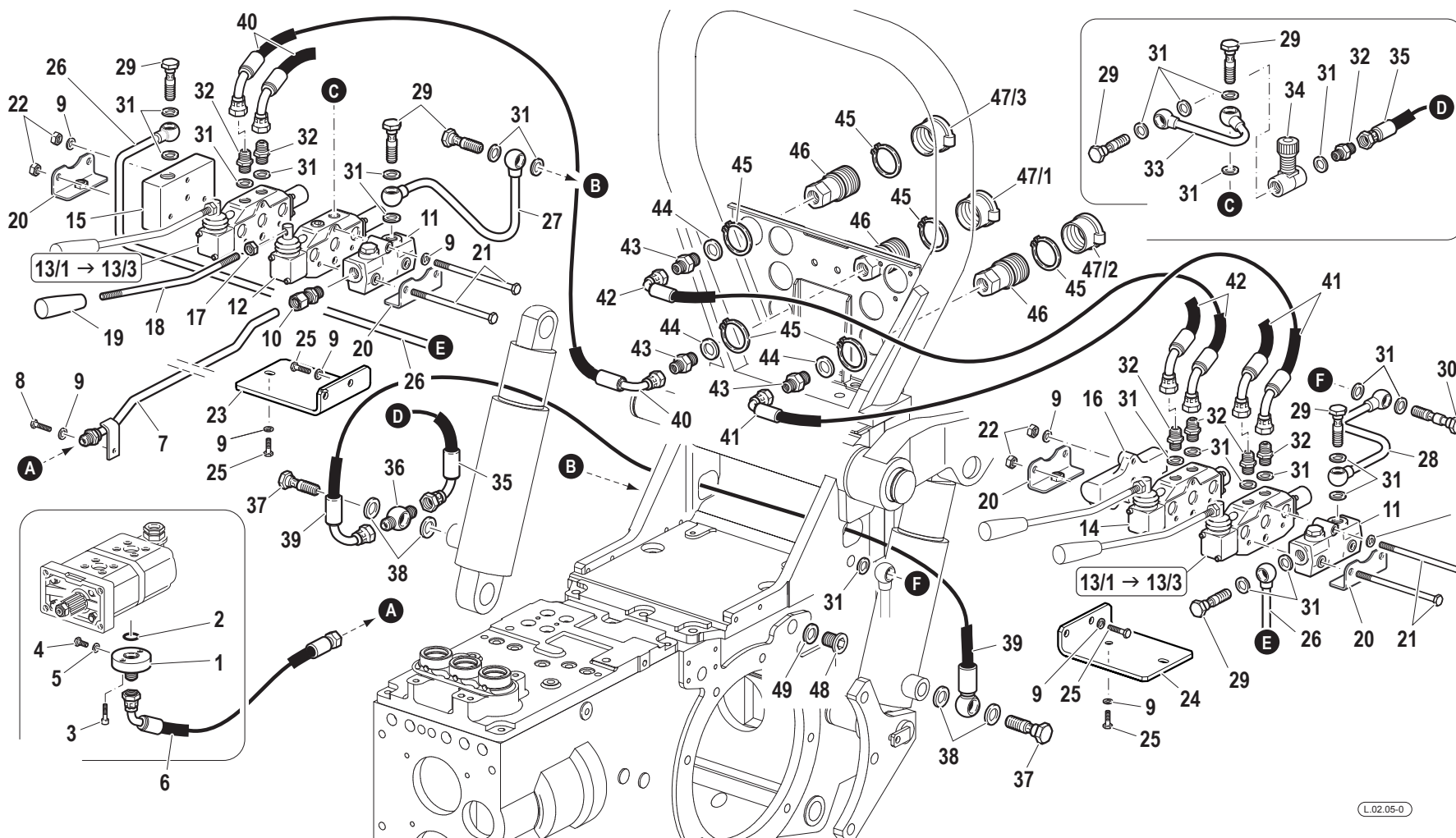

Pos.	Code	Q.ty	Description	Notes
33	59075360	1	PRESSURE PIPE	
34	P241171000000	1	VALVE	
35	58075358	1	FLEXIBLE HOSE	
36	58170512	1	EYELET	
37	F0843110010	2	THREADED TERMINAL END M18x1,5	
38	F0824113000	4	COPPER WASHER 18X24/1,5	
39	58070513	1	FLEXIBLE HOSE	
40	58075080	2	FLEXIBLE HOSE	
41	58074958	2	FLEXIBLE HOSE	
42	58075226	2	FLEXIBLE HOSE	
43	F0835037000	6	NIPPLE	
44	F0824141000	6	COPPER WASHER 21x27/1,5	
45	F0801282000	12	SEEGER RING E 38 UNI 7435	
46	F0825980030	6	COUPLING	
47/1	F0852550010	2	GUARD	
47/2	F0852550020	2	GUARD	
47/3	F0852550030	2	GUARD	
48	56370081	1	PLUG	
49	F0844273090	1	GASKET 22X28X1,5 CU 99,5	

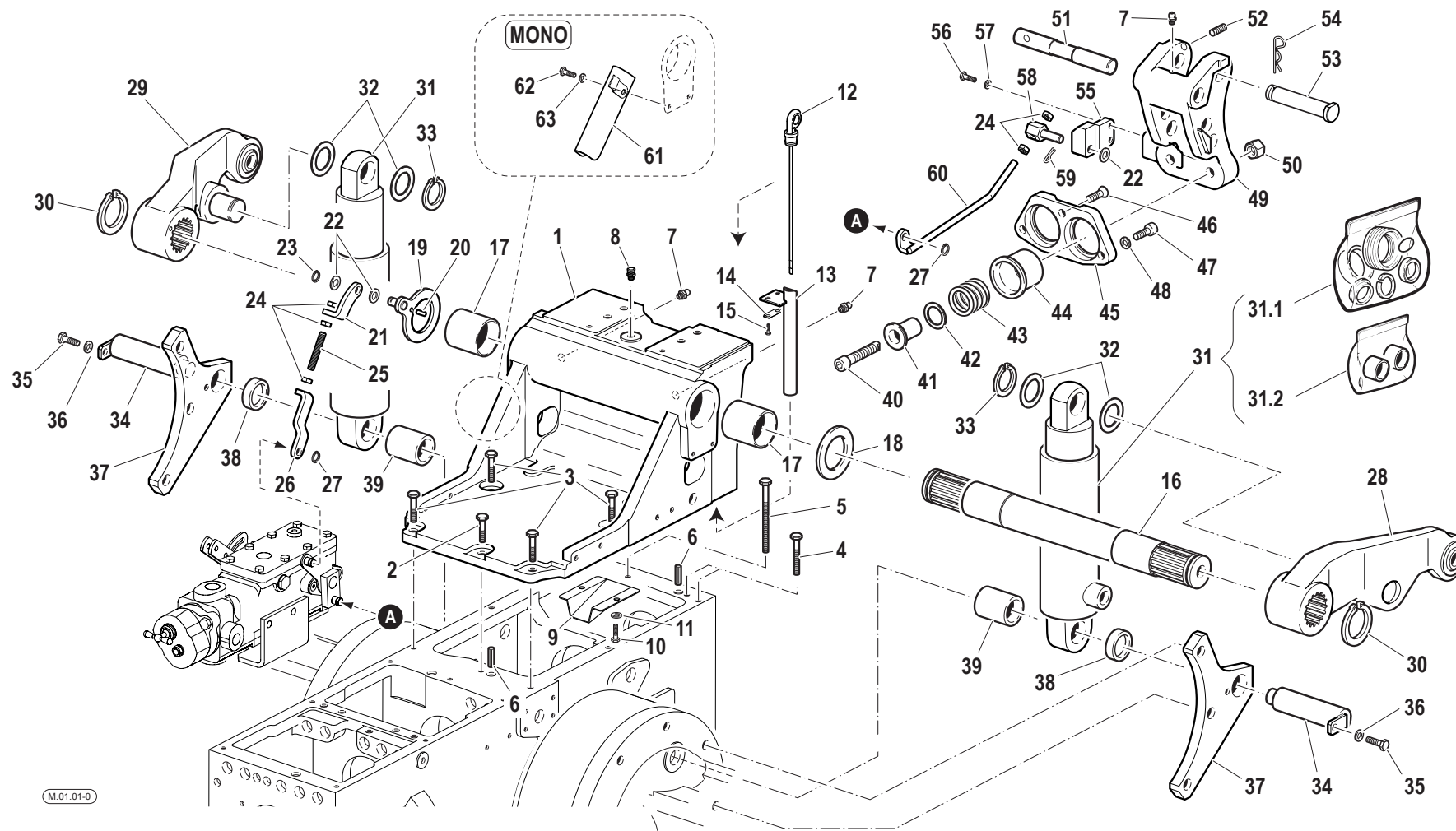



Pos.	Code	Q.ty	Description	Notes
1	51174047	1	SUPPORT	
2	31112219	1	SCREW TE M10X25 UNI 5739	
3	31112211	4	SCREW TE M10X30 UNI 5739	
4	F0863429000	4	SCREW M10X45 UNI 5737	
5	31112217	1	SCREW TE M10X80 UNI 5737	
6	56570016	2	CYLINDRICAL PLUG	
7	F0826056000	3	LUBRICATOR M10 UNI 7663A	
8	58075603	1	PLUG	
9	56173638	1	GUARD	
10	31112149	2	SCREW TE M8X12 UNI 5739 8G	
11	F0843643060	2	WASHER 8	
12	58174581	1	OIL LEVEL ROD	
13	59076085	1	OIL PIPE	
14	52071702	1	CLAMPING PLATE	
15	31112082	2	SCREW TE M6X12 UNI 5739 8G	
16	56570284	1	SHAFT	
17	58170291	2	BUSHING	
18	56370288	1	SHIM	
19	59075148	1	SHIM	
20	56570506	1	PIN	
21	56375147	1	BRACKET	
22	31411104	3	WASHER 10,5x18	
23	F0801050000	1	SEEGER RING	
24	F0814569000	5	NUT	
25	56375146	1	GRAIN	
26	56075145	1	BRACKET	
27	35211070	2	SEEGER RING	
28	59070289	1	LIFTING ARM	
29	59070290	1	RIGHT ARM	
30	F0801331050	2	SEEGER RING	
31	58170245	2	LIFTING CYLINDER	
31.1	58171537	1	GASKET SET	
31.2	58171536	1	BUSHINGS KIT	
32	56370282	4	SHIM	

SERIAL

**POSITION AND DRAFT CONTROL LIFT**

CODE REV

**M.01.01\_0\_41199**

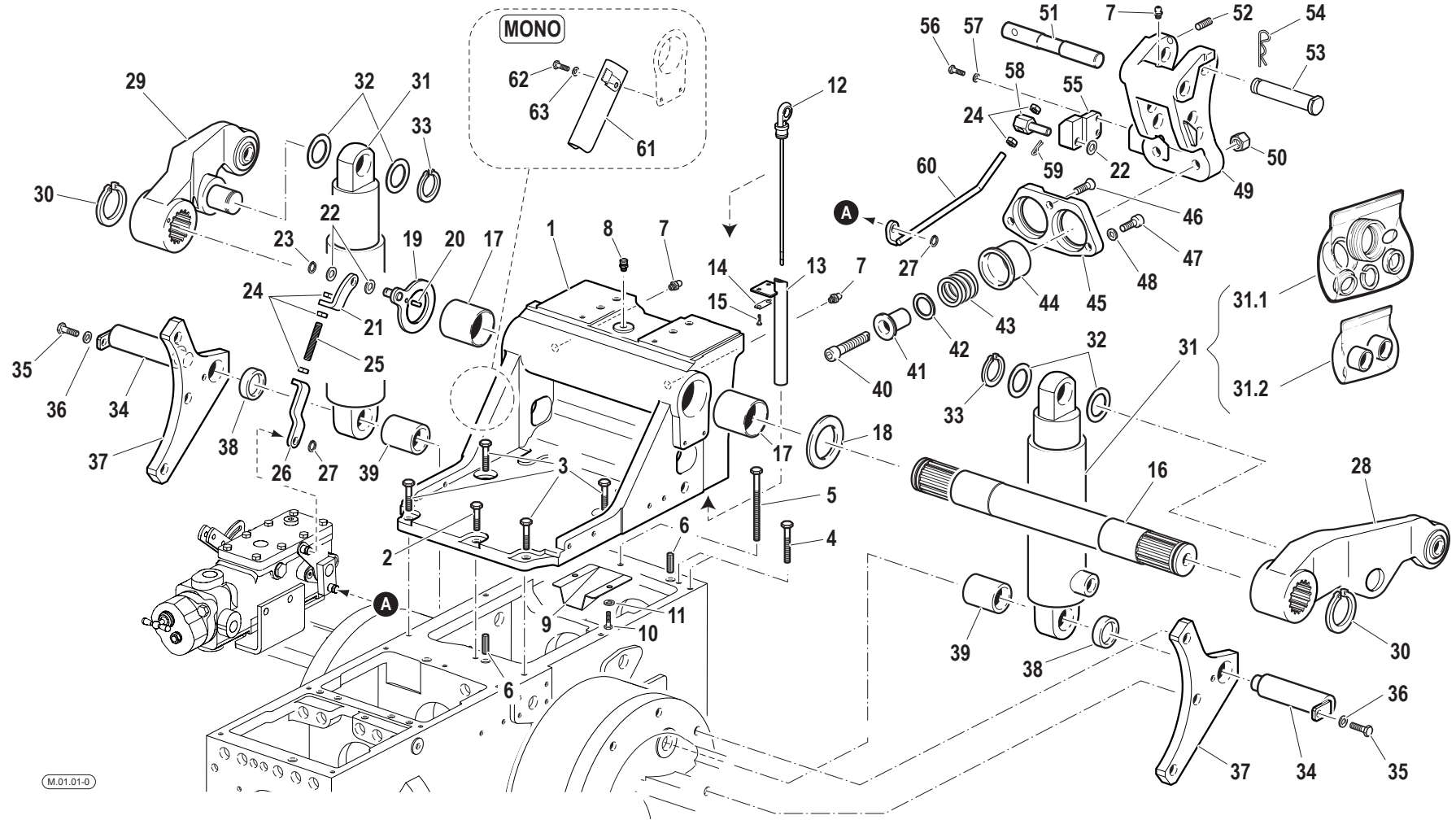

Pos.	Code	Q.ty	Description	Notes
33	F0801241010	2	SEEGER RING	
34	56370287	2	HINGE PIN	
35	31112150	2	SCREW TE M8X20 UNI 5739 8G	
36	F0843643060	2	WASHER 8	
37	56170283	2	BRACKET	
38	56170286	2	SPACER	
39	56170285	2	SPACER	
40	50973415	2	SCREW	
41	56073414	2	GUIDE	
42	56373426	1	SHIM	
42	56373427	1	SHIM	
42	56373428	1	SHIM	
42	58025869	1	SHIM	
43	58073411	2	SPRING	
44	56073413	2	SLEEVE	
45	56073416	1	FLANGE	
46	F0863208050	1	SCREW M10X20 UNI 5933	
47	31152097	2	SCREW TCEI M10X30 UNI 5931	
48	F0843755000	2	WASHER 10	
49	51173371	1	THREE-POINT LINKAGE	
50	31241121	2	SELFLOCK NUT M12	
51	56374574	1	CONNECTING BOLT	
52	F0862593050	1	SCREW M8X20 UNI 5927	
53	56373436	1	PIN	
54	F0851486000	1	SPLIT PIN	
55	59075140	1	SMALL BLOCK	
56	31112093	2	SCREW TE M6X20	
57	F0843570000	2	WASHER 6	
58	56075143	1	HINGE PIN	
59	34110030	1	SPLIT PIN	
60	59075137	1	ROD	
61	59075178	1	CABLE BARRIER RAIL	
62	31111091	1	SCREW E M6X14 UNI 5739 8G	
63	F0843570000	1	WASHER 6	

SERIAL

**POSITION AND DRAFT CONTROL LIFT**

CODE REV

**M.01.01\_0\_41199**

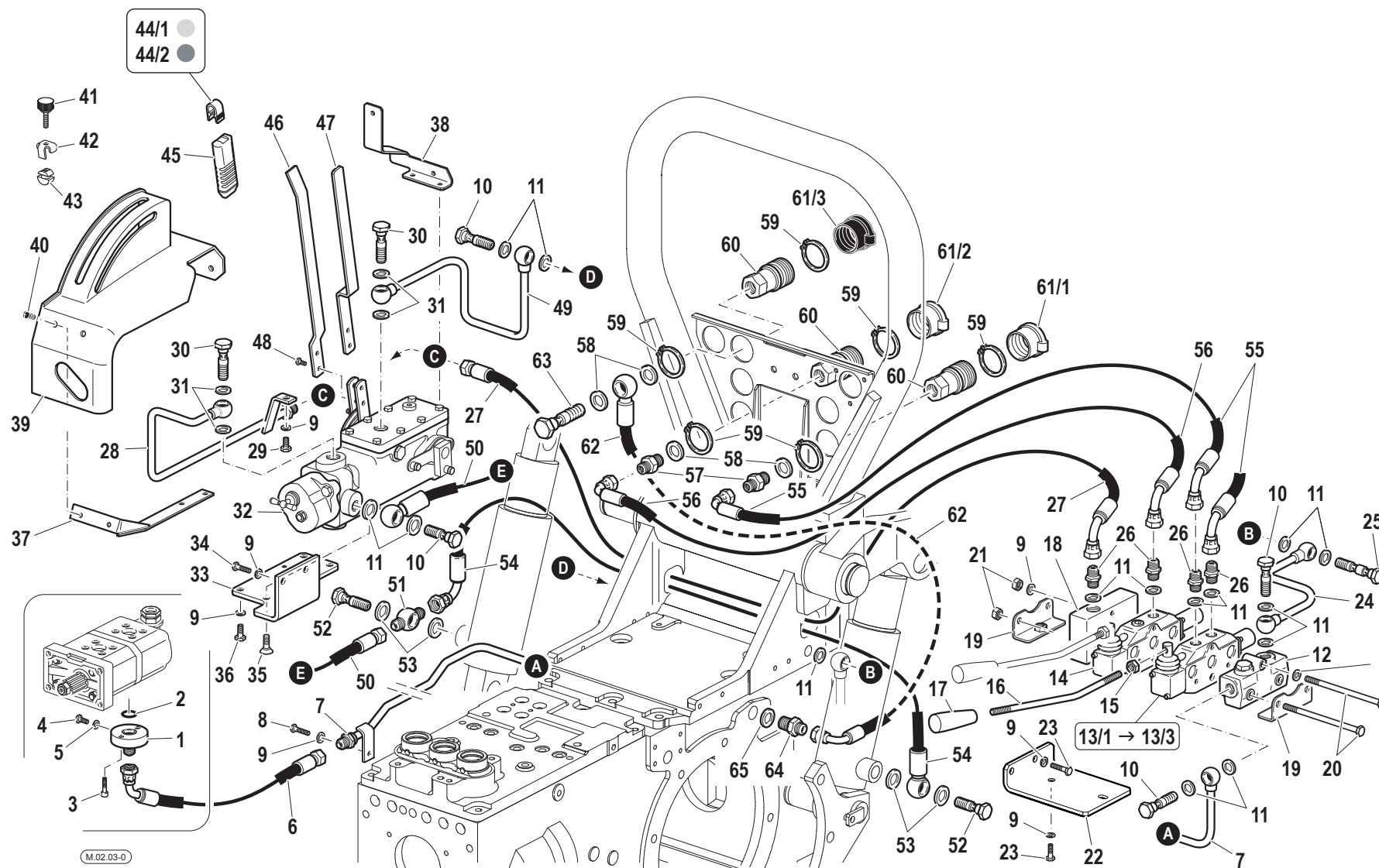

Pos.	Code	Q.ty	Description	Notes
1	F0825809000	1	PRESSURE PIPE CONNECTOR	
2	F0803185000	1	O-RING	
3	31152057	2	SCREW	
4	F0862462010	1	SCREW	
5	F0824022000	1	SPECIAL GASKET D.8,4X12/1	
6	58075247	1	FLEXIBLE HOSE	
7	59075169	1	PRESSURE PIPE	
8	31111151	1	SCREW TE M8X16 UNI 5739 8G	
9	F0843643060	14	WASHER 8	
10	F0843109020	4	PIPE FITTING	
11	F0824110000	15	COPPER WASHER 3/8 GAS	
12	58172304	1	HEAD	
13/1	58172012	1	D.A. VALVE	
13/2	58172013	1	D.A. VALVE	
13/3	58172014	1	D.A. VALVE	
14	58172011	1	S.A. VALVE	
15	31211100	2	NUT M10	
16	56170964	2	COMMAND LEVER	
17	F0837534010	2	GRIP	
18	58173361	1	COVER	
19	59072057	2	FIXING BRACKET	
20	58172016	3	ROD	
21	31211080	3	NUT M8	
22	56174201	1	LEFT BRACKET	
23	31112150	4	SCREW TE M8X20 UNI 5739 8G	
24	59075039	1	EXHAUST	
25	F0843110010	1	THREADED TERMINAL END M18x1,5	
26	30000197	4	NIPPLE	
27	58075159	1	FLEXIBLE HOSE	
28	59075979	1	PRESSURE PIPE	
29	31112149	1	SCREW TE M8X12 UNI 5739 8G	
30	F0843116000	2	PIPE FITTING 1/2	
31	F0824141000	4	COPPER WASHER 21x27/1,5	
32	58175191	1	DISTRIBUTOR	

SERIAL

**FREE DISCHARGE CONTROL VALVES VERSION**

CODE REV

**M.02.03\_0\_41409**

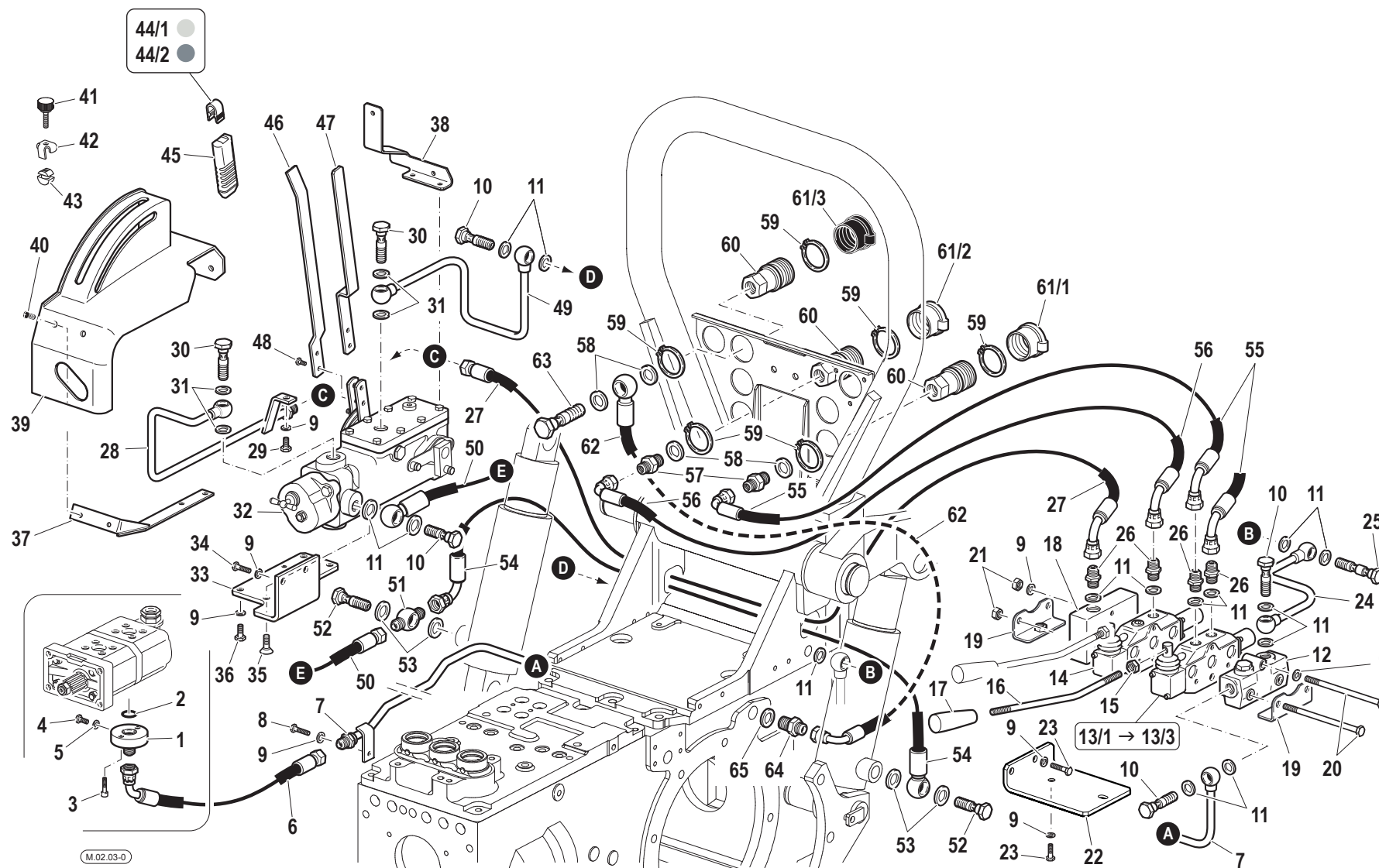

Pos.	Code	Q.ty	Description	Notes
33	56075161	1	FIXING BRACKET	
34	31112150	2	SCREW TE M8X20 UNI 5739 8G	
35	F0862481000	1	SCREW M8x16 UNI 5933	
36	31111151	3	SCREW TE M8X16 UNI 5739 8G	
37	59075254	1	FIXING BRACKET	
38	56075252	1	FIXING BRACKET	
39	57375195	1	COVER	
40	F0861973000	4	SCREW M6X10 COMBI	
41	58177761	1	KNOB	
42	56075197	1	CLIP	
43	56077760	1	SMALL BLOCK	
44/1	58175211	1	INSERT	
44/2	58175188	1	INSERT	
45	58175187	2	KNOB	
46	56075185	1	COMMAND LEVER	
47	56075186	1	COMMAND LEVER	
48	31112090	4	SCREW TE M6X16 UNI 5739 8G	
49	59075171	1	EXHAUST	
50	58075160	1	FLEXIBLE HOSE	
51	58170512	1	EYELET	
52	F0843110010	2	THREADED TERMINAL END M18x1,5	
53	F0824113000	4	COPPER WASHER 18X24/1,5	
54	58070513	1	FLEXIBLE HOSE	
55	58074958	2	FLEXIBLE HOSE	
56	58075226	1	FLEXIBLE HOSE	
57	F0835037000	3	NIPPLE	
58	F0824141000	5	COPPER WASHER 21x27/1,5	
59	F0801282000	8	SEEGER RING E 38 UNI 7435	
60	F0825980030	4	COUPLING	
61/1	F0852550020	2	GUARD	
61/2	F0852550030	1	GUARD	
61/3	F0852550040	1	GUARD	
62	58075082	1	FLEXIBLE HOSE	
63	F0843116000	1	PIPE FITTING 1/2	

SERIAL

**FREE DISCHARGE CONTROL VALVES VERSION**

CODE REV

**M.02.03\_0\_41409**

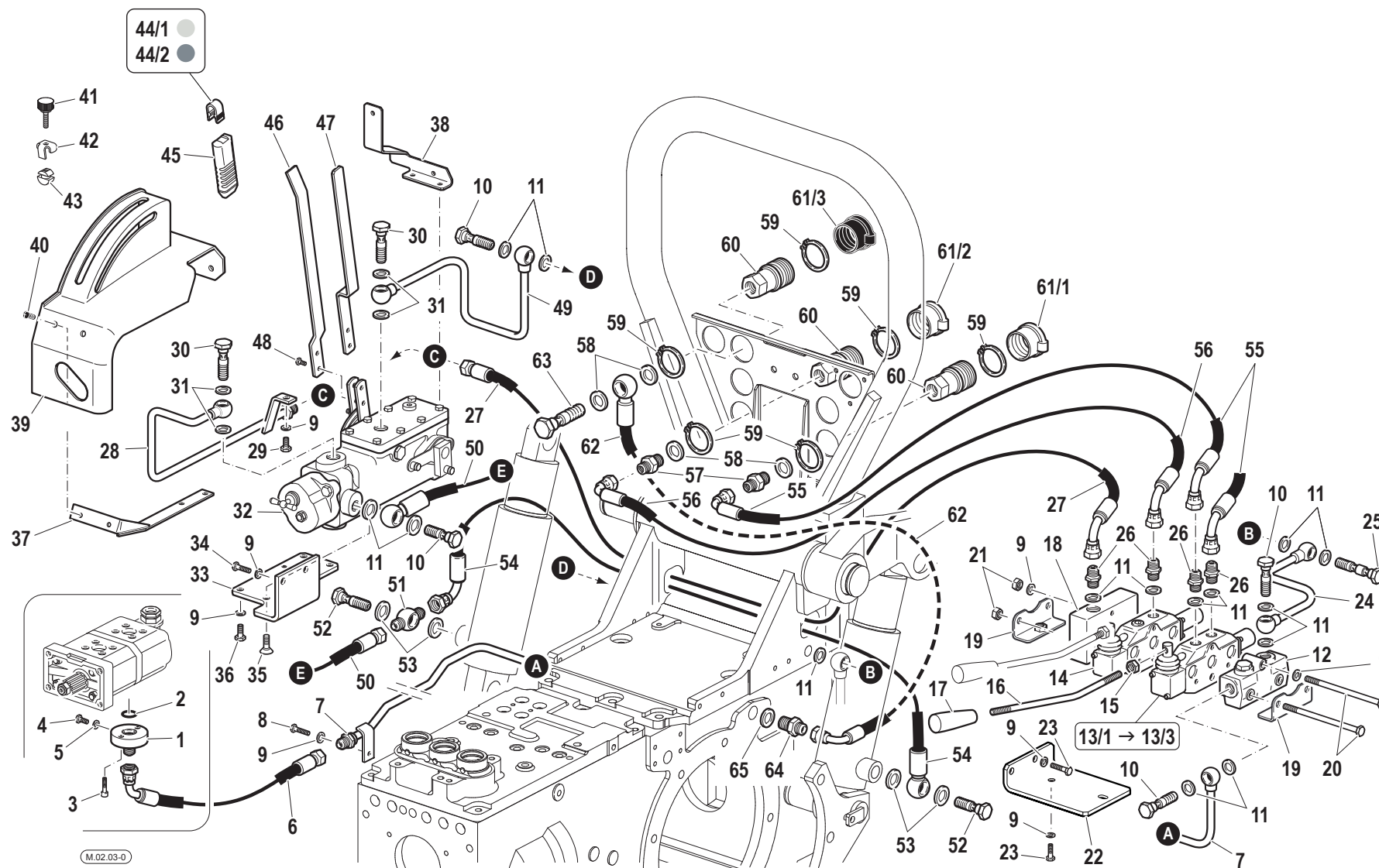



Pos.	Code	Q.ty	Description	Notes
64	58175083	1	NIPPLE	
65	F0844273090	1	GASKET 22X28X1,5 CU 99,5	

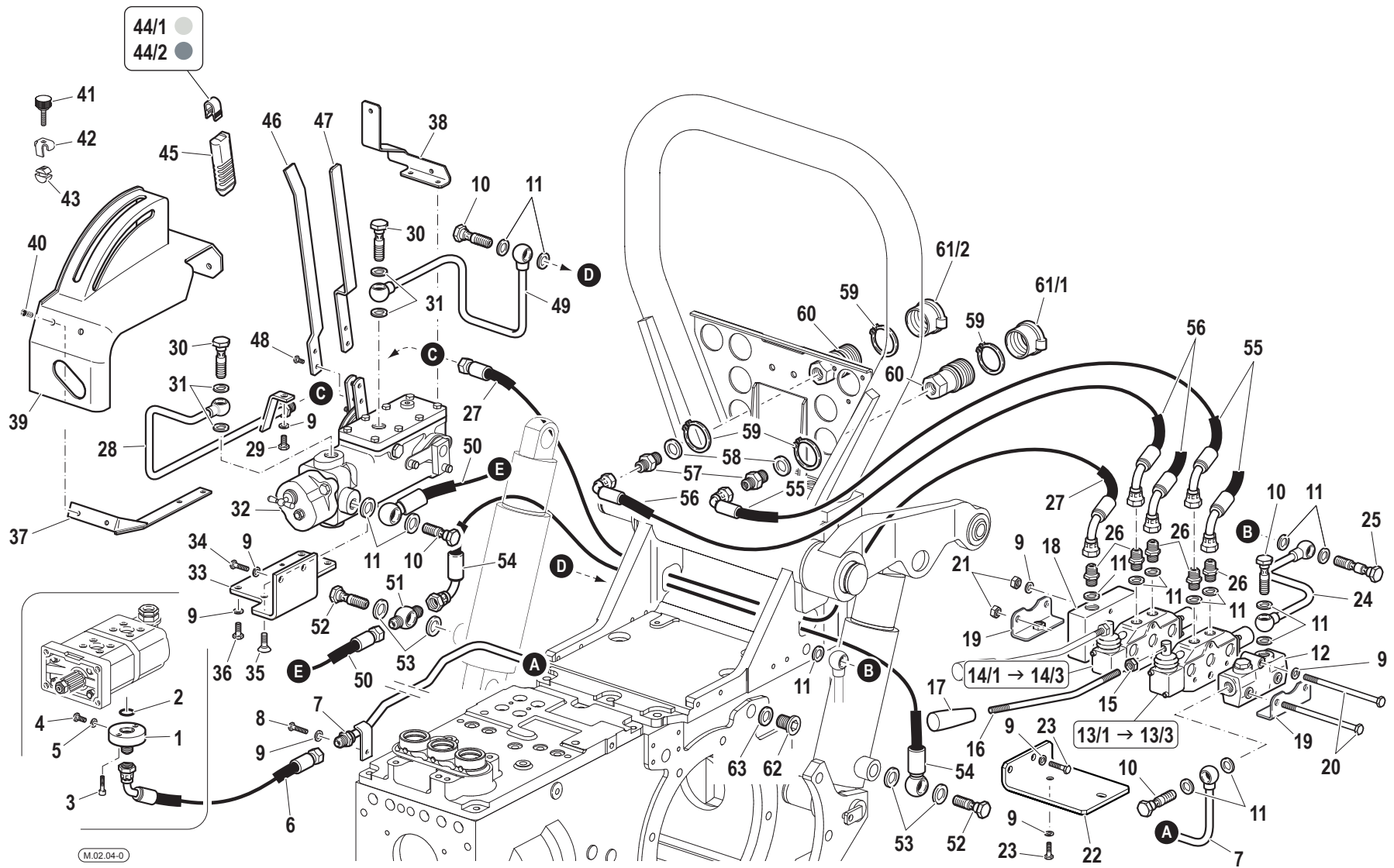

Pos.	Code	Q.ty	Description	Notes
1	F0825809000	1	PRESSURE PIPE CONNECTOR	
2	F0803185000	1	O-RING	
3	31152057	2	SCREW	
4	F0862462010	1	SCREW	
5	F0824022000	1	SPECIAL GASKET D.8,4X12/1	
6	58075247	1	FLEXIBLE HOSE	
7	59075169	1	PRESSURE PIPE	
8	31111151	1	SCREW TE M8X16 UNI 5739 8G	
9	F0843643060	14	WASHER 8	
10	F0843109020	4	PIPE FITTING	
11	F0824110000	15	COPPER WASHER 3/8 GAS	
12	58172304	1	HEAD	
13/1	58172012	1	D.A. VALVE	
13/2	58172013	1	D.A. VALVE	
13/3	58172014	1	D.A. VALVE	
14/1	58172012	1	D.A. VALVE	
14/2	58172013	1	D.A. VALVE	
14/3	58172014	1	D.A. VALVE	
15	31211100	2	NUT M10	
16	56170964	2	COMMAND LEVER	
17	F0837534010	2	GRIP	
18	58173361	1	COVER	
19	59072057	2	FIXING BRACKET	
20	58172016	3	ROD	
21	31211080	3	NUT M8	
22	56174201	1	LEFT BRACKET	
23	31112150	4	SCREW TE M8X20 UNI 5739 8G	
24	59075039	1	EXHAUST	
25	F0843110010	1	THREADED TERMINAL END M18x1,5	
26	30000197	4	NIPPLE	
27	58075159	1	FLEXIBLE HOSE	
28	59075979	1	PRESSURE PIPE	
29	31112149	1	SCREW TE M8X12 UNI 5739 8G	
30	F0843116000	2	PIPE FITTING 1/2	

SERIAL

**CONTROL VALVES WITHOUT FREE DISCHARGE VERSION**

CODE REV

**M.02.04\_0\_41480**

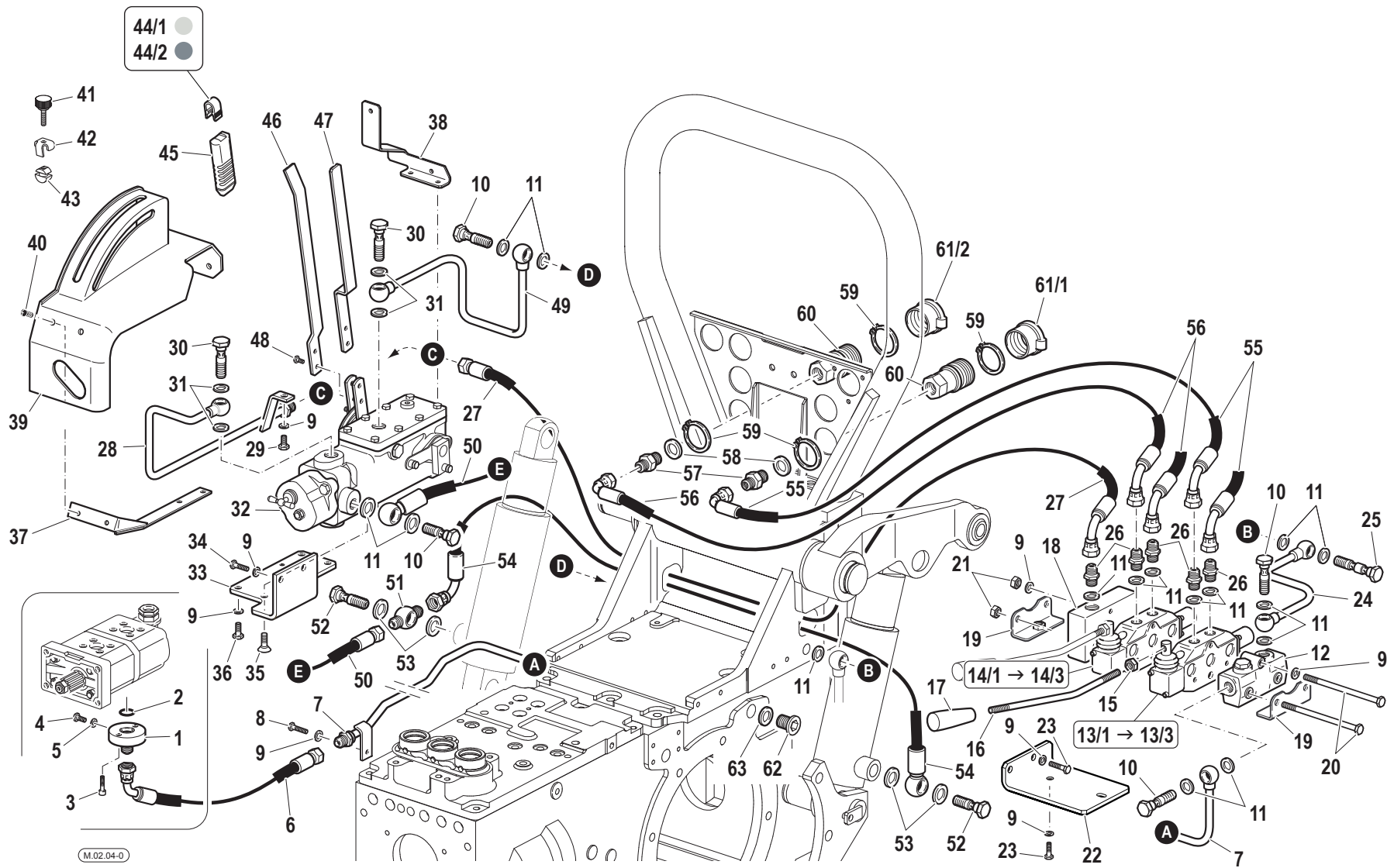

Pos.	Code	Q.ty	Description	Notes
31	F0824141000	4	COPPER WASHER 21x27/1,5	
32	58175191	1	DISTRIBUTOR	
33	56075161	1	FIXING BRACKET	
34	31112150	2	SCREW TE M8X20 UNI 5739 8G	
35	F0862481000	1	SCREW M8x16 UNI 5933	
36	31111151	3	SCREW TE M8X16 UNI 5739 8G	
37	59075254	1	FIXING BRACKET	
38	56075252	1	FIXING BRACKET	
39	57375195	1	COVER	
40	F0861973000	4	SCREW M6X10 COMBI	
41	58177761	1	KNOB	
42	56075197	1	CLIP	
43	56077760	1	SMALL BLOCK	
44/1	58175211	1	INSERT	
44/2	58175188	1	INSERT	
45	58175187	2	KNOB	
46	56075185	1	COMMAND LEVER	
47	56075186	1	COMMAND LEVER	
48	31112090	4	SCREW TE M6X16 UNI 5739 8G	
49	59075171	1	EXHAUST	
50	58075160	1	FLEXIBLE HOSE	
51	58170512	1	EYELET	
52	F0843110010	2	THREADED TERMINAL END M18x1,5	
53	F0824113000	4	COPPER WASHER 18X24/1,5	
54	58070513	1	FLEXIBLE HOSE	
55	58074958	2	FLEXIBLE HOSE	
56	58075226	1	FLEXIBLE HOSE	
57	F0835037000	3	NIPPLE	
58	F0824141000	3	COPPER WASHER 21x27/1,5	
59	F0801282000	6	SEEGER RING E 38 UNI 7435	
60	F0825980030	3	COUPLING	
61/1	F0852550020	2	GUARD	
61/2	F0852550030	1	GUARD	
62	56370081	1	PLUG	

SERIAL

**CONTROL VALVES WITHOUT FREE DISCHARGE VERSION**

CODE REV

**M.02.04\_0\_41480**

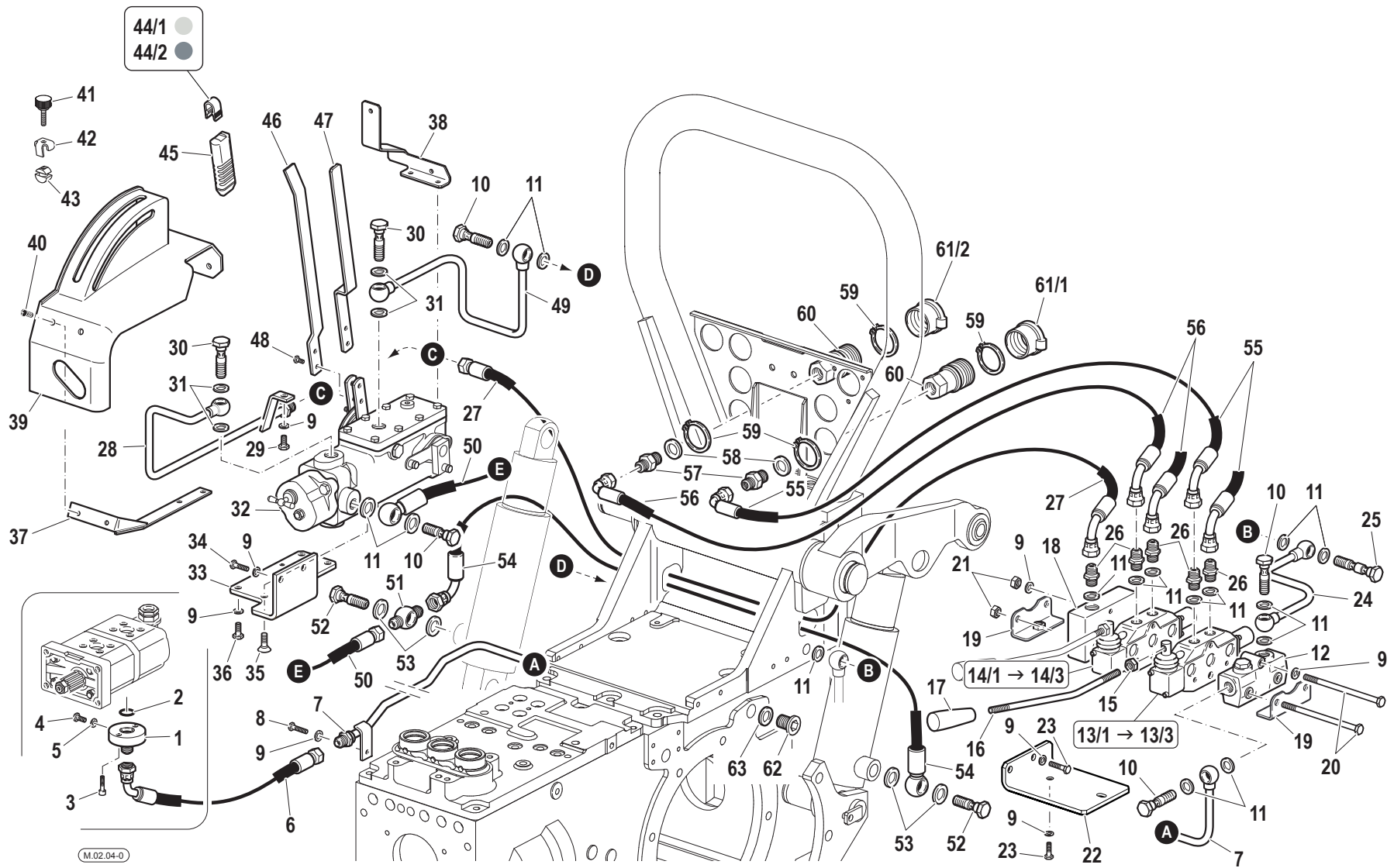

Pos.	Code	Q.ty	Description	Notes
63	F0844273090	1	GASKET 22X28X1,5 CU 99,5	

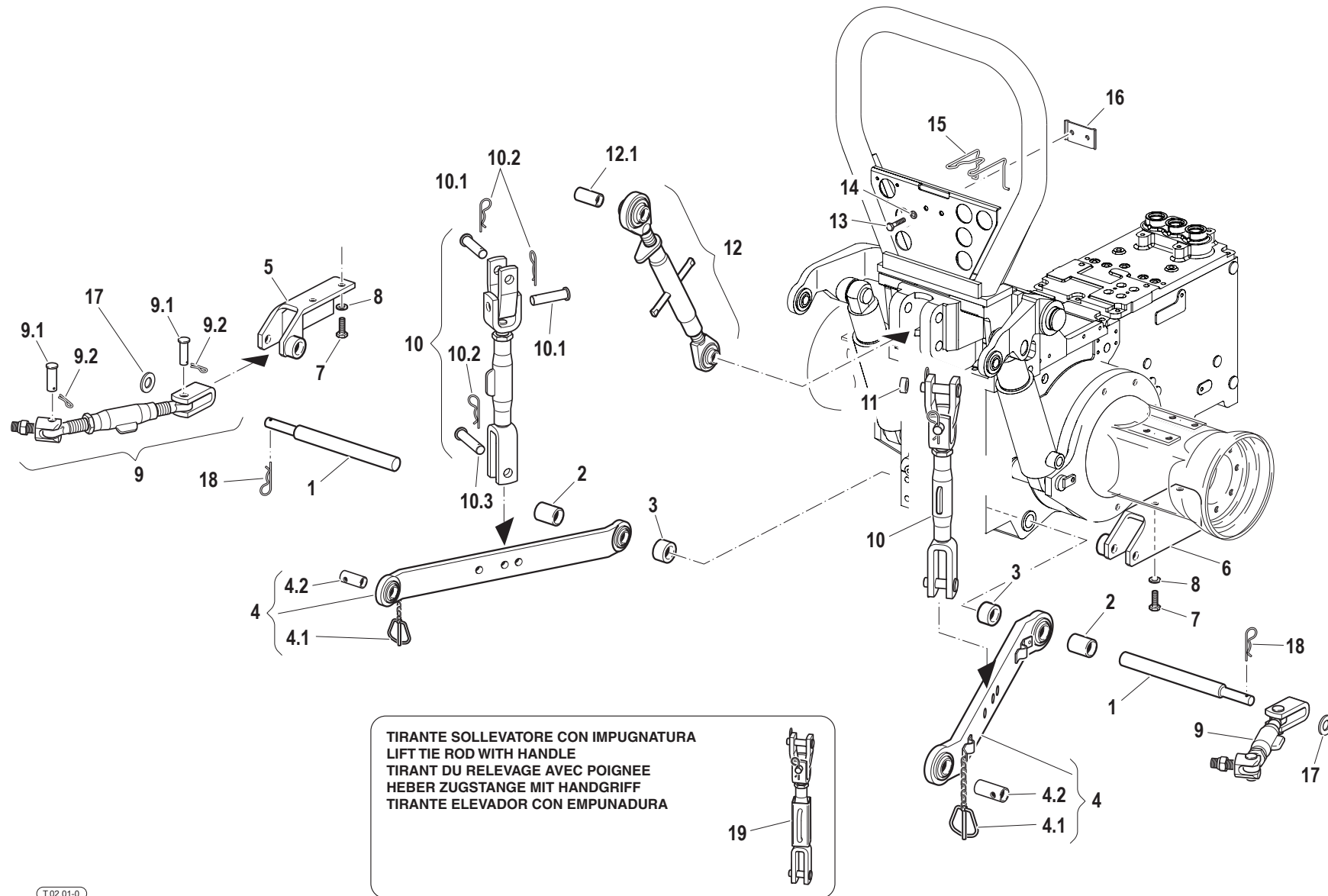

**TIRANTE SOLLEVATORE CON IMPUGNATURA**  
**LIFT TIE ROD WITH HANDLE**  
**TIRANT DU RELEVAGE AVEC POIGNEE**  
**HEBER ZUGSTANGE MIT HANDGRIFF**  
**TIRANTE ELEVADOR CON EMPUNADURA**



Pos.	Code	Q.ty	Description	Notes
1	56577772	2	PIN	
2	56077774	2	SPACER	
3	56170392	2	SPACER	
4	58071322	2	BOTTOM LINK	
4.1	F0852107050	1	PISTON PIN	
4.2	58171021	1	REDUCING BUSH	
5	59075791	1	SUPPORT	
6	59075840	1	SUPPORT	
7	31112272	4	SCREW TE M12X30 UNI 5739	
8	F0843843060	4	WASHER 12	
9	58076355	2	ROD	
9.1	58070480	2	PIN	
9.2	34110029	2	SPLIT PIN	
10	58077205	2	ROD	
10.1	58071755	2	PIN	
10.2	F0851486000	3	SPLIT PIN	
10.3	58070482	1	PIN	
11	58071757	2	WASHER	
12	58075983	1	3-POINT HITCH	
12.1	56073059	1	REDUCING BUSH	
13	31112150	2	SCREW TE M8X20 UNI 5739 8G	
14	F0843643060	2	WASHER 8	
15	58170449	1	RETAINING SPRING	
16	59070448	1	FIXING BRACKET	
17	31411170	2	WASHER 17x30	
18	34130010	2	SPLIT PIN	
19	58077202	2	ROD	

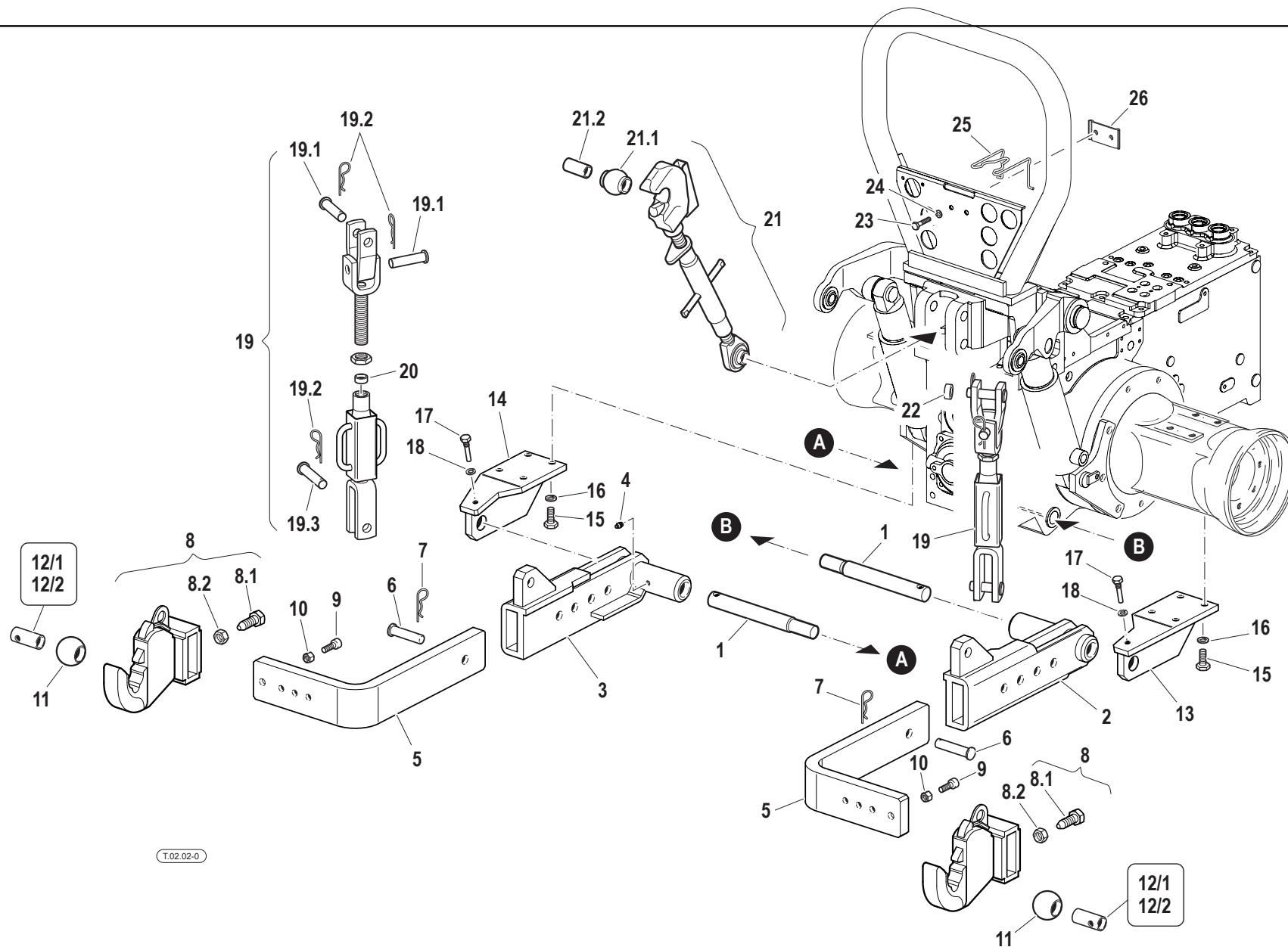

Pos.	Code	Q.ty	Description	Notes
1	56575035	2	PIN	
2	59079186	1	HOLDER	
3	59079187	1	HOLDER	
4	F0826056000	2	LUBRICATOR M10 UNI 7663A	
5	56175848	2	ARM	
6	56375954	4	PIN	
7	F0851486000	4	SPLIT PIN	
8	59076100	2	DEVICE COUPLING	
8.1	56275953	1	SCREW	
8.2	31211200	1	NUT M20	
9	F0863302000	2	SCREW M10X30 UNI 5931	
10	31211100	2	NUT M10	
11	58171000	2	JOINT	
12/1	58171021	2	REDUCING BUSH	
12/2	58177978	2	BUSHING	
13	59075850	1	SUPPORT	
14	59075885	1	SUPPORT	
15	31112272	4	SCREW TE M12X30 UNI 5739	
16	F0843843060	4	WASHER 12	
17	56075036	2	SCREW	
18	F0843755000	2	WASHER 10	
19	58077325	2	ROD	
19.1	58071755	2	PIN	
19.2	F0851486000	4	SPLIT PIN	
19.3	58070482	2	PIN	
20	56177671	2	SPACER	
21	58075987	1	3-POINT HITCH	
21.1	58173072	1	JOINT	
21.2	56073059	1	REDUCING BUSH	
22	58071757	2	WASHER	
23	31112150	2	SCREW TE M8X20 UNI 5739 8G	
24	F0843643060	2	WASHER 8	
25	58170449	1	RETAINING SPRING	
26	59070448	1	FIXING BRACKET	

SERIAL

**IMPLEMENTS ATTACHMENT - ADJUSTABLE ARMS WITH QUICK HITCHES**

CODE REV

**T.02.02\_0\_41675**

PULL HOOK - STANDARD

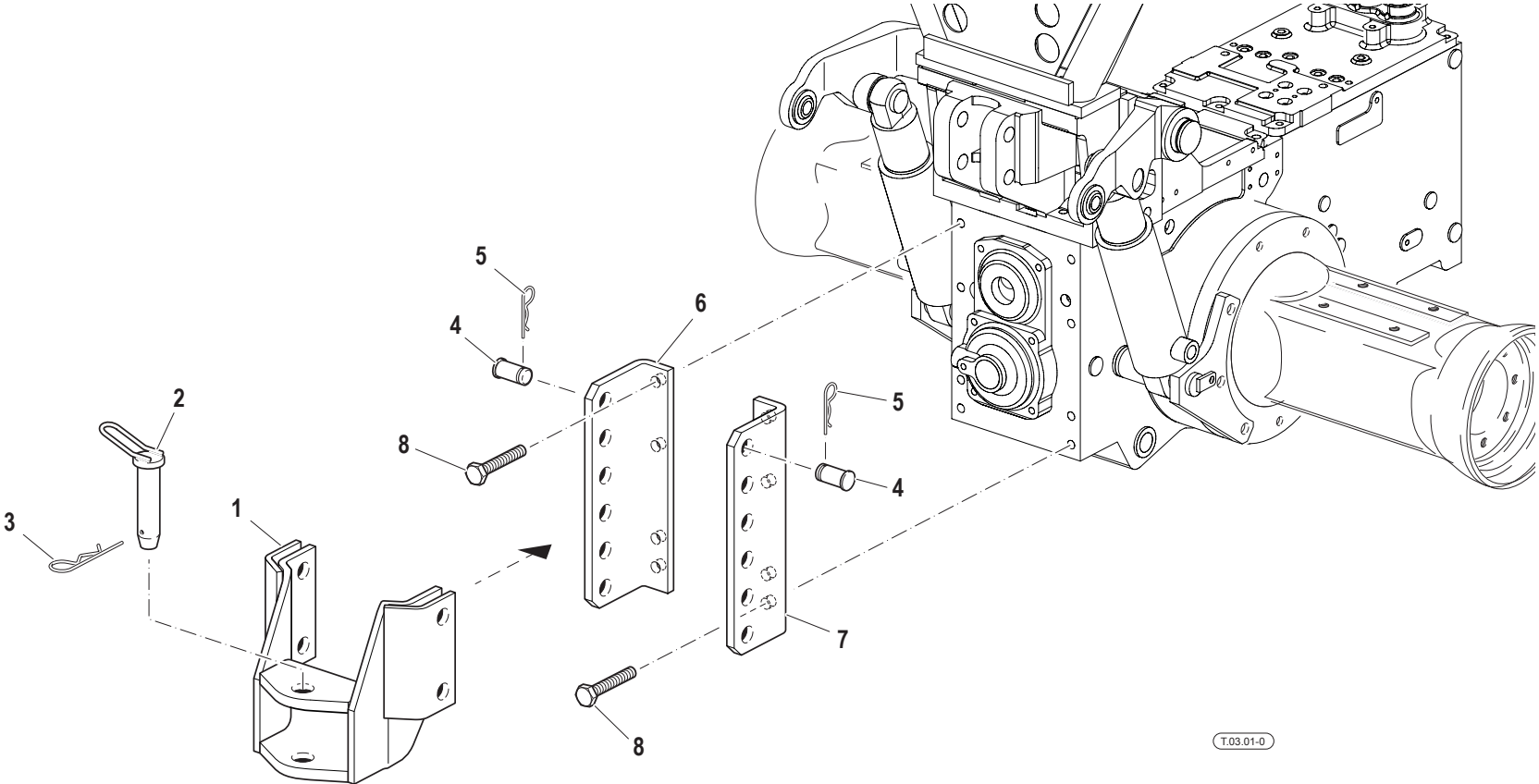

T.03.01-0

Pos.	Code	Q.ty	Description	Notes
1	59070702	1	TOW HOOK	
2	F0808060100	1	LATCH D.28X117	
3	F0851497000	1	SPLIT PIN	
4	56370696	4	PIN	
5	F0851486000	4	SPLIT PIN	
6	56170704	1	SUPPORT	
7	56170705	1	SUPPORT	
8	F0864180000	8	SCREW M14X30 UNI 5740	

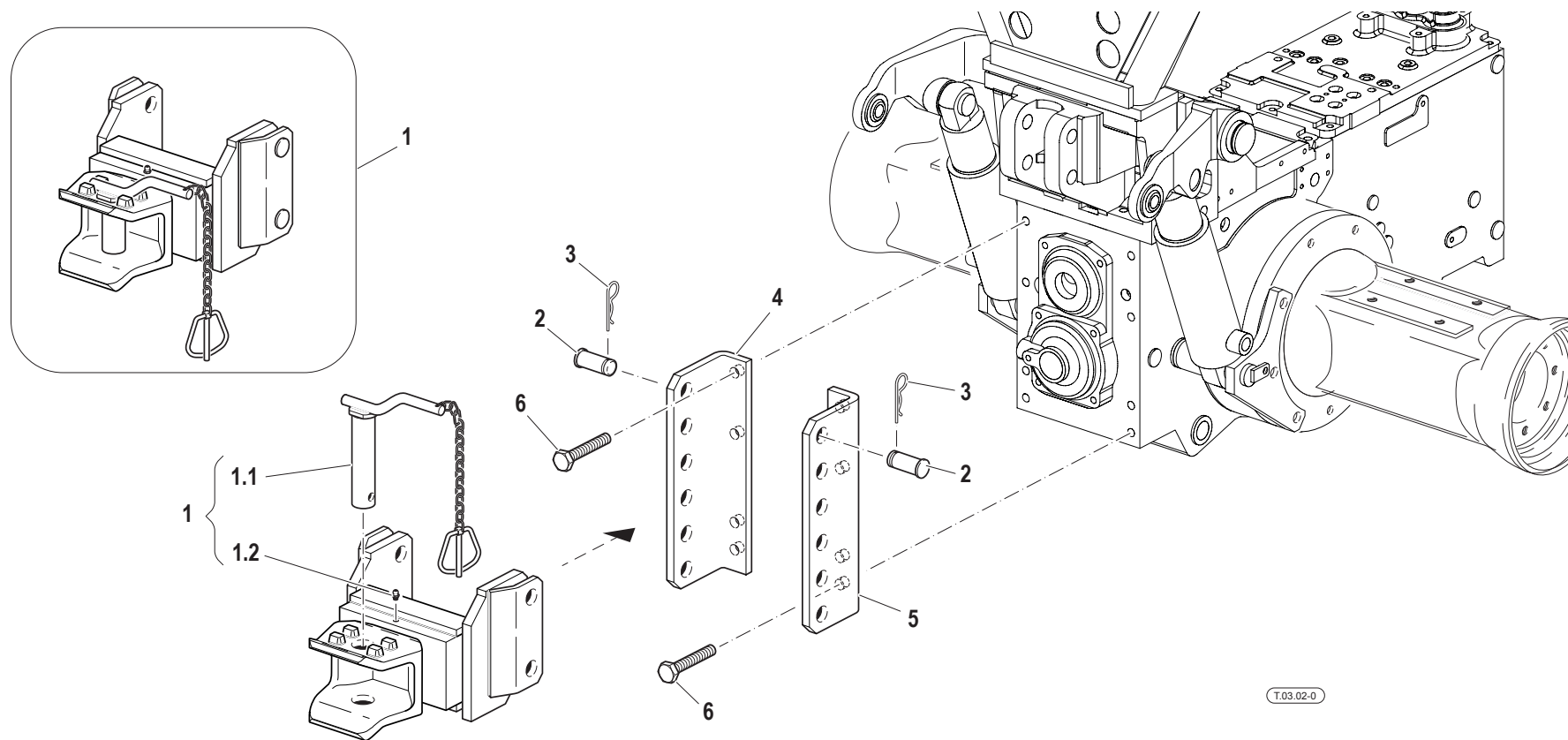

Pos.	Code	Q.ty	Description	Notes
1	59375009	1	TOW HOOK	
1.1	59075012	1	PIN	
1.2	F0826056000	1	LUBRICATOR M10 UNI 7663A	
2	56375008	4	PIN	
3	F0851486000	4	SPLIT PIN	
4	56170704	1	SUPPORT	
5	56170705	1	SUPPORT	
6	F0864180000	8	SCREW M14X30 UNI 5740	

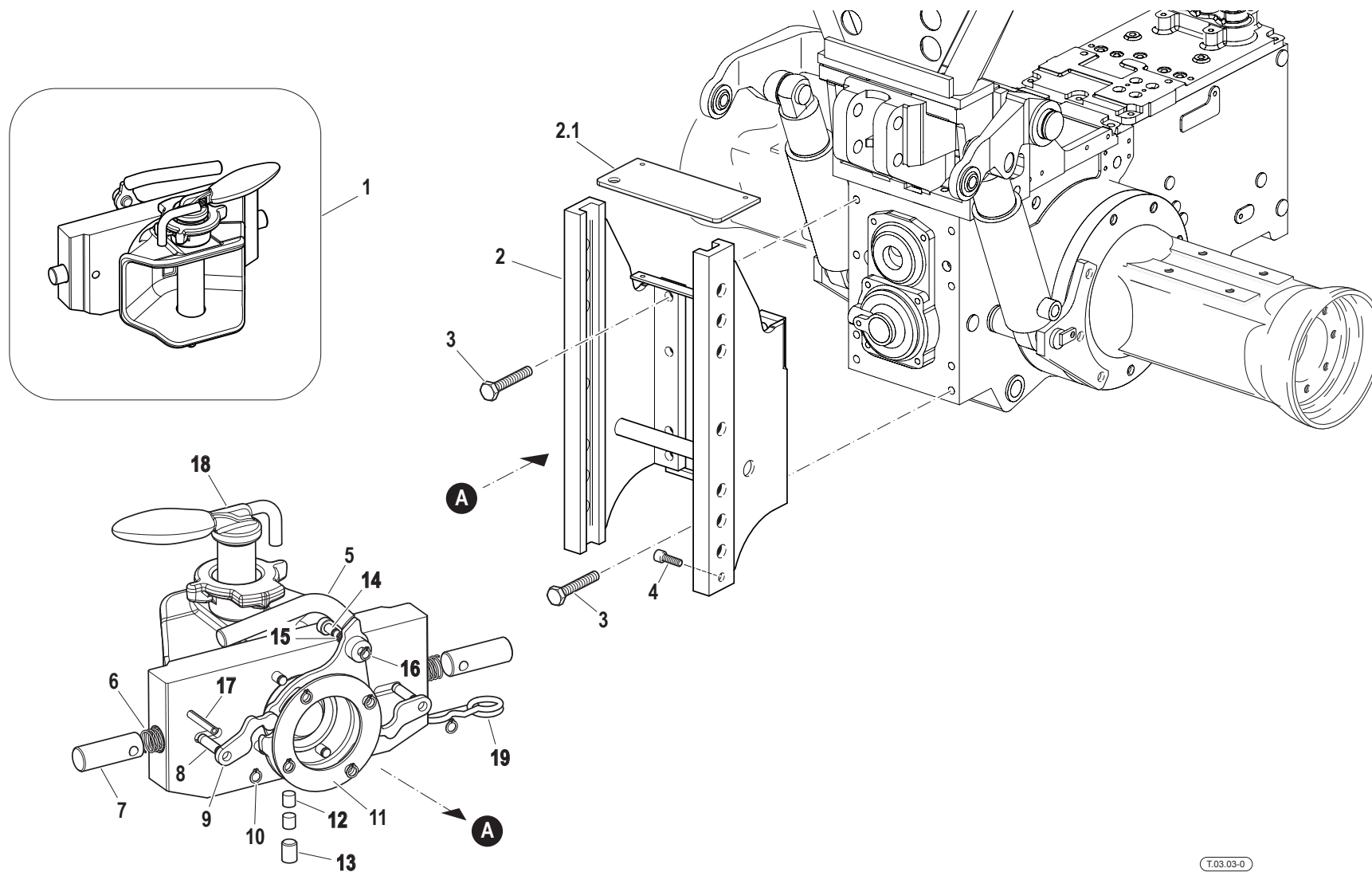



Pos.	Code	Q.ty	Description	Notes
1	59377734	1	CLEVIS	
2	59377730	1	CHASSIS FRAME	
2.1	58177732	1	GUARD	
3	F0864222010	8	SCREW M14X1,5/40 5738	
4	31152103	2	SCREW TCEI M10X25 UNI 5931	
5	58177736	1	LEVA SBLO.COMP.(81.0121.01.03)	
6	58177737	2	SPRING	
7	58177738	2	PIN	
8	58177739	6	PIN	
9	58177740	2	CONNECTING ROD	
10	F0801028000	6	RING	
11	58177741	1	DISC	
12	58177742	2	PAD	
13	F0863672010	1	SCREW	
14	58177743	1	PIN	
15	58177744	1	SPRING	
16	F0801022000	1	SEEGER RING	
17	34211064	1	ROLL PIN	
18	58177745	1	PIN	
19	58177746	1	SPLIT PIN	

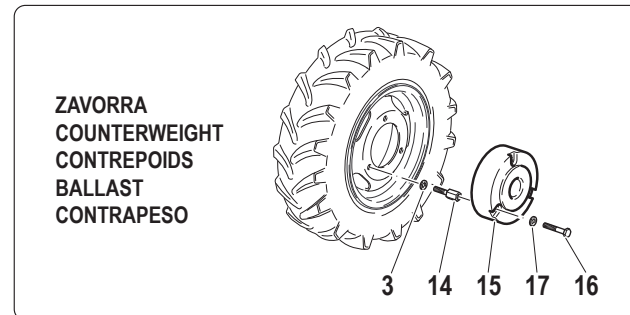
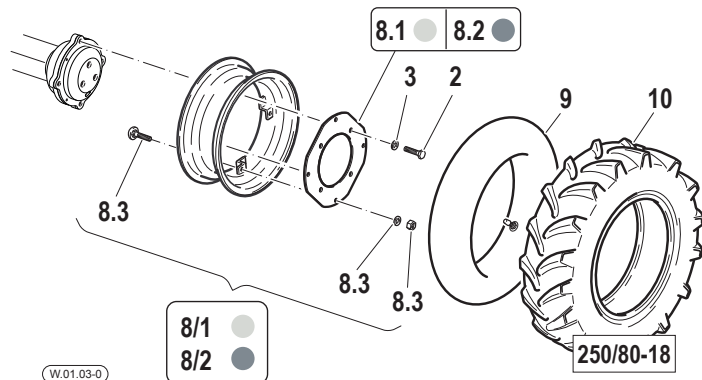
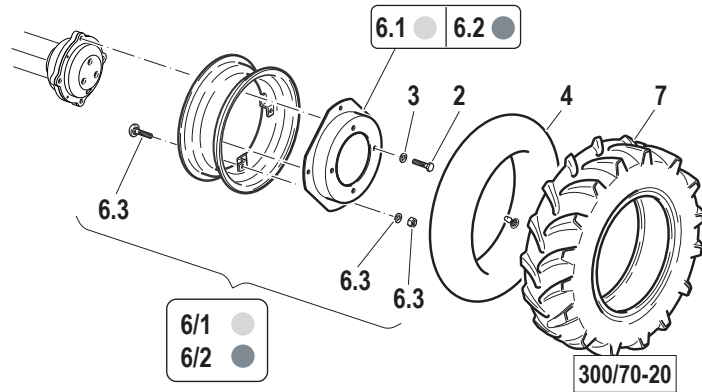
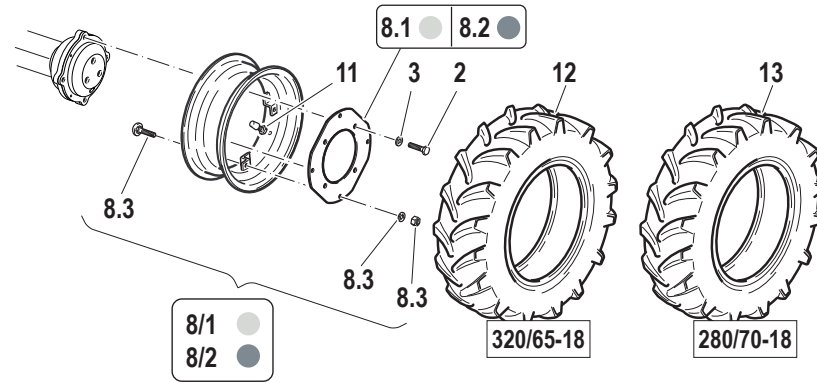
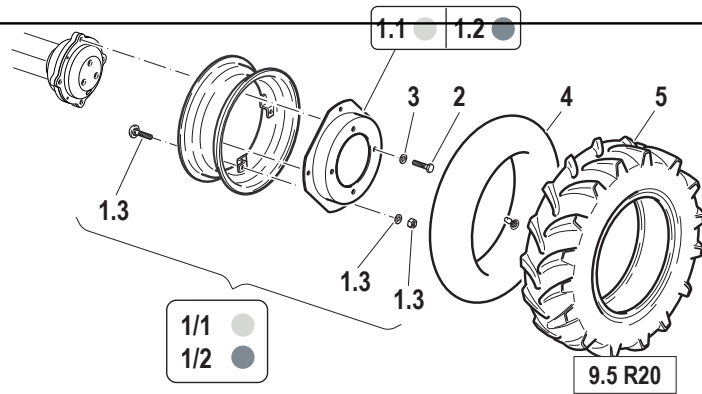

Pos.	Code	Q.ty	Description	Notes
1.1	58170181	1	DISC	
1/1	59270304	1	RIM	
1/2	59273925	1	RIM	
1.2	58175965	1	DISC	
1.3	59900361	1	KIT	
2	F0864410500	4	SCREW M18X1,5/45 U/5740	
3	F0844150000	4	WASHER D.30x18,5/5	
4	F0848920000	1	INNER TUBE	
5	F0848664000	1	TYRE 9.5-R20	
6/1	59276320	1	RIM	
6.1	58176323	1	FLANGIA CERCHIO W10X20 RAL1003	
6.2	58176324	1	FLANGIA CERCHIO W10X20 RAL9006	
6/2	59276321	1	RIM	
6.3	59900361	1	KIT	
7	F0848676050	1	TYRE 300/70 R20	
8/1	59275632	1	RIM	
8.1	58175630	1	RIM	
8.2	58175966	1	RIM	
8/2	59275633	1	RIM	
8.3	59900361	1	KIT	
9	F0848855000	1	INNER TUBE	
10	F0848655000	1	TYRE	
11	F0150010905	1	VALVE	
12	F0848679600	1	TYRE	
13	F0848655100	1	TYRE 280/70R18	
14	56370539	4	SCREW	
15	51177257	1	BALLAST	
16	F0864314000	4	SCREW	
17	F0843993060	4	WASHER	

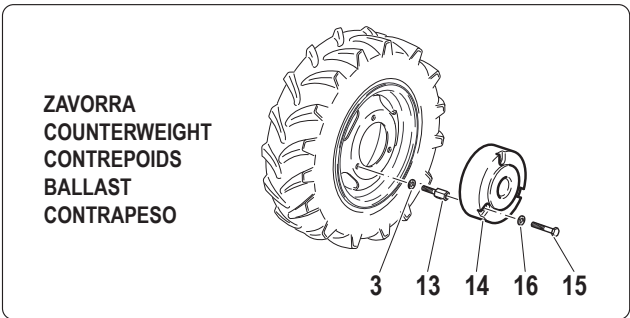
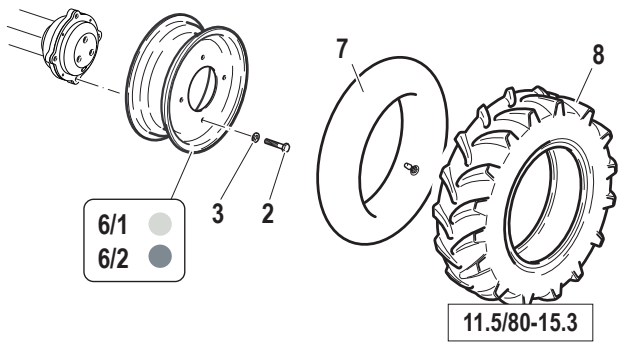
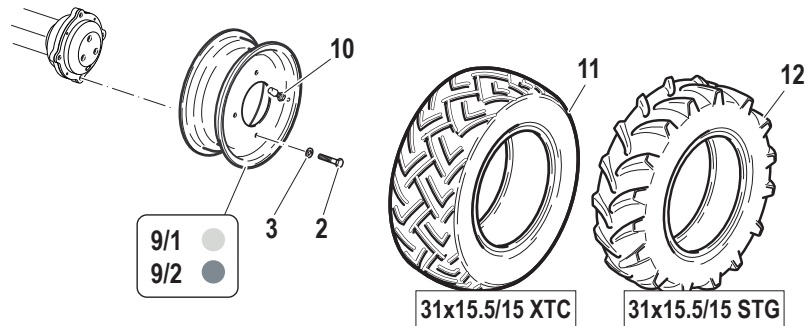
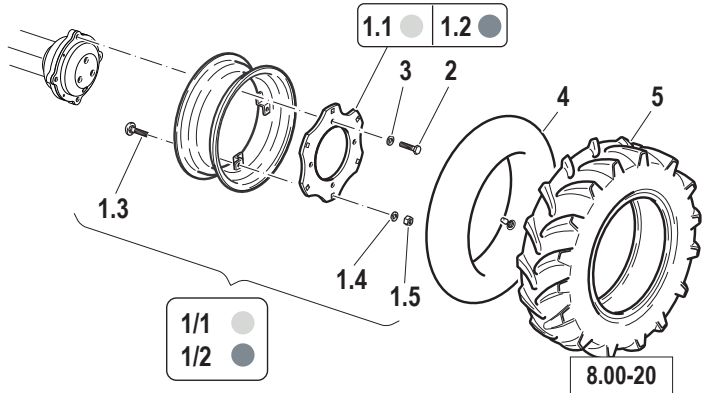

Pos.	Code	Q.ty	Description	Notes
1.1	56177416	1	DISCO CERCHIO 5,50X20 RAL 1003	
1/1	59277415	1	RIM	
1/2	59277414	1	RIM	
1.2	56177417	1	DISCO CERCHIO 5,50X20 RAL 9006	
1.3	F0864357100	5	SCREW M16x1,5x120 UNI5731	
1.4	F0844084000	5	WASHER D.35x17/4	
1.5	31221161	5	NUT M16X1,5	
2	F0864410500	4	SCREW M18X1,5/45 U/5740	
3	F0844150000	4	WASHER D.30x18,5/5	
4	F0848920000	1	INNER TUBE	
5	39118528	1	TYRE 8.00X20/8	
6/1	58176271	1	RIM	
6/2	58176272	1	RIM	
7	F0848844000	1	INNER TUBE	
8	F0848672100	1	TYRE	
9/1	58178571	1	RIM	
9/2	58178572	1	RIM	
10	F0150010905	1	VALVE	
11	F0848681600	1	TYRE 31X15.5-15 8PR	
12	F0848681605	1	TYRE 31X15.5-15	
13	56370539	4	SCREW	
14	51177257	1	BALLAST	
15	F0864314000	4	SCREW	
16	F0843993060	4	WASHER	

# SPARE PARTS INSTANCE INDEX





## SPARE PARTS INSTANCE INDEX

Code	Parts Table	Pos.	Q.ty	Code	Parts Table	Pos.	Q.ty	Code	Parts Table	Pos.	Q.ty
28174882	A.03.01_0_45689	5	1	31111151	L.02.05_0_41145	8	1	31112146	D.07.02_1_39700	11	4
	A.03.02_0_45727	5	1		M.02.03_0_41409	8	1		D.15.04_0_40488	28	4
30000005	C.02.04_1_39212	8	1		M.02.03_0_41409	36	3	31112147	B.11.01_0_38871	17	2
30000007	C.02.04_1_39212	9	1		M.02.04_0_41480	8	1		D.15.04_0_40488	26	2
	D.03.02_1_39804	21	1		M.02.04_0_41480	36	3	31112148	A.02.02_0_42523	13	2
30000197	L.02.02_0_40987	31	6	31111156	D.01.02_0_40152	2/2	1	31112149	B.08.02_0_38771	23	2
	L.02.05_0_41145	32	7	31111218	A.05.02_0_45864	14	2		L.01.01_0_40903	9	2
	M.02.03_0_41409	26	4	31111331	B.01.01_0_47067	2	4		M.01.01_0_41199	10	2
	M.02.04_0_41480	26	4	31112051	A.02.02_0_42523	22	1		M.02.03_0_41409	29	1
30000506	E.03.02_0_42668	15	1	31112082	A.01.01_1_48842	13	2		M.02.04_0_41480	29	1
30000514	B.03.03_0_50588	26	1		A.01.02_1_45599	13	2	31112150	A.01.01_1_48842	3	3
30000614	B.08.02_0_38771	8	1		A.01.03_1_45644	13	2		A.02.02_0_42523	6	1
30000638	E.03.02_0_42668	8	1		A.03.01_0_45689	2	4		B.01.01_0_47067	5	2
30000795	F.03.04_1_40827	46	1		A.03.02_0_45727	2	4		B.02.01_1_47161	8	2
30040035	C.03.02_0_39268	14	1		B.01.01_0_47067	22	12		B.04.07_0_40076	35	4
30040095	B.05.04_0_50716	16	8		C.01.02_0_39031	25	8		D.02.02_0_39318	3	6
31111090	F.04.01_0_46735	26	1		E.01.01_0_42630	3	4		D.13.01_0_40355	7	1
31111091	A.03.01_0_45689	35	4		L.01.01_0_40903	14	2		F.01.03_0_51164	25	4
	A.03.02_0_45727	35	4		M.01.01_0_41199	15	2		F.03.04_1_40827	26	2
	B.02.01_1_47161	14	2	31112090	A.01.01_1_48842	23	2		F.04.01_0_46735	2	2
	M.01.01_0_41199	62	1		A.01.02_1_45599	23	2		L.01.01_0_40903	25	2
31111151	A.01.01_1_48842	7	4		A.01.03_1_45644	23	2		L.02.02_0_40987	24	8
	A.01.02_1_45599	7	4		C.01.02_0_39031	3	4		L.02.05_0_41145	25	8
	A.01.03_1_45644	7	4		F.02.01_0_51232	6	4		M.01.01_0_41199	35	2
	A.03.01_0_45689	27	2		F.03.04_1_40827	38	1		M.02.03_0_41409	23	4
	A.03.02_0_45727	27	2		M.02.03_0_41409	48	4		M.02.03_0_41409	34	2
	A.05.02_0_45864	29	1		M.02.04_0_41480	48	4		M.02.04_0_41480	23	4
	B.01.01_0_47067	18	1	31112092	F.03.04_1_40827	7	2		M.02.04_0_41480	34	2
	B.04.07_0_40076	24	8	31112093	B.02.01_1_47161	24	8		T.02.01_0_41647	13	2
	B.11.01_0_38871	41	4		C.02.04_1_39212	30	4		T.02.02_0_41675	23	2
	B.12.04_0_51054	10	5		M.01.01_0_41199	56	2	31112151	A.03.01_0_45689	16	1
	C.02.04_1_39212	17	2	31112096	A.05.02_0_45864	27	2		A.03.02_0_45727	16	1
	F.01.03_0_51164	16	4	31112146	B.11.01_0_38871	14	2		B.01.01_0_47067	8	1
	L.02.02_0_40987	8	1		C.02.04_1_39212	22	2		C.03.02_0_39268	3	6



## SPARE PARTS INSTANCE INDEX

Code	Parts Table	Pos.	Q.ty	Code	Parts Table	Pos.	Q.ty	Code	Parts Table	Pos.	Q.ty
31112151	D.15.04_0_40488	21	1	31112219	M.01.01_0_41199	2	1	31211060	A.01.02_1_45599	25	2
31112152	D.07.02_1_39700	12	3	31112264	B.03.03_0_50588	17	8		A.01.03_1_45644	25	2
31112153	A.01.01_1_48842	17	1		B.03.04_0_50621	17	8		A.03.01_0_45689	36	2
	A.01.02_1_45599	17	1	31112272	T.02.01_0_41647	7	4		A.03.02_0_45727	36	2
	A.01.03_1_45644	17	1		T.02.02_0_41675	15	4		B.02.01_1_47161	16	2
31112161	D.11.01_0_40184	3	2	31112328	B.01.01_0_47067	25	2		B.04.07_0_40076	21	4
31112174	A.01.01_1_48842	15	1	31112801	B.05.03_0_50689	19	4		F.02.01_0_51232	8	4
	A.01.02_1_45599	15	1	31122804	B.04.07_0_40076	10	4	31211080	A.01.01_1_48842	9	2
	A.01.03_1_45644	15	1	31132440	B.11.01_0_38871	24	4		A.01.02_1_45599	9	2
31112178	B.04.07_0_40076	37	2	31132562	A.02.02_0_42523	2	2		A.01.03_1_45644	9	2
31112210	A.01.01_1_48842	31	1		C.02.04_1_39212	29	4		A.03.01_0_45689	18	1
	A.01.02_1_45599	31	1	31132566	D.13.01_0_40355	6	1		A.03.02_0_45727	18	1
	A.01.03_1_45644	31	1	31152057	L.02.02_0_40987	3	2		A.04.01_0_45765	4	3
	B.04.07_0_40076	36	1		L.02.05_0_41145	3	2		A.04.02_0_45780	4	3
	E.02.01_0_46767	5	1		M.02.03_0_41409	3	2		A.04.03_0_45796	4	3
	F.01.03_0_51164	18	4		M.02.04_0_41480	3	2		A.04.04_0_45812	4	3
	F.02.01_0_51232	9	2	31152060	A.02.02_0_42523	17	1		A.05.02_0_45864	10	6
	F.03.04_1_40827	2	1	31152066	B.11.01_0_38871	12	4		B.02.01_1_47161	10	6
31112211	B.04.07_0_40076	8	3	31152068	A.02.02_0_42523	18	1		B.04.07_0_40076	15	8
	C.01.02_0_39031	6	2	31152083	F.01.03_0_51164	2	4		B.11.01_0_38871	40	2
	F.03.04_1_40827	6	2		F.02.01_0_51232	2	4		D.02.02_0_39318	11	1
	L.01.01_0_40903	3	5	31152085	D.11.01_0_40184	2	2		D.12.01_1_40279	61	6
	M.01.01_0_41199	3	4	31152088	B.02.01_1_47161	11	2		L.02.02_0_40987	21	12
31112212	A.03.01_0_45689	11	2	31152097	M.01.01_0_41199	47	2		L.02.05_0_41145	22	6
	A.03.02_0_45727	11	2	31152103	A.03.01_0_45689	14	1		M.02.03_0_41409	21	3
	C.01.02_0_39031	7	7		A.03.02_0_45727	14	1		M.02.04_0_41480	21	3
31112213	C.01.02_0_39031	8	1		T.03.03_0_42459	4	2	31211100	L.02.02_0_40987	16	4
31112217	M.01.01_0_41199	5	1	31200501	A.04.01_0_45765	3	1		L.02.05_0_41145	17	4
31112219	A.01.01_1_48842	10	5		A.04.02_0_45780	3	1		M.02.03_0_41409	15	2
	A.01.02_1_45599	10	5		A.04.03_0_45796	3	1		M.02.04_0_41480	15	2
	A.01.03_1_45644	10	5		A.04.04_0_45812	3	1		T.02.02_0_41675	10	2
	B.04.07_0_40076	7	3	31211050	A.02.02_0_42523	25	1	31211200	T.02.02_0_41675	8.2	1
	F.03.04_1_40827	3	3		E.03.02_0_42668	7	3	31221161	W.01.04_0_45316	1.5	5
	L.01.01_0_40903	2	1	31211060	A.01.01_1_48842	25	2	31231080	A.02.02_0_42523	20	3





## SPARE PARTS INSTANCE INDEX

Code	Parts Table	Pos.	Q.ty	Code	Parts Table	Pos.	Q.ty	Code	Parts Table	Pos.	Q.ty
31231080	B.01.01_0_47067	15	1	31411150	B.01.01_0_47067	27	2	37112302	D.02.02_0_39318	8	1
31231120	D.14.01_0_40378	11	4		D.15.04_0_40488	23	2	37112501	D.04.01_1_42845	13	1
31241080	B.01.01_0_47067	11	1	31411170	T.02.01_0_41647	17	2	37221320	D.06.01_1_42932	26	2
31241121	M.01.01_0_41199	50	2	31421083	A.01.01_1_48842	18	1	37931413	D.12.01_1_40279	20	1
31312089	D.12.01_1_40279	60	4		A.01.02_1_45599	18	1	38104412	D.02.02_0_39318	25	1
31313300	C.03.02_0_39268	7	10		A.01.03_1_45644	18	1	38110992	D.03.02_1_39804	13	1
31313320	C.03.02_0_39268	8	6		D.02.02_0_39318	4	6	38111078	D.13.01_0_40355	17	2
31411053	A.02.02_0_42523	23	1	31421251	A.01.01_1_48842	20	1	38112200	D.13.01_0_40355	3	1
31411064	A.01.01_1_48842	14	2		A.01.02_1_45599	20	1		F.01.03_0_51164	6	2
	A.01.02_1_45599	14	2		A.01.03_1_45644	20	1	38113142	F.01.03_0_51164	28	2
	A.01.03_1_45644	14	2	31510053	B.08.02_0_38771	6	6	38116317	D.12.01_1_40279	54	1
	A.03.01_0_45689	4	4	34110029	T.02.01_0_41647	9.2	2	38118720	D.12.01_1_40279	55	1
	A.03.02_0_45727	4	4	34110030	M.01.01_0_41199	59	1	39118528	W.01.04_0_45316	5	1
	E.01.01_0_42630	4	4	34130010	T.02.01_0_41647	18	2	41U50000	A.01.01_1_48842	1	1
	F.03.04_1_40827	40	1	34211054	D.13.01_0_40355	4	1	41U60000	A.01.02_1_45599	1	1
31411066	A.03.01_0_45689	37	6	34211064	T.03.03_0_42459	17	1	41U70000	A.01.03_1_45644	1	1
	A.03.02_0_45727	37	6	34213018	B.11.01_0_38871	47	1	50970418	D.15.04_0_40488	33	1
	B.02.01_1_47161	25	16	34213054	D.11.01_0_40184	8	1	50973415	M.01.01_0_41199	40	2
	B.04.07_0_40076	32	4	34321066	D.15.04_0_40488	7	2	51170020	C.03.02_0_39268	6	2
31411084	B.01.01_0_47067	6	3	35111047	D.12.01_1_40279	4	1	51172005	D.10.01_0_39887	3	1
	B.02.01_1_47161	4	6	35111052	D.05.01_1_42883	10	1	51173371	M.01.01_0_41199	49	1
	B.04.07_0_40076	25	4	35111062	D.02.02_0_39318	7	2	51173650	C.03.02_0_39268	2	1
	B.08.02_0_38771	17	4		D.09.02_0_39867	2	2	51173805	C.01.02_0_39031	16	1
	B.08.02_0_38771	24	2	35111080	D.02.02_0_39318	15	4	51173806	C.01.02_0_39031	15	1
	B.11.01_0_38871	7	4		D.06.01_1_42932	27	1	51174047	M.01.01_0_41199	1	1
	D.03.02_1_39804	27	1	35121030	D.02.02_0_39318	6	2	51174315	L.01.01_0_40903	1	1
	F.03.04_1_40827	28	2	35121035	D.06.01_1_42932	17	1	51174524V	B.11.01_0_38871	26	1
31411090	B.01.01_0_47067	10	1	35121040	D.04.01_1_42845	11	1	51176033	C.03.02_0_39268	10	1
	B.04.07_0_40076	14	4		D.12.01_1_40279	8	1	51176034	C.03.02_0_39268	11	1
31411104	M.01.01_0_41199	22	3	35211060	B.02.01_1_47161	19	1	51176123	C.03.02_0_39268	1	1
31411105	D.03.02_1_39804	23	2	35211070	M.01.01_0_41199	27	2	51176125	C.01.02_0_39031	2	1
	D.15.04_0_40488	20	2	37111254	D.09.02_0_39867	3	1	51176126	C.01.02_0_39031	1	1
31411130	D.14.01_0_40378	9	2	37111255	D.05.01_1_42883	9	1	51176714	B.01.01_0_47067	1	1
	D.15.04_0_40488	13	2	37111354	D.02.02_0_39318	16	1	51177257	W.01.03_0_44163	15	1



## SPARE PARTS INSTANCE INDEX

Code	Parts Table	Pos.	Q.ty	Code	Parts Table	Pos.	Q.ty	Code	Parts Table	Pos.	Q.ty
51177257	W.01.04_0_45316	14	1	52379209	C.02.04_1_39212	5	2	52476868	D.12.01_1_40279	3	1
51179545	D.07.02_1_39700	9	1	52470061	D.01.02_0_40152	17	1	52478565	D.12.01_1_40279	28	1
51270203	D.11.01_0_40184	15	1		D.09.02_0_39867	7	1	52478568	D.12.01_1_40279	19	1
51270771	D.07.02_1_39700	32	1	52470062	D.01.02_0_40152	16	1	52478609	D.06.01_1_42932	7	1
51274388	B.11.01_0_38871	27	1		D.09.02_0_39867	6	1	52478611	D.06.01_1_42932	3	1
51274498	B.11.01_0_38871	28	1	52470067	D.01.02_0_40152	20	2	52478612	D.05.01_1_42883	3	1
51275570	D.13.01_0_40355	13	1		D.09.02_0_39867	8	2	52478615	D.06.01_1_42932	22	1
51278573	D.11.01_0_40184	10	1	52470087	D.10.01_0_39887	11	3	52478617	D.06.01_1_42932	25	1
51278623	D.07.02_1_39700	31	1	52470117	D.06.01_1_42932	19	1	52478618	D.04.01_1_42845	17	1
51371035	D.01.02_0_40152	21	1	52470118	D.06.01_1_42932	18	1	52478619	D.04.01_1_42845	18	1
	D.09.02_0_39867	11	1	52470298	D.12.01_1_40279	7	1	52478620	D.04.01_1_42845	20	1
52071702	L.01.01_0_40903	13	1	52473655	D.02.02_0_39318	35	1	52573648	D.02.02_0_39318	21	1
	M.01.01_0_41199	14	1	52473656	D.04.01_1_42845	24	1	53273025	D.02.02_0_39318	26	1
52173669	C.02.04_1_39212	10	1	52473660	D.02.02_0_39318	12	1	53273886	D.12.01_1_40279	33	1
52173670	C.02.04_1_39212	10	1	52473827	D.05.01_1_42883	8	1	53273891	D.12.01_1_40279	56	1
52173671	C.02.04_1_39212	10	1	52473829	D.05.01_1_42883	5	1	55072935	B.05.03_0_50689	1	4
52173672	C.02.04_1_39212	10	1	52473830	D.05.01_1_42883	6	1	55170047	D.14.01_0_40378	7	2
52173673	C.02.04_1_39212	10	1	52473831	D.05.01_1_42883	7	1	55170053	D.07.02_1_39700	6	3
52272112	D.07.02_1_39700	28	1	52473835	D.06.01_1_42932	9	1	55174162	B.11.01_0_38871	33	1
52273364	D.07.02_1_39700	29	1	52473836	D.06.01_1_42932	12	1	55174163	B.11.01_0_38871	32	2
52274299	D.07.02_1_39700	26	1	52473837	D.06.01_1_42932	13	1	55174429	C.02.04_1_39212	27	2
52370072	D.10.01_0_39887	6	1	52473838	D.04.01_1_42845	5	1	55174632	A.03.01_0_45689	21	1
52370075	D.10.01_0_39887	5	1	52473839	D.04.01_1_42845	9	1		A.03.02_0_45727	21	1
52370152	D.13.01_0_40355	2	1	52474251	D.06.01_1_42932	15	1	55175174	B.04.07_0_40076	13	6
52372292	D.12.01_1_40279	38	1	52475562	D.12.01_1_40279	32	1		B.05.03_0_50689	22	8
52373177	D.15.04_0_40488	10	2	52475565	D.12.01_1_40279	43	1		B.05.04_0_50716	18	8
52374189	D.07.02_1_39700	2	1	52475991	D.12.01_1_40279	24	1	55176744	A.01.01_1_48842	26	1
52374386	D.07.02_1_39700	3	1	52475992	D.12.01_1_40279	46	1		A.01.02_1_45599	26	1
52374641	D.11.01_0_40184	1	1	52475994	D.12.01_1_40279	44/1	1		A.01.03_1_45644	26	1
52375215	D.15.04_0_40488	14	1	52475996	D.12.01_1_40279	44/2	1	55177639	A.03.01_0_45689	23	1
52375896	D.07.02_1_39700	27	1	52476062	D.12.01_1_40279	17	1		A.03.02_0_45727	23	1
52378628	D.07.02_1_39700	36	1	52476065	D.12.01_1_40279	22/1	1	55271644	B.08.02_0_38771	5	1
52378629	D.07.02_1_39700	30	1	52476066	D.12.01_1_40279	22/2	1	55274441	B.08.02_0_38771	4	1
52378636	D.07.02_1_39700	4	1	52476068	D.12.01_1_40279	16	1	55276745	A.05.02_0_45864	1	1



## SPARE PARTS INSTANCE INDEX

Code	Parts Table	Pos.	Q.ty	Code	Parts Table	Pos.	Q.ty	Code	Parts Table	Pos.	Q.ty
56071768	A.02.02_0_42523	12	4	56170017	D.07.02_1_39700	16	1	56171954	B.04.07_0_40076	16	2
56073059	T.02.01_0_41647	12.1	1	56170029	D.03.02_1_39804	14	1		B.05.03_0_50689	23	8
	T.02.02_0_41675	21.2	1	56170043	D.14.01_0_40378	8	2		B.05.04_0_50716	19	8
56073413	M.01.01_0_41199	44	2	56170074	D.10.01_0_39887	9	1	56171996	B.04.07_0_40076	12	4
56073414	M.01.01_0_41199	41	2	56170213	D.01.02_0_40152	8	1	56172172	B.12.03_0_46827	7/2	1
56073416	M.01.01_0_41199	45	1	56170214	D.01.02_0_40152	6	1	56172538	C.01.02_0_39031	24	1
56074302	D.03.02_1_39804	25	1	56170276	A.05.02_0_45864	16	2	56172547	F.02.01_0_51232	13	1
56074313	D.12.01_1_40279	65	1	56170283	L.01.01_0_40903	27	2	56172749	F.04.01_0_46735	4	1
56075036	T.02.02_0_41675	17	2		M.01.01_0_41199	37	2	56173638	L.01.01_0_40903	8	1
56075143	M.01.01_0_41199	58	1	56170285	L.01.01_0_40903	29	2		M.01.01_0_41199	9	1
56075145	M.01.01_0_41199	26	1		M.01.01_0_41199	39	2	56173684	D.03.02_1_39804	20	1
56075161	M.02.03_0_41409	33	1	56170286	L.01.01_0_40903	28	2	56174108	D.12.01_1_40279	5	1
	M.02.04_0_41480	33	1		M.01.01_0_41199	38	2	56174201	L.02.02_0_40987	23	1
56075185	M.02.03_0_41409	46	1	56170350	F.01.03_0_51164	13	1		L.02.05_0_41145	24	1
	M.02.04_0_41480	46	1	56170364	C.02.04_1_39212	21	2		M.02.03_0_41409	22	1
56075186	M.02.03_0_41409	47	1	56170367	D.15.04_0_40488	3	2		M.02.04_0_41480	22	1
	M.02.04_0_41480	47	1	56170392	T.02.01_0_41647	3	2	56174227	L.02.02_0_40987	22	1
56075197	M.02.03_0_41409	42	1	56170447	D.13.01_0_40355	11	1		L.02.05_0_41145	23	1
	M.02.04_0_41480	42	1	56170704	T.03.01_0_41710	6	1	56174400	D.03.02_1_39804	38	1
56075230	D.03.02_1_39804	33	1		T.03.02_0_41719	4	1	56174401	D.03.02_1_39804	39	1
56075252	M.02.03_0_41409	38	1	56170705	T.03.01_0_41710	7	1	56174431	D.13.01_0_40355	10	1
	M.02.04_0_41480	38	1		T.03.02_0_41719	5	1	56174446	C.02.04_1_39212	28	4
56076055	D.13.01_0_40355	20	1	56170760	D.06.01_1_42932	24	1	56174461	B.11.01_0_38871	42	1
56076928	B.02.01_1_47161	1.3	1	56170795	D.15.04_0_40488	8	1	56174462	B.11.01_0_38871	37	1
56076929	B.02.01_1_47161	1.4	1	56170796	D.15.04_0_40488	9	1	56174463	B.11.01_0_38871	45	1
56076930	B.02.01_1_47161	1.5	1	56170964	L.02.02_0_40987	17	4	56174464	B.11.01_0_38871	10	1
56076933	B.02.01_1_47161	1.2	1		L.02.05_0_41145	18	4	56174480	F.03.04_1_40827	10	1
56077235	D.15.04_0_40488	36	1		M.02.03_0_41409	16	2	56174481	F.03.04_1_40827	9	1
56077608	A.05.02_0_45864	6	2		M.02.04_0_41480	16	2	56174485	F.03.04_1_40827	30	1
56077760	M.02.03_0_41409	43	1	56171223	B.12.04_0_51054	13	1	56174486	B.11.01_0_38871	13	1
	M.02.04_0_41480	43	1	56171572	D.12.01_1_40279	1	1	56174489	B.11.01_0_38871	16	1
56077774	T.02.01_0_41647	2	2	56171877	A.02.02_0_42523	3	1	56174492	B.11.01_0_38871	2	2
56078831	B.04.07_0_40076	33	1	56171883	A.02.02_0_42523	4	1	56174494	F.03.04_1_40827	43	1
56079442	B.02.01_1_47161	1.1	1	56171936	D.15.04_0_40488	18	1	56174499	B.11.01_0_38871	20	1



## SPARE PARTS INSTANCE INDEX

Code	Parts Table	Pos.	Q.ty	Code	Parts Table	Pos.	Q.ty	Code	Parts Table	Pos.	Q.ty
56174635	A.04.01_0_45765	5	1	56176696	A.05.02_0_45864	8	2	56177475	B.05.03_0_50689	21	2
	A.04.02_0_45780	5	1	56176716	A.05.02_0_45864	7	1	56177643	B.01.01_0_47067	17	1
	A.04.03_0_45796	5	1	56176814	A.05.02_0_45864	9	3	56177655	A.02.02_0_42523	21	1
	A.04.04_0_45812	5	1	56176905	B.03.03_0_50588	14	1	56177656	A.02.02_0_42523	19	3
	A.05.02_0_45864	5	1		B.03.04_0_50621	14	1		B.01.01_0_47067	14	1
56174636	A.04.01_0_45765	2	1	56176906	B.03.03_0_50588	13	1	56177671	T.02.02_0_41675	20	2
	A.04.02_0_45780	2	1		B.03.04_0_50621	13	1	56177979	A.01.01_1_48842	8	1
	A.04.03_0_45796	2	1	56176907	B.05.03_0_50689	13	1		A.01.02_1_45599	8	1
	A.04.04_0_45812	2	1		B.05.04_0_50716	11	1		A.01.03_1_45644	8	1
56174656	B.02.01_1_47161	12	1	56176908	B.05.03_0_50689	12	1	56178560	B.04.07_0_40076	38	2
56174657	B.01.01_0_47067	4	1		B.05.04_0_50716	10	1	56178591	B.12.04_0_51054	15	1
56174658	B.01.01_0_47067	7	1	56177045	B.03.03_0_50588	32	8	56178649	A.01.02_1_45599	35	1
56174659	B.01.01_0_47067	9	1		B.03.04_0_50621	18	8		A.01.03_1_45644	35	1
56174661	A.02.02_0_42523	16	1		B.05.03_0_50689	26	8	56178695	F.04.01_0_46735	29	1
56174665	F.04.01_0_46735	1	1		B.05.04_0_50716	21	8	56178805	A.03.01_0_45689	7	1
56174666	B.04.07_0_40076	23	1	56177068	C.01.02_0_39031	20	1		A.03.02_0_45727	7	1
56174667	B.04.07_0_40076	22	1	56177183	A.01.01_1_48842	34	1	56178806	A.03.01_0_45689	12	2
56174692	D.06.01_1_42932	24	1		A.01.02_1_45599	34	1		A.03.02_0_45727	12	2
56174693	D.06.01_1_42932	24	1		A.01.03_1_45644	34	1	56179443	B.02.01_1_47161	22	1
56174694	D.06.01_1_42932	24	1	56177252	B.05.03_0_50689	2	2	56179444	B.02.01_1_47161	23	1
56174695	D.06.01_1_42932	24	1	56177256	B.03.03_0_50588	3	2	56179445	B.03.03_0_50588	12	1
56174725	F.01.03_0_51164	15	2		B.03.04_0_50621	3	2		B.03.04_0_50621	12	1
56174773	B.11.01_0_38871	11	1	56177264	B.05.03_0_50689	15	1	56179447	B.02.01_1_47161	21	2
56174835	B.02.01_1_47161	18	1		B.05.04_0_50716	13	1	56179549	B.02.01_1_47161	7	1
56174873	B.01.01_0_47067	24	1	56177265	B.05.03_0_50689	16	1	56274487	B.11.01_0_38871	35	2
56174919	C.01.02_0_39031	23	1		B.05.04_0_50716	14	1	56275953	T.02.02_0_41675	8.1	1
56174987	F.02.01_0_51232	4	1	56177326	B.03.03_0_50588	10	2	56276371	C.02.04_1_39212	24.2	1
56174988	F.02.01_0_51232	5	1		B.03.04_0_50621	10	2	56276372	C.02.04_1_39212	24.1	1
56175294	F.02.01_0_51232	17	1	56177416	W.01.04_0_45316	1.1	1	56278614	D.06.01_1_42932	6	1
56175367	D.06.01_1_42932	24	1	56177417	W.01.04_0_45316	1.2	1	56370018	D.07.02_1_39700	10	6
56175848	T.02.02_0_41675	5	2	56177443	B.05.03_0_50689	5	1	56370037	D.02.02_0_39318	33	1
56176127	D.11.01_0_40184	7	1		B.05.04_0_50716	3	1	56370038	D.14.01_0_40378	4	2
56176691	A.03.01_0_45689	15	1	56177444	B.05.03_0_50689	6	1	56370076	D.10.01_0_39887	10	6
	A.03.02_0_45727	15	1		B.05.04_0_50716	4	1	56370079	D.10.01_0_39887	7	1

## SPARE PARTS INSTANCE INDEX

Code	Parts Table	Pos.	Q.ty	Code	Parts Table	Pos.	Q.ty	Code	Parts Table	Pos.	Q.ty
56370081	C.01.02_0_39031	4	2	56370582	D.11.01_0_40184	14	1	56378622	D.07.02_1_39700	24	1
	D.10.01_0_39887	15	1	56370583	D.11.01_0_40184	13	1	56378630	D.07.02_1_39700	25	1
	L.02.05_0_41145	48	1	56370696	T.03.01_0_41710	4	4	56470002	D.02.02_0_39318	19	1
	M.02.04_0_41480	62	1	56370830	D.06.01_1_42932	28	1	56470110	D.04.01_1_42845	3	1
56370089	D.01.02_0_40152	15	1		D.09.02_0_39867	14	1	56470111	D.04.01_1_42845	14	1
	D.06.01_1_42932	28	1	56371037	D.01.02_0_40152	19	1	56470137	D.06.01_1_42932	11	1
	D.09.02_0_39867	14	1		D.09.02_0_39867	9	1	56470138	D.06.01_1_42932	10	3
56370127	D.01.02_0_40152	15	1	56371065	D.07.02_1_39700	21	1	56470139	D.04.01_1_42845	10	1
	D.06.01_1_42932	28	1	56371162	D.02.02_0_39318	18	1	56470215	D.01.02_0_40152	4	1
	D.09.02_0_39867	14	1	56371721	D.15.04_0_40488	15	1	56470231	D.14.01_0_40378	5	2
56370128	D.01.02_0_40152	15	1	56372282	D.12.01_1_40279	41	1	56470299	D.13.01_0_40355	1	1
	D.06.01_1_42932	28	1	56372536	D.01.02_0_40152	3	1	56470365	D.15.04_0_40488	19	2
	D.09.02_0_39867	14	1	56373194	D.03.02_1_39804	30	2	56470797	D.15.04_0_40488	11	2
56370165	D.07.02_1_39700	23	1	56373426	M.01.01_0_41199	42	1	56470813	D.01.02_0_40152	23	2
56370172	D.07.02_1_39700	19	3	56373427	M.01.01_0_41199	42	1	56470814	D.09.02_0_39867	15	1
56370177	D.07.02_1_39700	22	1	56373428	M.01.01_0_41199	42	1	56470815	D.09.02_0_39867	16	1
56370178	C.02.04_1_39212	14	2	56373436	M.01.01_0_41199	53	1	56470987	D.12.01_1_40279	30	1
	D.12.01_1_40279	6	1	56373800	C.01.02_0_39031	18	2	56471036	D.01.02_0_40152	18	1
	D.13.01_0_40355	14	1		C.03.02_0_39268	12	2		D.09.02_0_39867	10	1
56370186	D.07.02_1_39700	14	5	56373840	D.06.01_1_42932	1	1	56473818	D.04.01_1_42845	6	1
56370187	D.11.01_0_40184	5	1	56374430	D.13.01_0_40355	5	1	56473890	D.12.01_1_40279	52	1
56370209	D.01.02_0_40152	11	1	56374460	B.11.01_0_38871	46	1	56474713	D.12.01_1_40279	52	1
56370210	D.01.02_0_40152	11	1	56374556	C.02.04_1_39212	13	2	56474714	D.12.01_1_40279	52	1
56370211	D.01.02_0_40152	11	1	56374557	C.02.04_1_39212	15	2	56475516	D.12.01_1_40279	50	1
56370212	D.01.02_0_40152	11	1	56374574	M.01.01_0_41199	51	1	56475517	D.12.01_1_40279	52	1
56370267	D.02.02_0_39318	28	1	56375008	T.03.02_0_41719	2	4	56475518	D.12.01_1_40279	52	1
56370282	L.01.01_0_40903	22	4	56375146	M.01.01_0_41199	25	1	56475568	D.12.01_1_40279	23	1
	M.01.01_0_41199	32	4	56375147	M.01.01_0_41199	21	1	56475844	D.12.01_1_40279	53	1
56370287	L.01.01_0_40903	24	2	56375436	B.11.01_0_38871	36	1	56477227	C.02.04_1_39212	26	1
	M.01.01_0_41199	34	2	56375571	D.13.01_0_40355	15	1	56478567	D.12.01_1_40279	25	1
56370288	L.01.01_0_40903	17	2	56375954	T.02.02_0_41675	6	4	56570016	C.02.04_1_39212	1.1	2
	M.01.01_0_41199	18	1	56376256	D.11.01_0_40184	9	1		D.07.02_1_39700	17	1
56370539	W.01.03_0_44163	14	4	56378566	D.12.01_1_40279	26	2		L.01.01_0_40903	5	2
	W.01.04_0_45316	13	4	56378616	D.06.01_1_42932	23	1		M.01.01_0_41199	6	2

## SPARE PARTS INSTANCE INDEX

Code	Parts Table	Pos.	Q.ty	Code	Parts Table	Pos.	Q.ty	Code	Parts Table	Pos.	Q.ty
56570125	D.07.02_1_39700	39	2	57376624	B.05.04_0_50716	8	1	58070513	M.02.03_0_41409	54	1
56570284	L.01.01_0_40903	15	1	57376670	B.02.01_1_47161	17/1	1		M.02.04_0_41480	54	1
	M.01.01_0_41199	16	1	57376675	B.03.03_0_50588	6	1	58070690	A.05.02_0_45864	19	1
56570506	M.01.01_0_41199	20	1		B.03.04_0_50621	6	1	58070741	D.07.02_1_39700	37	5
56573661	D.02.02_0_39318	5	1	57376676	B.03.03_0_50588	7	1		D.13.01_0_40355	18	2
56575035	T.02.02_0_41675	1	2		B.03.04_0_50621	7	1	58070790	D.03.02_1_39804	17	3
56577772	T.02.01_0_41647	1	2	57376726	A.01.01_1_48842	2	1		D.15.04_0_40488	5	2
56578610	D.06.01_1_42932	4	1	57376899	B.02.01_1_47161	17/2	1	58071313	E.02.01_0_46767	3	1
57174915	A.05.02_0_45864	1.3	1	57376900	B.03.03_0_50588	27	2	58071322	T.02.01_0_41647	4	2
57275029	B.04.07_0_40076	17	1	57377317	A.04.02_0_45780	8	1	58071755	T.02.01_0_41647	10.1	2
57275031	B.04.07_0_40076	18	1		A.04.04_0_45812	8	1		T.02.02_0_41675	19.1	2
57371900	A.05.02_0_45864	2	1	57377704	B.05.03_0_50689	7	1	58071757	T.02.01_0_41647	11	2
57374490	B.11.01_0_38871	4	2		B.05.04_0_50716	5	1		T.02.02_0_41675	22	2
57374491	B.11.01_0_38871	5	1	57377707	B.05.03_0_50689	8	1	58072074	A.02.02_0_42523	9	1
57374501	B.11.01_0_38871	30	1		B.05.04_0_50716	6	1	58072075	A.02.02_0_42523	10	1
57374506	B.04.07_0_40076	28	1	57379438	B.02.01_1_47161	27	1	58072081	E.02.01_0_46767	4	1
57374507	B.04.07_0_40076	29	1	58025869	M.01.01_0_41199	42	1	58072389	D.12.01_1_40279	39	1
57374522	B.03.03_0_50588	4	1	58048002	A.02.02_0_42523	26	3	58072398	D.12.01_1_40279	47	4
	B.03.04_0_50621	4	1		B.01.01_0_47067	12	1	58072399	D.12.01_1_40279	42	1
57374523	B.03.03_0_50588	5	1	58070071	D.10.01_0_39887	4	1	58072509	B.07.02_0_42592	30	1
	B.03.04_0_50621	5	1	58070164	D.07.02_1_39700	18	3	58072510	B.07.02_0_42592	33	1
57374545	B.11.01_0_38871	25	2	58070168	D.07.02_1_39700	20	3	58072511	B.07.02_0_42592	32	1
57374553	B.08.02_0_38771	21	1	58070169	D.07.02_1_39700	8	3	58072517	B.07.02_0_42592	31	1
57374594	B.04.07_0_40076	3	1	58070198	D.11.01_0_40184	12	1	58072518	B.07.02_0_42592	22/1	1
57374595	B.04.07_0_40076	4	1	58070205	D.11.01_0_40184	17	1	58072574	B.07.02_0_42592	22/2	1
57375195	M.02.03_0_41409	39	1	58070262	D.02.02_0_39318	27	1	58072575	B.07.02_0_42592	23	1
	M.02.04_0_41480	39	1	58070268	D.02.02_0_39318	29	1	58072737	B.07.02_0_42592	28	1
57376621	B.03.03_0_50588	8	1	58070366	D.14.01_0_40378	10	2	58073156	B.07.02_0_42592	27	2
	B.03.04_0_50621	8	1	58070390	B.11.01_0_38871	44	1	58073411	M.01.01_0_41199	43	2
57376622	B.03.03_0_50588	9	1	58070480	T.02.01_0_41647	9.1	2	58073461	D.02.02_0_39318	12.1	1
	B.03.04_0_50621	9	1	58070482	T.02.01_0_41647	10.3	1	58073889	D.12.01_1_40279	51	1
57376623	B.05.03_0_50689	9	1		T.02.02_0_41675	19.3	2	58074092	D.12.01_1_40279	40	1
	B.05.04_0_50716	7	1	58070513	L.02.02_0_40987	38	1	58074220	B.07.02_0_42592	13	1
57376624	B.05.03_0_50689	10	1		L.02.05_0_41145	39	1	58074221	B.07.02_0_42592	12	1



## SPARE PARTS INSTANCE INDEX

Code	Parts Table	Pos.	Q.ty	Code	Parts Table	Pos.	Q.ty	Code	Parts Table	Pos.	Q.ty
58074222	B.07.02_0_42592	14	1	58075160	M.02.03_0_41409	50	1	58077062	E.03.02_0_42668	11	1
58074488	B.11.01_0_38871	38	1		M.02.04_0_41480	50	1	58077132	A.03.01_0_45689	32	1
58074558	D.03.02_1_39804	9	1	58075226	L.02.02_0_40987	41	1		A.03.02_0_45727	32	1
58074734	F.03.04_1_40827	32	2		L.02.05_0_41145	42	2	58077202	T.02.01_0_41647	19	2
58074736	F.04.01_0_46735	27	1		M.02.03_0_41409	56	1	58077205	T.02.01_0_41647	10	2
58074740	F.03.04_1_40827	17	1		M.02.04_0_41480	56	1	58077226	C.02.04_1_39212	25	1
58074777	B.07.02_0_42592	10	1	58075247	L.02.02_0_40987	6	1	58077305	E.03.02_0_42668	16	1
58074786	B.07.02_0_42592	5	1		L.02.05_0_41145	6	1	58077325	T.02.02_0_41675	19	2
58074787	B.07.02_0_42592	6	1		M.02.03_0_41409	6	1	58077413	F.03.04_1_40827	29	1
58074791	B.07.02_0_42592	4	2		M.02.04_0_41480	6	1	58077579	B.07.02_0_42592	3/3	2
58074792	B.07.02_0_42592	1	1	58075248	F.03.04_1_40827	35	1	58077580	B.07.02_0_42592	3/2	2
58074793	B.07.02_0_42592	2	1	58075250	B.07.02_0_42592	19	1	58077581	B.07.02_0_42592	3/1	2
58074831	B.01.01_0_47067	16	1	58075358	L.02.02_0_40987	34	1	58077601	B.08.02_0_38771	7/1	1
58074836	F.03.04_1_40827	11	1		L.02.05_0_41145	35	1		E.03.02_0_42668	1/1	1
58074839	B.07.02_0_42592	15	1	58075603	L.01.01_0_40903	7	1	58077602	B.08.02_0_38771	7/2	1
58074841	B.07.02_0_42592	8	1		M.01.01_0_41199	8	1		E.03.02_0_42668	1/2	1
58074846	B.07.02_0_42592	16	1	58075873	A.03.01_0_45689	30	1	58077615	B.07.02_0_42592	9	1
58074880	B.07.02_0_42592	11	1		A.03.02_0_45727	30	1	58077654	B.07.02_0_42592	24	1
58074891	F.03.04_1_40827	16	1	58075983	T.02.01_0_41647	12	1	58078631	A.02.02_0_42523	8	1
58074895	A.05.02_0_45864	21	1	58075987	T.02.02_0_41675	21	1	58078677	A.03.01_0_45689	29	1
58074904	E.01.01_0_42630	1	1	58076077	B.07.02_0_42592	21	1		A.03.02_0_45727	29	1
58074958	L.02.02_0_40987	40	2	58076333	F.02.01_0_51232	15	1	58079118	C.02.04_1_39212	1.2	1
	L.02.05_0_41145	41	2	58076334	F.02.01_0_51232	16	1	58079392	E.03.02_0_42668	3	1
	M.02.03_0_41409	55	2	58076355	T.02.01_0_41647	9	2	58079393	E.03.02_0_42668	4	1
	M.02.04_0_41480	55	2	58076750	A.04.03_0_45796	8	1	58079394	E.01.01_0_42630	6	1
58075021	B.07.02_0_42592	20	1		A.04.04_0_45812	9	1	58079395	E.01.01_0_42630	5	1
58075022	B.07.02_0_42592	17	1	58076751	A.04.01_0_45765	8	1	58079433	F.03.04_1_40827	15	1
58075080	L.02.02_0_40987	39	2		A.04.02_0_45780	9	1	58079434	F.03.04_1_40827	48	1
	L.02.05_0_41145	40	2	58076752	A.05.02_0_45864	11	3	58079435	F.03.04_1_40827	47	1
58075082	L.02.02_0_40987	47	1	58076753	A.04.01_0_45765	6	1	58079466	B.07.02_0_42592	7	1
	M.02.03_0_41409	62	1		A.04.03_0_45796	6	1	58079755	E.02.01_0_46767	7	1
58075153	B.07.02_0_42592	18	1	58076984V	B.02.01_1_47161	28	1	58092972	B.02.01_1_47161	2	1
58075159	M.02.03_0_41409	27	1	58076987V	B.02.01_1_47161	29	1	58170021	C.03.02_0_39268	4	1
	M.02.04_0_41480	27	1	58077061	E.03.02_0_42668	10	1	58170026	D.15.04_0_40488	30	2

## SPARE PARTS INSTANCE INDEX

Code	Parts Table	Pos.	Q.ty	Code	Parts Table	Pos.	Q.ty	Code	Parts Table	Pos.	Q.ty
58170034	D.02.02_0_39318	30	6	58170703	D.14.01_0_40378	2	6	58172011	M.02.03_0_41409	14	1
58170045	D.14.01_0_40378	1	2	58170968	B.03.03_0_50588	25	1	58172012	I.01.01_0_40883	3	1
58170054	D.07.02_1_39700	7	3	58171000	T.02.02_0_41675	11	2		L.02.02_0_40987	13/1	2
58170070	D.10.01_0_39887	12	3	58171019	D.14.01_0_40378	3	2		L.02.05_0_41145	13/1	2
58170077	C.02.04_1_39212	11	2	58171021	T.02.01_0_41647	4.2	1		L.02.05_0_41145	14	1
58170130	D.04.01_1_42845	23	1		T.02.02_0_41675	12/1	2		M.02.03_0_41409	13/1	1
	D.12.01_1_40279	10	1	58171027	A.04.01_0_45765	1.4	1		M.02.04_0_41480	13/1	1
58170181	W.01.03_0_44163	1.1	1		A.04.02_0_45780	1.4	1		M.02.04_0_41480	14/1	1
58170195	D.11.01_0_40184	6	2		A.04.03_0_45796	1.4	1	58172013	I.01.01_0_40883	4	1
58170238	A.05.02_0_45864	3	1		A.04.04_0_45812	1.4	1		L.02.02_0_40987	13/2	2
58170245	L.01.01_0_40903	21	2	58171028	A.04.01_0_45765	1.3	1		L.02.05_0_41145	13/2	2
	M.01.01_0_41199	31	2		A.04.02_0_45780	1.3	1		M.02.03_0_41409	13/2	1
58170279	D.04.01_1_42845	8	1		A.04.03_0_45796	1.3	1		M.02.04_0_41480	13/2	1
58170291	L.01.01_0_40903	16	2		A.04.04_0_45812	1.3	1		M.02.04_0_41480	14/2	1
	M.01.01_0_41199	17	2	58171069	A.04.02_0_45780	6	1	58172014	I.01.01_0_40883	5	1
58170306	D.02.02_0_39318	20	2		A.04.04_0_45812	6	1		I.01.01_0_40883	11.2	1
58170344	B.08.02_0_38771	19	1	58171139	D.06.01_1_42932	8	2		L.02.02_0_40987	13/3	2
58170345	B.08.02_0_38771	20	1	58171199	A.01.01_1_48842	1.1	1		L.02.05_0_41145	13/3	2
58170376	B.08.02_0_38771	15	2		A.01.02_1_45599	1.1	1		M.02.03_0_41409	13/3	1
58170436	B.02.01_1_47161	3	1		A.01.03_1_45644	1.1	1		M.02.04_0_41480	13/3	1
58170443	D.02.02_0_39318	23	1	58171200	A.01.01_1_48842	1.2	1		M.02.04_0_41480	14/3	1
58170449	T.02.01_0_41647	15	1		A.01.02_1_45599	1.2	1	58172015	L.02.02_0_40987	10	1
	T.02.02_0_41675	25	1		A.01.03_1_45644	1.2	1		L.02.05_0_41145	10	1
58170453	B.08.02_0_38771	7.1	1	58171536	L.01.01_0_40903	21.2	1	58172016	I.01.01_0_40883	12	1
	E.03.02_0_42668	1.1	1		M.01.01_0_41199	31.2	1		L.02.02_0_40987	20	6
58170512	L.02.02_0_40987	35	1	58171537	L.01.01_0_40903	21.1	1		L.02.05_0_41145	21	6
	L.02.05_0_41145	36	1		M.01.01_0_41199	31.1	1		M.02.03_0_41409	20	3
	M.02.03_0_41409	51	1	58171737	F.03.04_1_40827	34.2	1		M.02.04_0_41480	20	3
	M.02.04_0_41480	51	1	58171901	A.05.02_0_45864	22	1	58172017	I.01.01_0_40883	13	1
58170571	E.03.02_0_42668	4.2	1		E.03.02_0_42668	12	4	58172018	I.01.01_0_40883	14	1
58170572	E.03.02_0_42668	4.1	1	58171925	I.01.01_0_40883	10	1	58172105	D.02.02_0_39318	32	5
58170693	F.04.01_0_46735	20/2	1	58172011	I.01.01_0_40883	1	1	58172106	D.02.02_0_39318	31	5
	L.02.02_0_40987	29	1		L.02.02_0_40987	12	2	58172240	I.01.01_0_40883	6	1
	L.02.05_0_41145	30	1		L.02.05_0_41145	12	1		I.01.01_0_40883	11.3	1





## SPARE PARTS INSTANCE INDEX

Code	Parts Table	Pos.	Q.ty	Code	Parts Table	Pos.	Q.ty	Code	Parts Table	Pos.	Q.ty
58172267	B.08.02_0_38771	7.2	1	58173437	B.12.04_0_51054	4	1	58175191	M.02.04_0_41480	32	1
	E.03.02_0_42668	1.2	1	58173505	F.01.03_0_51164	10	1	58175209	C.01.02_0_39031	22	1
58172304	I.01.01_0_40883	7	1	58173664	D.02.02_0_39318	9	1	58175211	M.02.03_0_41409	44/1	1
	L.02.02_0_40987	11	2	58173772	B.07.02_0_42592	25	1		M.02.04_0_41480	44/1	1
	L.02.05_0_41145	11	2	58173773	B.07.02_0_42592	26	1	58175630	W.01.03_0_44163	8.1	1
	M.02.03_0_41409	12	1	58174192	D.07.02_1_39700	1	3	58175676	F.04.01_0_46735	17	1
	M.02.04_0_41480	12	1	58174305	F.03.04_1_40827	34	2	58175677	F.04.01_0_46735	15	1
58172400	D.02.02_0_39318	24	1	58174417	D.03.02_1_39804	37	1	58175700	E.03.02_0_42668	2	1
	D.12.01_1_40279	34	1	58174547	F.03.04_1_40827	22	1	58175769	B.08.02_0_38771	12	1
58172402	D.12.01_1_40279	35	1	58174555	B.11.01_0_38871	9	1	58175770	B.08.02_0_38771	13	1
58172447	D.12.01_1_40279	36	8	58174581	L.01.01_0_40903	11	1	58175773	A.01.01_1_48842	21	1
58172448	D.12.01_1_40279	37	8		M.01.01_0_41199	12	1		A.01.02_1_45599	21	1
58172463	F.04.01_0_46735	7	2	58174608	A.03.01_0_45689	8	2		A.01.03_1_45644	21	1
58172489	I.01.01_0_40883	8	1		A.03.02_0_45727	8	2	58175965	W.01.03_0_44163	1.2	1
	L.02.02_0_40987	15	1	58174644	B.11.01_0_38871	39	2	58175966	W.01.03_0_44163	8.2	1
	L.02.05_0_41145	16	1	58174732	F.04.01_0_46735	25	1	58176271	W.01.04_0_45316	6/1	1
58172707	I.01.01_0_40883	2	1	58174928	B.08.02_0_38771	14	1	58176272	W.01.04_0_45316	6/2	1
58173030	D.03.02_1_39804	5	1	58174974	I.01.01_0_40883	11	1	58176323	W.01.03_0_44163	6.1	1
58173072	T.02.02_0_41675	21.1	1	58175014	F.01.03_0_51164	14	2	58176324	W.01.03_0_44163	6.2	1
58173116	B.08.02_0_38771	19.1	2	58175083	L.02.02_0_40987	49	1	58176336	F.01.03_0_51164	21	1
	B.08.02_0_38771	20.1	2		M.02.03_0_41409	64	1	58176337	F.01.03_0_51164	11	1
58173119	B.08.02_0_38771	19.2	2	58175121	A.01.01_1_48842	33	1	58176396	E.03.02_0_42668	13	2
	B.08.02_0_38771	20.2	2		A.01.02_1_45599	33	1	58176406	E.01.01_0_42630	7	2
58173120	B.08.02_0_38771	19.3	1		A.01.03_1_45644	33	1		E.03.02_0_42668	14	2
58173121	B.08.02_0_38771	20.3	1	58175122	A.04.01_0_45765	1.5	1	58176618	A.01.01_1_48842	30	1
58173195	D.03.02_1_39804	16.1	2		A.04.02_0_45780	1.5	1		A.01.02_1_45599	30	1
	D.03.02_1_39804	28.1	2		A.04.03_0_45796	1.5	1		A.01.03_1_45644	30	1
	D.03.02_1_39804	34.1	4		A.04.04_0_45812	1.5	1	58176755	A.04.01_0_45765	1	1
58173361	I.01.01_0_40883	9	1	58175187	M.02.03_0_41409	45	2		A.04.03_0_45796	1	1
	L.02.02_0_40987	14	1		M.02.04_0_41480	45	2	58176898	A.04.02_0_45780	1	1
	L.02.05_0_41145	15	1	58175188	M.02.03_0_41409	44/2	1		A.04.04_0_45812	1	1
	M.02.03_0_41409	18	1		M.02.04_0_41480	44/2	1	58177182	F.02.01_0_51232	3	1
	M.02.04_0_41480	18	1	58175191	I.01.01_0_40883	15	1	58177274	B.01.01_0_47067	3	1
58173399	F.04.01_0_46735	10	1		M.02.03_0_41409	32	1	58177330	B.05.03_0_50689	25	2



## SPARE PARTS INSTANCE INDEX

Code	Parts Table	Pos.	Q.ty	Code	Parts Table	Pos.	Q.ty	Code	Parts Table	Pos.	Q.ty
58177330	B.05.04_0_50716	20	2	58178960	D.15.04_0_40488	17	1	59073242	D.15.04_0_40488	31	1
58177400	A.01.01_1_48842	27	1	58179010	E.01.01_0_42630	2	2	59073674	B.04.07_0_40076	6	1
	A.01.02_1_45599	27	1	58179413	E.01.01_0_42630	8	2	59073678	B.04.07_0_40076	5	1
	A.01.03_1_45644	27	1	58179414	B.03.03_0_50588	11	2	59073681	A.02.02_0_42523	11/2	1
58177653	D.02.02_0_39318	2	1		B.03.04_0_50621	11	2	59073685	D.03.02_1_39804	22	1
58177722	B.12.03_0_46827	1	1	58179463	F.01.03_0_51164	1	1	59073725	D.03.02_1_39804	16	1
58177732	T.03.03_0_42459	2.1	1		F.02.01_0_51232	1	1	59074081	D.03.02_1_39804	34	1
58177736	T.03.03_0_42459	5	1	58192377	B.12.03_0_46827	3	1	59074206	D.03.02_1_39804	28	1
58177737	T.03.03_0_42459	6	2		B.12.04_0_51054	14	1	59074213	A.02.02_0_42523	15/2	1
58177738	T.03.03_0_42459	7	2	59070012	C.01.02_0_39031	14	1	59074332	F.03.04_1_40827	5	1
58177739	T.03.03_0_42459	8	6	59070051	D.15.04_0_40488	34	1	59074346	A.02.02_0_42523	11/1	1
58177740	T.03.03_0_42459	9	2	59070065	D.01.02_0_40152	22	1	59074347	A.02.02_0_42523	15/1	1
58177741	T.03.03_0_42459	11	1		D.09.02_0_39867	12	1	59074403	B.11.01_0_38871	23	1
58177742	T.03.03_0_42459	12	2	59070094	D.10.01_0_39887	13	1	59074459	D.15.04_0_40488	25	1
58177743	T.03.03_0_42459	14	1	59070289	L.01.01_0_40903	18	1	59074468	B.11.01_0_38871	1	1
58177744	T.03.03_0_42459	15	1		M.01.01_0_41199	28	1	59074476V	B.11.01_0_38871	18	1
58177745	T.03.03_0_42459	18	1	59070290	L.01.01_0_40903	19	1	59074477V	B.11.01_0_38871	21	1
58177746	T.03.03_0_42459	19	1		M.01.01_0_41199	29	1	59074482	F.03.04_1_40827	25	1
58177754	D.03.02_1_39804	4	1	59070333	D.15.04_0_40488	6	1	59074525V	B.11.01_0_38871	34	1
58177761	M.02.03_0_41409	41	1	59070448	T.02.01_0_41647	16	1	59074546	F.03.04_1_40827	23	1
	M.02.04_0_41480	41	1		T.02.02_0_41675	26	1	59074598	B.04.07_0_40076	1	1
58177867	B.08.02_0_38771	11	1	59070591	B.03.03_0_50588	24	1	59074599	B.04.07_0_40076	2	1
58177978	T.02.02_0_41675	12/2	2	59070592	B.05.03_0_50689	17	1	59074623	D.03.02_1_39804	12	1
58178571	W.01.04_0_45316	9/1	1		B.05.04_0_50716	15	1	59074662	B.02.01_1_47161	20	6
58178572	W.01.04_0_45316	9/2	1	59070702	T.03.01_0_41710	1	1	59074744	F.04.01_0_46735	19	1
58178585	A.03.02_0_45727	1	1	59070838	C.02.04_1_39212	16	2	59074748	F.04.01_0_46735	23	1
58178586	A.03.01_0_45689	1	1	59071241	B.12.03_0_46827	13	1	59074749	F.04.01_0_46735	24	1
58178638	A.03.01_0_45689	34	1	59071966	B.05.03_0_50689	24	1	59074754	L.02.02_0_40987	7	1
	A.03.02_0_45727	34	1	59072057	L.02.02_0_40987	19	4		L.02.05_0_41145	7	1
58178646	A.01.02_1_45599	2	1		L.02.05_0_41145	20	4	59074759	L.02.02_0_40987	26	1
	A.01.03_1_45644	2	1		M.02.03_0_41409	19	2		L.02.05_0_41145	27	1
58178811	D.01.02_0_40152	1/2	1		M.02.04_0_41480	19	2	59074993	D.12.01_1_40279	64	1
58178873	D.01.02_0_40152	1/1	1	59073184	A.04.02_0_45780	7	1	59075012	T.03.02_0_41719	1.1	1
58178954	F.03.04_1_40827	1	1		A.04.04_0_45812	7	1	59075037	L.02.02_0_40987	25	1



## SPARE PARTS INSTANCE INDEX

Code	Parts Table	Pos.	Q.ty	Code	Parts Table	Pos.	Q.ty	Code	Parts Table	Pos.	Q.ty
59075037	L.02.05_0_41145	26	1	59076100	T.02.02_0_41675	8	2	59077055	B.03.04_0_50621	15	1
59075039	L.02.02_0_40987	27	1	59076211	F.01.03_0_51164	4	1	59077056	B.03.04_0_50621	16	1
	L.02.05_0_41145	28	1	59076212	F.01.03_0_51164	20	2	59077228	D.15.04_0_40488	1	1
	M.02.03_0_41409	24	1	59076213	F.01.03_0_51164	12	1	59077233	D.15.04_0_40488	29	1
	M.02.04_0_41480	24	1	59076224	F.01.03_0_51164	27	1	59077234	D.15.04_0_40488	27	1
59075137	M.01.01_0_41199	60	1	59076225	F.01.03_0_51164	26	1	59077242	E.03.02_0_42668	17	1
59075140	M.01.01_0_41199	55	1	59076226	F.01.03_0_51164	23	1	59077318	A.01.01_1_48842	12	1
59075148	M.01.01_0_41199	19	1	59076612	B.03.03_0_50588	18	1		A.01.02_1_45599	12	1
59075169	M.02.03_0_41409	7	1	59076614	B.03.03_0_50588	16	1		A.01.03_1_45644	12	1
	M.02.04_0_41480	7	1	59076616	B.03.03_0_50588	15	1	59077359	B.05.03_0_50689	18	1
59075171	M.02.03_0_41409	49	1	59076619	A.01.02_1_45599	32	1	59077445V	B.05.03_0_50689	3	1
	M.02.04_0_41480	49	1		A.01.03_1_45644	32	1		B.05.04_0_50716	1	1
59075178	M.01.01_0_41199	61	1	59076620	A.01.01_1_48842	32	1	59077449V	B.05.03_0_50689	4	1
59075224	F.03.04_1_40827	36	1	59076641V	B.03.03_0_50588	2	1		B.05.04_0_50716	2	1
59075225	F.03.04_1_40827	37	1		B.03.04_0_50621	2	1	59077474	B.05.03_0_50689	20	2
59075254	M.02.03_0_41409	37	1	59076645V	B.03.03_0_50588	1	1		B.05.04_0_50716	17	2
	M.02.04_0_41480	37	1		B.03.04_0_50621	1	1	59077934	A.05.02_0_45864	13	1
59075283	B.01.01_0_47067	28	1	59076679	A.05.02_0_45864	23	1	59077935	A.05.02_0_45864	17	1
59075360	L.02.02_0_40987	32	1	59076682	A.01.02_1_45599	36	1	59078588	L.01.01_0_40903	30	1
	L.02.05_0_41145	33	1		A.01.03_1_45644	36	1	59078595	F.01.03_0_51164	24	1
59075572	D.13.01_0_40355	21	1	59076684	A.03.01_0_45689	13	1	59078865	D.13.01_0_40355	22	1
					A.03.02_0_45727	13	1	59079167	A.01.01_1_48842	6	1
59075678	F.04.01_0_46735	12	1						A.01.02_1_45599	6	1
59075679	F.04.01_0_46735	28	1	59076685	A.05.02_0_45864	12	1		A.01.03_1_45644	6	1
59075716	B.04.07_0_40076	34	1	59076686	A.05.02_0_45864	26	1				
					B.02.01_1_47161	6	1	59079186	T.02.02_0_41675	2	1
59075791	T.02.01_0_41647	5	1					59079187	T.02.02_0_41675	3	1
59075813	C.02.04_1_39212	20	1	59076688	A.01.01_1_48842	16	1				
					A.01.02_1_45599	16	1	59079478	F.02.01_0_51232	12	1
59075840	T.02.01_0_41647	6	1		A.01.03_1_45644	16	1				
59075850	T.02.02_0_41675	13	1					59079479	F.01.03_0_51164	3	1
59075885	T.02.02_0_41675	14	1	59076690	B.03.03_0_50588	19	2	59270304	W.01.03_0_44163	1/1	1
59075917	F.04.01_0_46735	22	1	59076756	B.01.01_0_47067	21	1	59271011	F.04.01_0_46735	8	1
59075979	M.02.03_0_41409	28	1	59076780	B.05.03_0_50689	14	1	59273925	W.01.03_0_44163	1/2	1
	M.02.04_0_41480	28	1		B.05.04_0_50716	12	1	59275632	W.01.03_0_44163	8/1	1
59076085	L.01.01_0_40903	12	1	59076902	B.03.03_0_50588	28	1	59275633	W.01.03_0_44163	8/2	1
	M.01.01_0_41199	13	1	59076903	B.03.03_0_50588	29	1	59276002	C.02.04_1_39212	24	1



## SPARE PARTS INSTANCE INDEX

Code	Parts Table	Pos.	Q.ty	Code	Parts Table	Pos.	Q.ty	Code	Parts Table	Pos.	Q.ty
59276003	C.02.04_1_39212	1	1	59900344	A.01.01_1_48842	1.3	1	59901050	B.12.03_0_46827	2	1
59276076	D.12.01_1_40279	48	1		A.01.02_1_45599	1.3	1	59901086	E.01.01_0_42630	8.1	2
59276320	W.01.03_0_44163	6/1	1		A.01.03_1_45644	1.3	1	59901087	E.03.02_0_42668	13.1	2
59276321	W.01.03_0_44163	6/2	1	59900345	A.01.01_1_48842	1.5	1	F0150010905	W.01.03_0_44163	11	1
59277414	W.01.04_0_45316	1/2	1		A.01.02_1_45599	1.5	1		W.01.04_0_45316	10	1
59277415	W.01.04_0_45316	1/1	1		A.01.03_1_45644	1.5	1	F0150036216	B.12.04_0_51054	2	1
59278554	D.03.02_1_39804	1	1	59900347	A.04.01_0_45765	1.2	1	F0150036219	B.12.04_0_51054	3	1
59278555	D.03.02_1_39804	2	1		A.04.02_0_45780	1.2	1	F0190018909	E.02.01_0_46767	2	1
59375009	T.03.02_0_41719	1	1		A.04.03_0_45796	1.2	1	F0256808000	A.05.02_0_45864	31	1
59376519	D.01.02_0_40152	12	1		A.04.04_0_45812	1.2	1		B.03.03_0_50588	30	1
59377433	D.12.01_1_40279	57	1	59900353	A.04.01_0_45765	1.1	1		B.04.07_0_40076	27	1
59377730	T.03.03_0_42459	2	1		A.04.02_0_45780	1.1	1	F0256809010	B.11.01_0_38871	3	1
59377734	T.03.03_0_42459	1	1		A.04.03_0_45796	1.1	1	F0256809050	A.03.01_0_45689	6	1
59378814	D.09.02_0_39867	4	1		A.04.04_0_45812	1.1	1		A.03.02_0_45727	6	1
59900152	B.12.03_0_46827	15	1	59900361	W.01.03_0_44163	1.3	1	F0256909000	F.03.04_1_40827	53	1
59900153	B.12.03_0_46827	9	1		W.01.03_0_44163	6.3	1	F0256910000	B.03.03_0_50588	31	1
59900154	B.12.03_0_46827	8	4		W.01.03_0_44163	8.3	1	F0256910010	B.05.03_0_50689	11	1
59900155	B.12.03_0_46827	7/1	1	59900376	D.12.01_1_40279	12	1		B.05.04_0_50716	9	1
59900156	B.12.03_0_46827	6	1	59900766	A.01.01_1_48842	1.4	1	F0801022000	T.03.03_0_42459	16	1
59900157	B.12.03_0_46827	10	1		A.01.02_1_45599	1.4	1	F0801028000	T.03.03_0_42459	10	6
59900158	B.12.03_0_46827	10	18		A.01.03_1_45644	1.4	1	F0801050000	M.01.01_0_41199	23	1
59900159	B.12.03_0_46827	5	1	59900975	B.02.01_1_47161	1/1	1	F0801095000	D.15.04_0_40488	24	1
59900160	B.12.03_0_46827	12	1	59900976	B.02.01_1_47161	1/3	1	F0801163000	F.03.04_1_40827	31	1
59900161	B.12.03_0_46827	14	1	59900977	B.02.01_1_47161	1/5	1	F0801241010	D.05.01_1_42883	4	4
59900183	B.12.04_0_51054	5	1	59900978	B.02.01_1_47161	1/7	1		D.12.01_1_40279	15	1
59900184	B.12.04_0_51054	6	1	59900979	B.02.01_1_47161	1/9	1		D.15.04_0_40488	4	2
59900185	B.12.04_0_51054	7	1	59900980	B.02.01_1_47161	1/11	1		L.01.01_0_40903	23	2
59900186	B.12.04_0_51054	8	1	59900981	B.02.01_1_47161	1/2	1		M.01.01_0_41199	33	2
59900187	B.12.04_0_51054	9	1	59900982	B.02.01_1_47161	1/4	1	F0801248000	D.12.01_1_40279	12.3	1
59900199	B.12.04_0_51054	1	1	59900983	B.02.01_1_47161	1/6	1	F0801264050	D.02.02_0_39318	14	1
59900230	I.01.01_0_40883	10.1	1	59900984	B.02.01_1_47161	1/8	1		D.04.01_1_42845	1	1
	I.01.01_0_40883	11.1	1	59900985	B.02.01_1_47161	1/10	1	F0801266100	D.02.02_0_39318	22	1
59900242	E.03.02_0_42668	1.3	1	59900986	B.02.01_1_47161	1/12	1	F0801282000	L.02.02_0_40987	44	12
59900340	F.03.04_1_40827	34.1	1	59901049	B.12.03_0_46827	4	1		L.02.05_0_41145	45	12



## SPARE PARTS INSTANCE INDEX

Code	Parts Table	Pos.	Q.ty	Code	Parts Table	Pos.	Q.ty	Code	Parts Table	Pos.	Q.ty
F0801282000	M.02.03_0_41409	59	8	F0810510000	D.15.04_0_40488	12	4	F0814569000	D.03.02_1_39804	19	2
	M.02.04_0_41480	59	6	F0810527000	D.03.02_1_39804	32	2		M.01.01_0_41199	24	5
F0801282050	D.12.01_1_40279	45	1	F0812523050	D.02.02_0_39318	1	1	F0814585000	B.02.01_1_47161	5	3
F0801297050	D.12.01_1_40279	49	1	F0812599086	D.12.01_1_40279	12.1	1		B.11.01_0_38871	8	1
F0801299100	D.06.01_1_42932	21	2	F0812637000	D.12.01_1_40279	2	2	F0814627000	D.15.04_0_40488	16	1
F0801310600	C.01.02_0_39031	21	1	F0812660020	D.04.01_1_42845	21	1	F0814632000	A.03.01_0_45689	10	4
F0801331050	L.01.01_0_40903	20	2	F0812689050	D.12.01_1_40279	12.2	1		A.03.02_0_45727	10	4
	M.01.01_0_41199	30	2	F0812692015	D.06.01_1_42932	16	1		C.01.02_0_39031	10	2
F0801331150	D.04.01_1_42845	7	2	F0812708030	D.05.01_1_42883	2	1	F0814750010	C.03.02_0_39268	9	16
F0801353000	D.04.01_1_42845	12	1	F0812736010	D.12.01_1_40279	31	1	F0814794000	B.03.03_0_50588	23	2
	D.12.01_1_40279	9	1	F0812783000	D.04.01_1_42845	19	1	F0817500200	A.01.01_1_48842	29	1
F0801380100	D.04.01_1_42845	16	2	F0812784000	D.12.01_1_40279	18	2		A.01.02_1_45599	29	1
F0801422010	D.01.02_0_40152	10	2	F0812811000	D.06.01_1_42932	20	2		A.01.03_1_45644	29	1
F0801455100	D.02.02_0_39318	34	1	F0812838000	C.02.04_1_39212	12	2		A.03.01_0_45689	31	4
F0802104000	D.09.02_0_39867	1	1	F0812859000	D.01.02_0_40152	9	2		A.03.02_0_45727	31	4
F0802163010	D.02.02_0_39318	13	1	F0812868000	D.04.01_1_42845	2	1		A.05.02_0_45864	20	4
F0802228005	D.12.01_1_40279	29	1	F0812868100	D.02.02_0_39318	17	1	F0817500400	A.01.01_1_48842	28	3
F0802239045	D.01.02_0_40152	7	1	F0812878040	D.04.01_1_42845	4	2		A.01.02_1_45599	28	3
F0802700150	D.10.01_0_39887	1	1	F0812899000	D.06.01_1_42932	2	1		A.01.03_1_45644	28	3
F0803050000	F.03.04_1_40827	24	1	F0812918010	D.04.01_1_42845	22	1		A.03.01_0_45689	33	2
F0803057000	D.03.02_1_39804	15	2		D.12.01_1_40279	27	3		A.03.02_0_45727	33	2
F0803078100	D.01.02_0_40152	5	1	F0812951070	D.06.01_1_42932	5	2	F0817500470	A.03.01_0_45689	25	2
F0803185000	L.02.02_0_40987	2	1	F0812951200	D.04.01_1_42845	15	2		A.03.02_0_45727	25	2
	L.02.05_0_41145	2	1	F0812951300	D.12.01_1_40279	21	1	F0817500500	A.03.01_0_45689	22	1
	M.02.03_0_41409	2	1	F0812956000	D.01.02_0_40152	14	2		A.03.02_0_45727	22	1
	M.02.04_0_41480	2	1		D.09.02_0_39867	13	2	F0817500700	A.03.01_0_45689	24	1
F0803199010	D.12.01_1_40279	66	1	F0812957000	D.06.01_1_42932	14	1		A.03.02_0_45727	24	1
F0803209000	D.11.01_0_40184	4	1	F0812957010	D.12.01_1_40279	11	1	F0817500800	A.04.03_0_45796	9	1
F0803209070	C.01.02_0_39031	13	1	F0812975250	D.10.01_0_39887	2	2		A.04.04_0_45812	10	1
F0803259000	C.01.02_0_39031	12	1	F0814545000	A.03.01_0_45689	20	2	F0817500900	A.04.03_0_45796	10	1
F0808060100	T.03.01_0_41710	2	1		A.03.02_0_45727	20	2		A.04.04_0_45812	11	1
F0808518050	B.07.02_0_42592	29	4	F0814547000	B.02.01_1_47161	26	8	F0817501000	A.04.01_0_45765	9	2
F0810510000	D.03.02_1_39804	24	2		C.02.04_1_39212	31	4		A.04.02_0_45780	10	2
	D.14.01_0_40378	6	2	F0814569000	B.01.01_0_47067	20	1	F0817501200	A.04.01_0_45765	7	1



## SPARE PARTS INSTANCE INDEX

Code	Parts Table	Pos.	Q.ty	Code	Parts Table	Pos.	Q.ty	Code	Parts Table	Pos.	Q.ty
F0817501200	A.04.03_0_45796	7	1	F0825403050	B.08.02_0_38771	18	1	F0835037000	L.02.05_0_41145	43	6
F0817503000	F.01.03_0_51164	9	12	F0825414000	A.05.02_0_45864	25	2		M.02.03_0_41409	57	3
F0817640003	D.07.02_1_39700	5	3	F0825417000	E.02.01_0_46767	8	1		M.02.04_0_41480	57	3
F0822537050	D.03.02_1_39804	29	1	F0825436000	B.08.02_0_38771	7.3	1	F0835040030	F.03.04_1_40827	18	2
	D.15.04_0_40488	2	2		E.03.02_0_42668	1.5	1	F0835523000	D.03.02_1_39804	26	1
F0824022000	L.02.02_0_40987	5	1	F0825436003	B.08.02_0_38771	7.4	1	F0837521000	B.11.01_0_38871	43	1
	L.02.05_0_41145	5	1		E.03.02_0_42668	1.6	1	F0837534010	L.02.02_0_40987	18	4
	M.02.03_0_41409	5	1	F0825438000	E.03.02_0_42668	5	1		L.02.05_0_41145	19	4
	M.02.04_0_41480	5	1	F0825480100	E.02.01_0_46767	1	1		M.02.03_0_41409	17	2
F0824110000	F.03.04_1_40827	52	2	F0825488000	E.03.02_0_42668	9	2		M.02.04_0_41480	17	2
	F.04.01_0_46735	21	2	F0825493000	E.03.02_0_42668	18	1	F0838154010	D.12.01_1_40279	59	2
	L.02.02_0_40987	30	23	F0825500220	B.08.02_0_38771	8.1	1	F0838475000	C.01.02_0_39031	9	2
	L.02.05_0_41145	31	24	F0825718020	F.01.03_0_51164	14.1	2	F0842512000	F.03.04_1_40827	12	2
	M.02.03_0_41409	11	15	F0825809000	L.02.02_0_40987	1	1	F0843107000	F.03.04_1_40827	49	1
	M.02.04_0_41480	11	15		L.02.05_0_41145	1	1		F.04.01_0_46735	13	8
F0824113000	C.03.02_0_39268	15	1		M.02.03_0_41409	1	1	F0843109000	F.03.04_1_40827	45	2
	F.02.01_0_51232	14	2		M.02.04_0_41480	1	1	F0843109020	F.03.04_1_40827	51	1
	F.03.04_1_40827	42	2	F0825980030	L.02.02_0_40987	45	6		F.04.01_0_46735	20/1	1
	L.02.02_0_40987	37	4		L.02.05_0_41145	46	6		L.02.02_0_40987	28	7
	L.02.05_0_41145	38	4		M.02.03_0_41409	60	4		L.02.05_0_41145	29	7
	M.02.03_0_41409	53	4		M.02.04_0_41480	60	3		M.02.03_0_41409	10	4
	M.02.04_0_41480	53	4	F0826039000	D.03.02_1_39804	31	2		M.02.04_0_41480	10	4
F0824141000	F.03.04_1_40827	14	8	F0826056000	C.02.04_1_39212	7	2	F0843110010	F.03.04_1_40827	41	1
	L.02.02_0_40987	43	5		L.01.01_0_40903	6	1		L.02.02_0_40987	36	2
	L.02.05_0_41145	44	6		M.01.01_0_41199	7	3		L.02.05_0_41145	37	2
	M.02.03_0_41409	31	4		T.02.02_0_41675	4	2		M.02.03_0_41409	25	1
	M.02.03_0_41409	58	5		T.03.02_0_41719	1.2	1		M.02.03_0_41409	52	2
	M.02.04_0_41480	31	4	F0828029070	A.02.02_0_42523	1	1		M.02.04_0_41480	25	1
	M.02.04_0_41480	58	3	F0828468050	D.13.01_0_40355	12	2		M.02.04_0_41480	52	2
F0824185000	F.01.03_0_51164	22	1	F0831047000	D.13.01_0_40355	9	1	F0843116000	F.03.04_1_40827	13	4
	F.04.01_0_46735	16	1	F0831065000	B.01.01_0_47067	13	1		L.02.02_0_40987	48	1
F0825115010	B.08.02_0_38771	10	1	F0831125000	A.02.02_0_42523	14	2		M.02.03_0_41409	30	2
F0825139000	E.03.02_0_42668	1.4	1	F0835031010	F.03.04_1_40827	19	4		M.02.03_0_41409	63	1
F0825400060	B.08.02_0_38771	9	1	F0835037000	L.02.02_0_40987	42	5		M.02.04_0_41480	30	2

## SPARE PARTS INSTANCE INDEX

Code	Parts Table	Pos.	Q.ty	Code	Parts Table	Pos.	Q.ty	Code	Parts Table	Pos.	Q.ty
F0843561000	A.02.02_0_42523	24	1	F0843643060	F.01.03_0_51164	17	14	F0843841000	F.04.01_0_46735	11	1
F0843570000	A.01.01_1_48842	24	2		F.03.04_1_40827	27	2	F0843843060	T.02.01_0_41647	8	4
	A.01.02_1_45599	24	2		F.04.01_0_46735	3	2		T.02.02_0_41675	16	4
	A.01.03_1_45644	24	2		L.01.01_0_40903	10	2	F0843907000	D.03.02_1_39804	8	2
	A.03.01_0_45689	3	6		L.01.01_0_40903	26	2		F.01.03_0_51164	8	1
	A.03.02_0_45727	3	6		L.02.02_0_40987	9	13		F.03.04_1_40827	20	4
	A.05.02_0_45864	28	2		L.02.05_0_41145	9	13		F.03.04_1_40827	50	2
	B.01.01_0_47067	23	12		M.01.01_0_41199	11	2		F.04.01_0_46735	14	16
	B.02.01_1_47161	15	2		M.01.01_0_41199	36	2	F0843921030	B.01.01_0_47067	26	2
	B.04.07_0_40076	20	4		M.02.03_0_41409	9	14	F0843948000	F.03.04_1_40827	33	4
	C.01.02_0_39031	26	8		M.02.04_0_41480	9	14		F.04.01_0_46735	9	1
	F.02.01_0_51232	7	4		T.02.01_0_41647	14	2	F0843993060	W.01.03_0_44163	17	4
	F.03.04_1_40827	8	2		T.02.02_0_41675	24	2		W.01.04_0_45316	16	4
	F.03.04_1_40827	39	1	F0843696000	B.12.04_0_51054	12	6	F0844030070	A.01.01_1_48842	22	1
	F.04.01_0_46735	6	3	F0843711000	D.15.04_0_40488	35	4		A.01.02_1_45599	22	1
	M.01.01_0_41199	57	2	F0843755000	A.01.01_1_48842	11	6		A.01.03_1_45644	22	1
	M.01.01_0_41199	63	1		A.01.02_1_45599	11	6	F0844084000	W.01.04_0_45316	1.4	5
F0843581010	D.03.02_1_39804	7	2		A.01.03_1_45644	11	6	F0844150000	W.01.03_0_44163	3	4
F0843641000	D.03.02_1_39804	10	1		A.03.01_0_45689	9	5		W.01.04_0_45316	3	4
	D.12.01_1_40279	63	1		A.03.02_0_45727	9	5	F0844240000	C.02.04_1_39212	19	2
F0843643060	A.01.01_1_48842	4	7		A.05.02_0_45864	15	2	F0844273090	C.01.02_0_39031	5	2
	A.01.02_1_45599	4	7		B.04.07_0_40076	9	7		C.03.02_0_39268	5	1
	A.01.03_1_45644	4	7		C.01.02_0_39031	11	12		D.10.01_0_39887	16	1
	A.02.02_0_42523	5	5		E.02.01_0_46767	6	1		L.02.02_0_40987	50	1
	A.03.01_0_45689	17	3		F.01.03_0_51164	19	4		L.02.05_0_41145	49	1
	A.03.02_0_45727	17	3		F.02.01_0_51232	10	2		M.02.03_0_41409	65	1
	A.05.02_0_45864	30	1		F.03.04_1_40827	4	6		M.02.04_0_41480	63	1
	B.01.01_0_47067	19	1		M.01.01_0_41199	48	2	F0847434000	D.07.02_1_39700	38	5
	B.02.01_1_47161	9	6		T.02.02_0_41675	18	2		D.13.01_0_40355	19	2
	B.04.07_0_40076	26	14	F0843771000	D.07.02_1_39700	15	5	F0847462000	D.13.01_0_40355	8	1
	B.11.01_0_38871	15	16		F.04.01_0_46735	18	3	F0848655000	W.01.03_0_44163	10	1
	C.02.04_1_39212	18	2	F0843815000	F.02.01_0_51232	11	2	F0848655100	W.01.03_0_44163	13	1
	C.02.04_1_39212	23	2	F0843818000	B.04.07_0_40076	11	6	F0848664000	W.01.03_0_44163	5	1
	D.15.04_0_40488	22	7	F0843841000	D.03.02_1_39804	3	2	F0848672100	W.01.04_0_45316	8	1

## SPARE PARTS INSTANCE INDEX

Code	Parts Table	Pos.	Q.ty	Code	Parts Table	Pos.	Q.ty	Code	Parts Table	Pos.	Q.ty
F0848676050	W.01.03_0_44163	7	1	F0852538050	F.01.03_0_51164	7	1	F0862464050	A.05.02_0_45864	24	2
F0848679600	W.01.03_0_44163	12	1	F0852550010	L.02.02_0_40987	46/1	2	F0862478070	D.10.01_0_39887	8	3
F0848681600	W.01.04_0_45316	11	1		L.02.05_0_41145	47/1	2	F0862479020	B.08.02_0_38771	16	4
F0848681605	W.01.04_0_45316	12	1	F0852550020	L.02.02_0_40987	46/2	2		B.11.01_0_38871	21	8
F0848844000	W.01.04_0_45316	7	1		L.02.05_0_41145	47/2	2	F0862479034	B.04.07_0_40076	31	1
F0848855000	W.01.03_0_44163	9	1		M.02.03_0_41409	61/1	2	F0862479035	A.01.01_1_48842	5	1
F0848920000	W.01.03_0_44163	4	1		M.02.04_0_41480	61/1	2		A.01.02_1_45599	5	1
	W.01.04_0_45316	4	1	F0852550030	L.02.02_0_40987	46/3	1		A.01.03_1_45644	5	1
F0849206005	A.03.01_0_45689	19	1		L.02.05_0_41145	47/3	2		B.04.07_0_40076	19	4
	A.03.02_0_45727	19	1		M.02.03_0_41409	61/2	1		B.04.07_0_40076	30	3
F0849500001	A.05.02_0_45864	1.1	1		M.02.04_0_41480	61/2	1	F0862481000	A.05.02_0_45864	18	2
F0849500002	A.05.02_0_45864	1.2	1	F0852550040	L.02.02_0_40987	46/4	1		M.02.03_0_41409	35	1
F0850100000	D.05.01_1_42883	1	1		M.02.03_0_41409	61/3	1		M.02.04_0_41480	35	1
F0850100010	D.05.01_1_42883	1	1	F0852578060	D.07.02_1_39700	41	1	F0862495010	B.12.04_0_51054	11	4
F0850100020	D.05.01_1_42883	1	1		D.12.01_1_40279	48.1	2	F0862593050	M.01.01_0_41199	52	1
F0851044000	D.01.02_0_40152	24	3	F0858520000	A.02.02_0_42523	7	1	F0862655000	D.10.01_0_39887	14	4
F0851156000	D.07.02_1_39700	33	4	F0860058010	D.03.02_1_39804	35	1	F0862657000	D.02.02_0_39318	10	1
F0851180000	D.13.01_0_40355	16	2	F0860058020	D.03.02_1_39804	36	1	F0862694000	A.01.02_1_45599	3	3
F0851226000	D.12.01_1_40279	58	1	F0860091020	D.15.04_0_40488	32	1		A.01.03_1_45644	3	3
F0851260000	D.11.01_0_40184	16	1	F0861867001	B.08.02_0_38771	22	3		D.03.02_1_39804	18	1
F0851262000	D.07.02_1_39700	34	4	F0861867050	A.05.02_0_45864	4	6	F0862785000	D.01.02_0_40152	2/1	1
F0851267050	D.07.02_1_39700	35	3	F0861928050	B.11.01_0_38871	31	4	F0862796000	F.01.03_0_51164	5	4
	D.11.01_0_40184	11	1	F0861941000	E.03.02_0_42668	6	3	F0862875000	B.11.01_0_38871	6	1
F0851486000	L.01.01_0_40903	31	1	F0861973000	M.02.03_0_41409	40	4	F0862944000	D.07.02_1_39700	13	1
	M.01.01_0_41199	54	1		M.02.04_0_41480	40	4	F0863183000	D.07.02_1_39700	40	1
	T.02.01_0_41647	10.2	3	F0862129000	F.03.04_1_40827	44	2	F0863208050	M.01.01_0_41199	46	1
	T.02.02_0_41675	7	4	F0862345000	D.03.02_1_39804	6	2	F0863267050	C.02.04_1_39212	6	8
	T.02.02_0_41675	19.2	4		F.04.01_0_46735	5	2	F0863302000	T.02.02_0_41675	9	2
	T.03.01_0_41710	5	4	F0862448100	D.03.02_1_39804	11	1	F0863311250	D.01.02_0_40152	13	8
	T.03.02_0_41719	3	4		D.12.01_1_40279	62	1		D.09.02_0_39867	5	8
F0851497000	B.01.01_0_47067	29	1	F0862462010	L.02.02_0_40987	4	1	F0863429000	L.01.01_0_40903	4	4
	T.03.01_0_41710	3	1		L.02.05_0_41145	4	1		M.01.01_0_41199	4	4
F0852107050	T.02.01_0_41647	4.1	1		M.02.03_0_41409	4	1	F0863586000	B.11.01_0_38871	29	6
F0852516020	B.11.01_0_38871	19	1		M.02.04_0_41480	4	1	F0863672010	T.03.03_0_42459	13	1





## SPARE PARTS INSTANCE INDEX

Code	Parts Table	Pos.	Q.ty
F0863890010	C.01.02_0_39031	19	16
	C.03.02_0_39268	13	16
F0863925000	C.02.04_1_39212	2	7
F0863951000	C.02.04_1_39212	4	1
F0863997010	C.02.04_1_39212	3	1
F0864180000	T.03.01_0_41710	8	8
	T.03.02_0_41719	6	8
F0864222010	C.01.02_0_39031	17	16
	T.03.03_0_42459	3	8
F0864314000	W.01.03_0_44163	16	4
	W.01.04_0_45316	15	4
F0864335020	A.01.01_1_48842	19	1
	A.01.02_1_45599	19	1
	A.01.03_1_45644	19	1
F0864357100	W.01.04_0_45316	1.3	5
F0864377000	B.03.03_0_50588	22	2
F0864410500	W.01.03_0_44163	2	4
	W.01.04_0_45316	2	4
F0865040000	B.08.02_0_38771	1	1
F0865040020	B.08.02_0_38771	2	1
F0865474000	B.08.02_0_38771	3	1
F0865474005	B.08.02_0_38771	3.1	1
F0907170150	B.07.02_0_42592	34	1
P000000260007	B.02.01_1_47161	13	1
P227332000000	F.03.04_1_40827	21	1
P236220000000	A.03.01_0_45689	28	1
	A.03.02_0_45727	28	1
P236340000000	A.03.01_0_45689	26	1
	A.03.02_0_45727	26	1
P241171000000	L.02.02_0_40987	33	1
	L.02.05_0_41145	34	1
P254124000000	F.04.01_0_46735	30	2
P439149000000	B.03.03_0_50588	21	2
P470330000000	D.12.01_1_40279	14	1

Code	Parts Table	Pos.	Q.ty
P470433000000	D.12.01_1_40279	13	1
P917280000000	B.03.03_0_50588	20	2